

Earth of the Slumbering and Liquid Trees

Benjamin Tassie | 2023

For Sampled Historical Organs, MIDI Keyboards, and ROLI Seaboard Rise 2 Keyboard

For Zubin Kanga

Duration: c.72 minutes

Commissioned by Dr Zubin Kanga as part of Royal Holloway, University of London's UKRI Future Leaders Fellowship funded research project, Cyborg Soloists.

This piece requires two 88-key MIDI keyboards (with sustain pedals), one ROLI Seaboard Rise 2 MPE Keyboard, and a laptop running Ableton Live 11. The live set is available from the composer. The technical set-up should be as per the diagram, below. Please note: the performer and loudspeakers are to be in the middle of the performance space, with the audience seated around them. The ROLI Seaboard Rise 2 keyboard should be pre-set so that pitch-bend is turned off, with care taken to ensure that it is in the correct octave. All movements are to be played *attacca*. In 'Part Three' the ROLI Keyboard's 'push' functionality is mapped to the sampler instrument's LFO rate; slide is mapped to the filter frequency cut-off. Expressive use of these parameters is left to the performer's discretion. In 'Part Two' the MIDI keyboards both use a nineteen-note per octave scale; as such, their music is transposing.

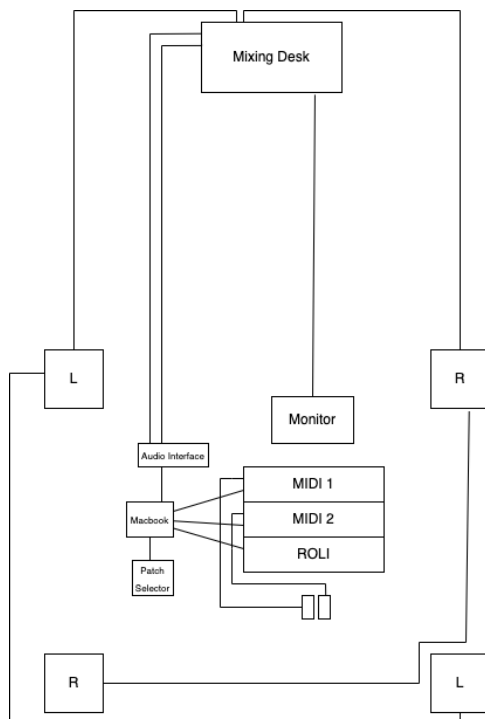

Earth of the Slumbering and Liquid Trees

for Zubin Kanga

Benjamin Tassie

♩ = 60

Pre-set: Patch 1

Part One: Earth

Thomas Parker Enharmonic Organ

MIDI 1

MIDI 1 staff for Thomas Parker Enharmonic Organ. The staff is in 4/4 time with a key signature of three flats. It contains a single quarter note in the right hand on the first beat of the first measure, followed by rests. The left hand contains rests throughout.

ped.

Van Straten Organ (Hoofdwerk) & Pedals

MIDI 2

MIDI 2 staff for Van Straten Organ (Hoofdwerk) & Pedals. The staff is in 4/4 time with a key signature of three flats. It contains a whole note chord in the right hand on the first beat of the first measure, followed by rests. The left hand contains rests throughout.

ped.

8va

1680 Chamber Organ & Novation Peak Synthesiser (re-sampled)

ROLI

ROLI staff for 1680 Chamber Organ & Novation Peak Synthesiser (re-sampled). The staff is in 4/4 time with a key signature of three flats. It contains rests throughout.



MIDI 1

MIDI 1 staff for Part 2. The staff is in 4/4 time with a key signature of three flats. It contains a quarter note in the right hand on the first beat of the first measure, followed by rests. The left hand contains rests throughout.

(ped.)

A

V.S.

MIDI 2

MIDI 2 staff for Part 2. The staff is in 4/4 time with a key signature of three flats. It contains a quarter note in the right hand on the first beat of the first measure, followed by rests. The left hand contains rests throughout.

(ped.)

19

MIDI 1

MIDI 2

(Ped.)

(Ped.)



29

MIDI 1

MIDI 2

B

(Ped.)

(Ped.)



38

MIDI 1

MIDI 2

(Ped.)

(Ped.)

C

48

MIDI 1

MIDI 2

(Ped.)

(Ped.)

Double bar line

57

MIDI 1

MIDI 2

(Ped.)

(Ped.)

MIDI 1

MIDI 2

67

D

(Red.)

(Red.)



MIDI 1

MIDI 2

76

E

(Red.)

(Red.)



MIDI 1

MIDI 2

86

F

L.H.

(Red.)

(Red.)

96

MIDI 1

MIDI 2

(Red.)

(Red.)

G

106

MIDI 1

MIDI 2

(Red.)

(Red.)

G

115

MIDI 1

MIDI 2

(Red.)

(Red.)

H

125 I

MIDI 1

MIDI 2

(Lento.)

1

(Lento.)

(Lento.)



133 J

MIDI 1

MIDI 2

(Lento.)

(Lento.)



142 V.S.

MIDI 1

MIDI 2

(Lento.)

(Lento.)

K

150

MIDI 1

MIDI 2

(Red.)

(Red.)

Red.



159

MIDI 1

MIDI 2

(Red.)

Red.

(Red.)



169

MIDI 1

MIDI 2

(Red.)

(Red.)

L

179

MIDI 1

MIDI 2

(Ped.)

(Ped.)



189

MIDI 1

MIDI 2

(Ped.)

(Ped.)



M

199

MIDI 1

MIDI 2

(Ped.)

(Ped.)

N

208

MIDI 1

MIDI 1 piano part for measures 208-217. The right hand contains whole rests, and the left hand contains whole rests. A fermata is placed over the left hand part starting at measure 210.

(Ped.)

MIDI 2

MIDI 2 piano part for measures 208-217. The right hand contains whole rests, and the left hand contains whole rests. A fermata is placed over the left hand part starting at measure 210.

(Ped.)

ROLI

ROLI piano part for measures 208-217. The right hand contains whole rests, and the left hand contains whole rests. A fermata is placed over the left hand part starting at measure 210.



218

MIDI 1

MIDI 1 piano part for measures 218-227. The right hand contains whole rests, and the left hand contains whole rests. A fermata is placed over the left hand part starting at measure 220.

(Ped.)

MIDI 2

MIDI 2 piano part for measures 218-227. The right hand contains whole rests, and the left hand contains whole rests. A fermata is placed over the left hand part starting at measure 220.

(Ped.)

ROLI

ROLI piano part for measures 218-227. The right hand contains whole rests, and the left hand contains whole rests. A fermata is placed over the left hand part starting at measure 220.

228

O

MIDI 1

MIDI 2

ROLI



238

V.S.

MIDI 1

MIDI 2

ROLI

247

P Q

MIDI 1

MIDI 2

ROLI

(Ped.)

(Ped.)



257

V.S.

MIDI 1

MIDI 2

ROLI

(Ped.)

(Ped.)

R.H.

R

262

MIDI 1

MIDI 2

ROLI

(Ped.)

R.H.



S

272

MIDI 1

MIDI 2

ROLI

(Ped.)

T

281

MIDI 1

MIDI 2

ROLI

(Ped.)

(Ped.)

Double bar line symbol

U

291

MIDI 1

MIDI 2

ROLI

(Ped.)

(Ped.)

300

MIDI 1

MIDI 2

ROLI

(Ped.)

(Ped.)



310

V

MIDI 1

MIDI 2

ROLI

(Ped.)

(Ped.)

W

318

MIDI 1

MIDI 2

ROLI

(Ped.)

(Ped.)



324

MIDI 1

MIDI 2

ROLI

V.S.

(Ped.)

(Ped.)

331 X

MIDI 1

MIDI 2

ROLI

(Red.)

R.H.

(Red.)

(Red.)



341 Y v.s.

MIDI 1

MIDI 2

ROLI

(Red.)

(Red.)

Z

346

MIDI 1

MIDI 2

ROLI

(*And.*)

R.H.

(*And.*)

Double bar line symbol

V.S.

355

MIDI 1

MIDI 2

ROLI

(*And.*)

(*And.*)

362 AA

MIDI 1

ROLI



371 BB

MIDI 1

MIDI 2

ROLI

381

MIDI 1

MIDI 2

ROLI

(Ped.)

(Ped.)



390

MIDI 1

MIDI 2

ROLI

CC

(Ped.)

(Ped.)

DD

399

MIDI 1

MIDI 2

ROLI



409

MIDI 1

MIDI 2

ROLI

EE

Trigger: Patch 2

418

MIDI 1

MIDI 1 staff with treble and bass clefs, mostly empty with some rests.

(Ped.)

MIDI 2

MIDI 2 staff with treble and bass clefs, mostly empty with some rests.

(Ped.)

Ped.

ROLI

ROLI staff with treble and bass clefs, featuring a melodic line in the bass clef.



FF

Part Two: Air

429

MIDI 1

MIDI 1 staff with treble and bass clefs, mostly empty with some rests.

(Ped.)

Van Straten Organ (Doof), microtonal
Not sounding pitch

MIDI 2

MIDI 2 staff with treble and bass clefs, featuring a melodic line in the treble clef.

ROLI

ROLI staff with treble and bass clefs, featuring a melodic line in the bass clef.

439

GG

MIDI 1

(Ped.)

MIDI 2



449

V.S.
Continue holding
MIDI 1 pedal

MIDI 1

Ped.

MIDI 2

456 **HH** Continue holding MIDI 1 pedal

MIDI 2

466 **II**

475

485

494 **JJ**

504 **KK**

MIDI 1

(Ped.)

513 **LL**

Trigger: Patch 3

MIDI 2

522

2

MIDI 2

531

MM

MIDI 2

541

NN

ed.

MIDI 2

550

ed.

8ba

MIDI 2

560

OO

ed.

MIDI 2

569

V.S.

ed.

PP

QQ

MIDI 2

578

(Red.)



RR

Thomas Parker Enharmonic Organ, microtonal
Not sounding pitch

MIDI 1

588

(Red.)



SS

MIDI 1

598

(Red.)



TT

MIDI 1

608

(Red.)

617 UU

MIDI 1

MIDI 2

Ped.

(Ped.)



627 VV

MIDI 1

MIDI 2

(Ped.)

(Ped.)



637 V.S.

MIDI 1

MIDI 2

(Ped.)

(Ped.)

647 WW

MIDI 1

MIDI 2

(Led.)

(Led.)

Detailed description: This system covers measures 647 to 656. MIDI 1 consists of two staves (treble and bass clef) with rests in the treble and eighth notes in the bass. MIDI 2 also has two staves; the treble staff contains a complex melodic line with many beamed eighth notes and slurs, while the bass staff has rests. A box labeled 'WW' is positioned above measure 648. A '(Led.)' label is placed below the first staff of each system.



657

MIDI 1

MIDI 2

(Led.)

(Led.)

Detailed description: This system covers measures 657 to 663. MIDI 1 has two staves with rests in the treble and eighth notes in the bass. MIDI 2 has two staves; the treble staff features a series of beamed eighth notes with slurs, while the bass staff has rests. A '(Led.)' label is placed below the first staff of each system.



664 XX YY

MIDI 1

MIDI 2

(Led.)

(Led.)

Detailed description: This system covers measures 664 to 670. MIDI 1 has two staves; the treble staff has rests, and the bass staff has a half note in measure 664 followed by eighth notes. MIDI 2 has two staves; the treble staff contains a complex melodic line with many beamed eighth notes and slurs, while the bass staff has rests. Boxes labeled 'XX' and 'YY' are positioned above measures 664 and 669 respectively. A '(Led.)' label is placed below the first staff of each system.

671

MIDI 1

MIDI 2

(Ped.)

Ped.



680

MIDI 1

MIDI 2

R.H.

(Ped.)

(Ped.)



691

MIDI 1

MIDI 2

ZZ

(Ped.)

(Ped.)

Ped.

700 AAA

MIDI 1

MIDI 2

(Ped.)



710

MIDI 1

MIDI 2

(Ped.)



720 BBB

MIDI 1

MIDI 2

(Ped.)

730

MIDI 1

MIDI 2

(Red.)

(Red.)

CCC

R.H.



740

MIDI 1

MIDI 2

(Red.)

(Red.)

DDD



749

MIDI 1

MIDI 2

(Red.)

(Red.)

V.S.

EEE

758

MIDI 1

MIDI 2

(Ped.)

767

MIDI 1

MIDI 2

774

MIDI 1

MIDI 2

780

MIDI 1

MIDI 2

Ped.

786 **FFF** L.H.

MIDI 1

(Red.)

MIDI 2

Wingfield Organ, MPE
(Sounding pitch)

Red.

ROLI



796 L.H. V.S.

MIDI 1

(Red.)

MIDI 2

(Red.)

ROLI

GGG

805

MIDI 1

(Ped.)

MIDI 2

(Ped.)

ROLI

3



HHH

815

MIDI 1

(Ped.)

MIDI 2

(Ped.)

ROLI



Trigger: Patch 4

III

Part Three: Ocean

825

ROLI

1680 Chamber Organ, LFO
(Sounding pitch)

834

MIDI 1

R.H.

Red.

ROLI

844

MIDI 1

(Red.)

ROLI

854

MIDI 1

(Red.)

III

Van Straten Organ (Doof), LFO
(Sounding pitch)

MIDI 2

R.H.

Red.

ROLI

864

MIDI 1

MIDI 2

ROLI

(Red.)

(Red.)



873

MIDI 1

MIDI 2

ROLI

KKK

L.H.

(Red.)

(Red.)

882

MIDI 1

MIDI 2

ROLI

(Red.)

(Red.)



892

MIDI 1

MIDI 2

ROLI

LLL

L.H.

V.S.

(Red.)

(Red.)

MMM

899

MIDI 1

MIDI 2

ROLI

MIDI 1: Treble and bass staves with rests. (Red.)

MIDI 2: Treble staff with complex melodic line, 'L.H.' marking. Bass staff with rests. (Red.) Red.

ROLI: Treble staff with complex melodic line. Bass staff with rests.



NNN

V.S.

907

MIDI 1

MIDI 2

ROLI

MIDI 1: Treble staff with 'L.H.' marking. Bass staff with 'R.H.' marking. (Red.)

MIDI 2: Treble and bass staves with rests. (Red.)

ROLI: Treble staff with complex melodic line. Bass staff with rests.

000

914

MIDI 1

MIDI 2

ROLI

(Red.)

R.H.

L.H.

(Red.)

(Red.)



922

MIDI 1

MIDI 2

ROLI

(Red.)

R.H.

(Red.)

(Red.)

930

MIDI 1

MIDI 2

ROLI

PPP

R.H.

(*red.*)



938

MIDI 1

ROLI

V.S.

946 QQQ

MIDI 1

MIDI 2

ROLI

(Ped.)

R.H.

Ped.

R.H.



955

MIDI 1

MIDI 2

ROLI

(Ped.)

R.H.

Ped.

8va

(Ped.)

8va

963 RRR SSS

MIDI 1

MIDI 2

ROLI

972

MIDI 1

MIDI 2

ROLI

980 TTT V.S.

MIDI 2

ROLI

987 UUU

ROLI



996

ROLI



1005

ROLI



1015 VVV

ROLI

4



1024

ROLI



1033

ROLI

WWW

1041

ROLI

5

1050

ROLI

1059

1059

ROLI

1067

1067

ROLI