

## Place Hacking: Tales of Urban Exploration



# **Place Hacking: Tales of Urban Exploration**

A Thesis Presented

by

Bradley Lannes Garrett

submitted to the University of London in  
partial fulfilment of the requirements  
for the degree

DOCTOR OF PHILOSOPHY

January 2012

Department of Geography  
Royal Holloway, University of London

© Copyright by Bradley L. Garrett 2012

All Rights Reserved

Cover photo by Otter at Silent UK

**Declaration of Authorship**

I, Bradley L. Garrett, hereby declare that this thesis and the work presented in it is entirely my own. Where I have consulted the work of others, this is always clearly stated.

Signed: \_\_\_\_\_

Date: \_\_\_\_\_

## **Dedication**

This thesis is dedicated to everyone who makes life what they want it to be and to my friends who taught me what it means to be free. These pages were born from hope and desire and action. Those things were not given to me but I was shown the door. I can only hope what I found on the other side seeps beyond the binding.

## Acknowledgments

First and foremost, thank you to Marcia and Jack Kulpa, Erpel Garrett, the Bailey family and Philip Moore. You were all instrumental in the completion of this PhD from beginning to end. Apologies for being an absconded family member for the past five years.

Thank you to everyone at the Department of Geography at Royal Holloway, University of London, for the incredible level of support you have offered. Phil Crang, David Gilbert, Felix Driver and Alastair Pinkerton offered key advice during this research. I also owe a huge debt of gratitude Katherine Brickell for reading my work, inspiring me and keeping me on track. Thanks finally, and most importantly, to Tim Cresswell for your unwavering support (and occasional blind eye) during late night frantic calls and early morning coffee chugging sessions at the London Review Bookshop.

I have had some great conversations and received encouragement from Katie Draper, Noel Jenkins, Simon Cornwell, Trevor Paglen, Troy Paiva, Adam Fish and the crew at Savage Minds, Matthew O'Brien, Anja Kanngieser, Julie Harris, Michael Cook, Steve Duncan, April Ward, Jay Owens (hautepop), Justin Pickard, Paul Dobraszczyk, April Ward, Alan Rapp, Erika Sigvardsdotter, Julia Solis and Oli Mould. Cheers all.

Thanks to Statler, "Gary", Patch, Silent Motion, Winch, Marc Explo, Furtle, River Monkey, John Doe, Thelma and Towanda, Tony H., Moses Gates, The UE Kingz, Brescia Underground, Shotgun Mario, Darlin Clem, Yaz, Neb, Dsankt, Iris, Urban Fox, Guerrilla Exploring, The Badman, Claire-Elise, Gigi, LutEx, Hydra, Ercle, NickT, Eotech, Ogof, Curly, Site, Nel, Curly, Jess, Urbanity, Spungletrumpet, Ojay, Kevin

Arnold, Alias, Witek, Sarah, Brickman, Dicky, Otter, LutEx, Drainpipe, Keitei, Cogito, Hount, Olivier, Kat, Brosa, King Rat, Joel and Jesse Childers, Siologen, Snappel, User Scott, El Gringo, Pip, Agent M, Midnight Runner, Vanishing Days, Solar Powered and everyone else who I have I explored with.

A special thanks is also owed to Winch for organizing our legendary road trips described in this thesis and the Statler for driving. I am grateful to Marc Explo for being my best friend and most consistent exploring partner and for his in-action philosophising that always sent me back to the drawing board. Silent Motion set the bar high and offered a gentle push when I needed it. Patch, we've been lucky to have you around to keep our eyes open to opportunities even we would miss. And cheers to Otter for stepping up to the plate on the video work – that obviously belonged in your hands.

I owe another final thanks to Winch for being the first (and probably last!) explorer to read this thesis cover to cover, your comments were and are invaluable. As with any ethnographic study, it will become obvious as you read through that this is, in many ways, a co-authored work between myself and everyone I have undertaken this project with – thanks again all for your thoughts, support and participation, it's been a pleasure. I hope you enjoy it.

**Abstract**

“But what a strange geography lesson I was given!”  
-(Antoine de Saint-Exupéry 1939 p. 7)



Figure 1. Place Hacking: urban exploration and infiltration, under London, photo by author



Urban exploration is a practice of researching, discovering and physically exploring temporary, obsolete, abandoned, derelict and infrastructural areas within built environments. Through charting the rise to prominence of a London urban exploration crew between 2008 and 2011, of which I became an active member, I posit that urban explorers are one of many groups reacting to increased surveillance and control over urban space by undertaking embodied urban interventions in the city that undermine clean spatio/temporal narratives.

The primary research questions stem from my attempts to interrogate the practice from the inside out: Who are urban explorers? What does it involve? Why do they do it? What do they think it will accomplish? While the thesis focuses primarily on 220 explorations undertaken with my primary ethnographic group in London between 2008 and 2011, it also speaks to the urban exploration “scene” that has developed over the past twenty years in cities all over the world.

The results that emerge from the research both compliment and complicate recent work within geography around issues of surveillance, resistance, hacking and urban community building and lays out a new account, never before outlined in such detail, of the tales of urban exploration taking place in contemporary cities across the globe.

This visual ethnography is comprised of text (75,000 words), photographs (200) and video (10 shorts). The ethnographic video components can be found on the Place Hacking video channel located at <http://vimeo.com/channels/placehacking> or on the DVD in the back of this document. I suggest watching all 10 short videos before reading the thesis.

## Table of Contents

Acknowledgments .....	vi
Abstract .....	viii
Table of Contents .....	x
List of Figures .....	xi
Argot Glossary .....	xvi
<b>Chapter 1 – Urban exploration and infiltration .....</b>	<b>1</b>
Place Hacking .....	14
Researcher/explorer/community .....	18
Participation .....	18
Demographics .....	19
Style and research structure.....	25
Situating urban exploration.....	27
Formally informal - urban exploration as practice.....	31
<b>Chapter 2 – Methodological frameworks .....</b>	<b>42</b>
Doing visual (auto)ethnography.....	42
Autoethnography .....	47
Visual ethnography for a visual culture.....	51
Accidental participatory videography.....	62
Expect the unexpected .....	66
<b>Chapter 3 – Assaying history: creating temporal junctions .....</b>	<b>67</b>
A life in ruins .....	68
The preservation anxiety club.....	74
Reimagining remembered place – the recent past .....	87
Do-it-yourself interpretation: past mastering dark histories.....	96
Anticipated transience and architectural agency.....	108
Post-human imaginaries: mortal architecture .....	117
Temporal junctions: the past and imagined future in the present .....	131
<b>Chapter 4 – The rise of an infiltration crew.....</b>	<b>136</b>
The tipping point – cracking the Ministry of Defence .....	137
Getting high.....	151
Doing edgework.....	165
The sub in subterranean – sneaking under the city .....	174
New tactics: high invisibility and social engineering.....	186
Sneaking around, failing and getting busted .....	190
The first grail - hacking the London Underground.....	199
Unsecuring Iron Mountain secure file storage .....	209
Professional infiltrators, leaking spatial secrets.....	214
<b>Chapter 5 – Recoding the city through bodywork.....</b>	<b>220</b>
The sensory surreal.....	245
Sociopathic metabolism.....	252
The right to fear.....	257
The meld: urban bodies .....	262
A case study in draining.....	264
<b>Chapter 6 – Pedestals built on crumbling stone.....</b>	<b>288</b>
The myth of the Mail Rail decoded.....	293
House of cards.....	302
The alternative.....	311
Future fragmentation .....	314
<b>Epilogue .....</b>	<b>332</b>
<b>Appendix A – Snowball sample spreadsheet .....</b>	<b>350</b>
<b>Appendix B – Exploration fieldwork database.....</b>	<b>351</b>
<b>Appendix C – Exploration location maps.....</b>	<b>357</b>

## List of Figures

FIGURE 1. PLACE HACKING: URBAN EXPLORATION AND INFILTRATION, UNDER LONDON, PHOTO BY AUTHOR .....	VIII
FIGURE 2. CROIX ROUGE DISUSED METRO STATION, PARIS, PHOTO BY AUTHOR .....	XXI
FIGURE 3. AUTHOR ON THE NEO BANKSIDE DEVELOPMENT, LONDON, PHOTO BY AUTHOR .....	1
FIGURE 4. SILENT MOTION AND MARC EXPLO, RECREATIONAL TRESPASSERS, <i>WOLFSSCHLUCHT II</i> , FRANCE, PHOTO BY AUTHOR.....	3
FIGURE 5. TEAM B ON A DISUSED BARGE, WANDSWORTH, LONDON, PHOTO BY AUTHOR.....	4
FIGURE 6. CLAIRE-ELISE CLIMBING CATHEDRAL SAINT PIERRE, BEAUVAIS, PHOTO BY AUTHOR.....	7
FIGURE 7. NEB LOOKING FOR AN OPEN WINDOW, ST. CLEMENTS HOSPITAL, LONDON, PHOTO BY AUTHOR.....	8
FIGURE 8. AUTHOR CLIMBING THE <i>PALAIS DE JUSTICE</i> , BRUSSELS, PHOTO BY AUTHOR .....	10
FIGURE 9. SILENT MOTION EASILY SUBVERTING URBAN SECURITY, LONDON, PHOTO BY AUTHOR .....	11
FIGURE 10. THE HACKER ETHOS: DO WHAT YOU WANT, WHEN YOU WANT, WHERE YOU WANT, PARIS METRO, PHOTO BY AUTHOR.....	13
FIGURE 11. WINCH EMERGING FROM THE RIVER WESTBOURNE, LONDON, PHOTO BY AUTHOR.....	17
FIGURE 12. AN ENCAMPMENT FOUND IN A DERELICT SOVIET MILITARY BASE IN THE FOREST, GERMANY, PHOTO BY AUTHOR .....	24
FIGURE 13. "GARY" EXPLORING A BUNKER, DOVER, PHOTO BY AUTHOR .....	28
FIGURE 14. WINCH CRAWLING THROUGH THE PARIS "CATACOMBS", PHOTO BY AUTHOR .....	32
FIGURE 15. SILENT MOTION ON A BATTERSEA POWER STATION CHIMNEY, LONDON, PHOTO BY AUTHOR.....	38
FIGURE 16. "GARY" AT SPILLERS MILLENNIUM MILLS, LONDON, PHOTO BY AUTHOR .....	41
FIGURE 17. THE AUTHOR WITH TEAM B, EARLY 2010, TEMPLE COURT, LONDON, PHOTO BY AUTHOR .....	43
FIGURE 18. STATLER, "GARY" AND THE AUTHOR AT THE SOVIET BASE <i>VOGELSANG</i> , GERMANY, PHOTO BY WINCH..	45
FIGURE 19. KOPS BREWERY, THE FIRST LOCATION THE AUTHOR EXPLORED IN THE CITY, LONDON, PHOTO BY AUTHOR .....	50
FIGURE 20. MY EQUIPMENT FOR FIELDWORK DURING ROAD TRIPS, PHOTO BY AUTHOR.....	52
FIGURE 21. CAMERA NERDS: VANISHING DAYS, MARC EXPLO AND AUTHOR, HAWKHURST MANSION, KENT, PHOTO BY AUTHOR.....	53
FIGURE 22. "GARY" AND WINCH TYING OFF ROPES TO DROP INTO THE PRE-METRO, ANTWERP, PHOTO BY AUTHOR .....	54
FIGURE 23. WINCH CROSSING THE LIMINAL SECURITY ZONE AT NEO BANKSIDE, LONDON, PHOTO BY AUTHOR .....	60
FIGURE 24. AUTHOR FILMING AT THE 2011 INTERNATIONAL DRAIN MEET, LONDON, PHOTO BY LUCA CARENZO..	65
FIGURE 25. <i>KASTEEL VAN MESEN</i> , BELGIUM, PHOTO BY AUTHOR.....	67
FIGURE 26. URBAN CAMPING IN <i>KASTEEL VAN MESEN</i> , BELGIUM, PHOTO BY AUTHOR.....	69
FIGURE 27. AN ARTEFACT JUMBLE AT THE WEST PARK ASYLUM, SURREY, PHOTO BY AUTHOR.....	71
FIGURE 28. THE ABANDONED FACTORY <i>SINTERANLAGE</i> , GERMANY, PHOTO BY AUTHOR .....	75
FIGURE 29. A ROOM IN A STATE OF ARRESTED DECAY, BODIE GHOST TOWN, CALIFORNIA, PHOTO BY AUTHOR .....	78
FIGURE 30. SOMETHING(S) IN TRANSITION, <i>SALVE MATER</i> SANATORIUM, BELGIUM, PHOTO BY AUTHOR.....	78
FIGURE 31. A BEAUTIFULLY TOXIC DUMPING GROUND, <i>LA COKERIE D'ANDERLUES</i> , BELGIUM, PHOTO BY AUTHOR ..	80
FIGURE 32. THE APPEAL OF INDUSTRIAL DECAY, <i>COKERIE ZOLLVEREIN</i> , GERMANY, PHOTO BY AUTHOR .....	82
FIGURE 33. URBAN CAMPING ROAD TRIP, KOSMOS HOTEL, BELGIUM, PHOTO BY AUTHOR.....	84
FIGURE 34. WINCH, THE AUTHOR, STATLER AND SILENT MOTION INSIDE THE KOSMOS HOTEL, PHOTO BY AUTHOR .....	85
FIGURE 35. RUIN INFILTRATION AS PLAY, "GARY" AND AUTHOR HIDING FROM THE SECURITY PATROL, SPILLERS MILLENNIUM MILLS, LONDON, PHOTO BY AUTHOR.....	86
FIGURE 36. THE AUTHOR LOOKING OUT OVER THE <i>SINTERANLAGE</i> FACTORY, GERMANY, PHOTO BY AUTHOR.....	87
FIGURE 37. HISTORY IN THE MAKING, UNIVERSITY OF LIEGE, BELGIUM, PHOTO BY AUTHOR .....	89
FIGURE 38. ARTEFACT? PLACE? WASTE? ART? <i>MONTZEN GARE</i> , BELGIUM, PHOTO BY AUTHOR .....	90
FIGURE 39. BOTANICAL INTERVENTION, <i>CRISTALLERIE DU VAL SAINT LAMBERT</i> , BELGIUM, PHOTO BY AUTHOR.....	91
FIGURE 40. A RELIEF OF LENIN AT THE SOVIET MILITARY BASE <i>VOGELSANG</i> , GERMANY, PHOTO BY AUTHOR .....	94
FIGURE 41. SOPHIE AND THE AUTHOR PLAYING WITH A CONTROL PANEL IN ABBEY MILLS PUMPING STATION .....	95
FIGURE 42. PAST MASTERING: THE AUTHOR WEARING A NAZI SOLDIER HELMET, POLAND, PHOTO BY WINCH .....	96
FIGURE 43. INSIDE A SOVIET MILITARY GYMNASIUM, SOVIET BASE <i>VOGELSANG</i> , GERMANY, PHOTO BY AUTHOR.....	98
FIGURE 44. A CONTINUING MELD, <i>CHÂTEAU DE NOISY</i> , BELGIUM, PHOTO BY AUTHOR.....	99
FIGURE 45. RIVER MONKEY LYING IN SOMEBODY ELSE'S COFFIN, <i>SALVE MATER</i> SANATORIUM, BELGIUM.....	100
FIGURE 46. THE AUTHOR, SILENT MOTION, WINCH AND STATLER CAMPING AT THE SOVIET HOSPITAL <i>GRABOWSEE</i> , GERMANY, PHOTO BY AUTHOR .....	101
FIGURE 47. A CHILD'S SHOES LEFT BEHIND IN THE WEST PARK ASYLUM, SURREY, PHOTO BY AUTHOR.....	105
FIGURE 48. A DECREPIT DOLL, WEST PARK ASYLUM, SURREY, PHOTO BY AUTHOR .....	105
FIGURE 49. THE WEST PARK ASYLUM, SURREY, PHOTO BY AUTHOR .....	106

FIGURE 50. TIME IS HAPPENING RIGHT NOW, <i>CRISTALLERIE DU VAL SAINT LAMBERT</i> , BELGIUM, PHOTO BY AUTHOR .....	108
FIGURE 51. NOTES FROM ANOTHER TIME NOW, <i>LA COKERIE D'ANDERLUES</i> , BELGIUM, PHOTO BY AUTHOR .....	108
FIGURE 52. WHITTINGHAM ASYLUM, LANCASHIRE, DECEMBER 2007, PHOTO BY WINCH .....	111
FIGURE 53. WHITTINGHAM ASYLUM, LANCASHIRE, JULY 2009, PHOTO BY WINCH .....	111
FIGURE 54. STEPPING INTO THE UNKNOWN, ST JOSEFSHEIM MONASTERY, GERMANY, PHOTO BY AUTHOR.....	113
FIGURE 55. SLEEPING IN SOVIET BASE VOGELSANG, BERLIN, PHOTO BY AUTHOR.....	113
FIGURE 56. THE POST-INDUSTRIAL PRESENT? <i>CRISTALLERIE DU VAL SAINT LAMBERT</i> , BELGIUM, PHOTO BY AUTHOR. ....	115
FIGURE 57. A CONTINUING LIFE OF HEAVY INDUSTRY, <i>SCHWERMASCHINENBAU</i> , GERMANY, PHOTO BY AUTHOR....	115
FIGURE 58. AUTHOR AT THE POST-APOCALYPTIC BURTON BREWED BITTER SITE, LONDON, PHOTO BY AUTHOR ..	117
FIGURE 59. IMAGINED RUINS OF JOHN SOANE'S BANK OF ENGLAND, BY JOSEPH MICHAEL GANDY (1830), IMAGE VIA WIKIMEDIA COMMONS .....	118
FIGURE 60. SILENT MOTION AND MARC EXPLO IN THE URBAN TRAINING GROUND, <i>WOLFSSCHLUCHT II</i> , NEAR PARIS, PHOTO BY AUTHOR .....	120
FIGURE 61. URBAN EXPLORATION OFTEN REVEALS THE DISTURBING, THE HORROR LABS, BELGIUM, PHOTO BY AUTHOR .....	121
FIGURE 62. THE AUTHOR DESCENDING INTO THE CLAPHAM SOUTH BUNKER, LONDON, PHOTO BY AUTHOR.....	123
FIGURE 63. THE AUTHOR INSIDE THE CLAPHAM NORTH BUNKER, LONDON, PHOTO BY AUTHOR .....	124
FIGURE 64. ALMOST FORGOTTEN, UNIVERSITY OF LIEGE, BELGIUM, PHOTO BY AUTHOR.....	126
FIGURE 65. MARC EXPLO, STATLER, SILENT MOTION, WINCH AND THE AUTHOR SLEEPING IN THE QUARRIES OF PARIS, PHOTO BY AUTHOR.....	127
FIGURE 66. THE AUTHOR COMMANDEERING A DISUSED MILITARY VEHICLE IN A FORMER NATO BUNKER, NEAR PARIS, PHOTO BY AUTHOR.....	129
FIGURE 67. MARC EXPLO IN NGTE PYESTOCK, FARNBOROUGH, PHOTO BY AUTHOR .....	131
FIGURE 68. SLIPPAGE AT THE ABANDONED UNIVERSITY OF LIEGE, BELGIUM, PHOTO BY AUTHOR.....	133
FIGURE 69. TIME CHURNING, <i>BARENQUELL</i> BREWERY, BERLIN, PHOTO BY AUTHOR.....	135
FIGURE 70. JULES IN THE CLAPHAM NORTH BUNKER, LONDON, PHOTO BY AUTHOR .....	136
FIGURE 71. THE FIRST STEPS INTO BURLINGTON BUNKER, WILTSHIRE, PHOTO BY AUTHOR .....	138
FIGURE 72. BURLINGTON WAS AN ARCHAEOLOGICAL TREASURE TROVE, OUR PERSONAL MUSEUM FOR A NIGHT, BURLINGTON BUNKER, WILTSHIRE, PHOTO BY AUTHOR.....	139
FIGURE 73. TEAM B REVIEWING MAPS, PLANNING OUR EXPLORATION OF BURLINGTON BUNKER, WILTSHIRE, PHOTO BY AUTHOR.....	139
FIGURE 74. SILENT MOTION, NEB AND STATLER FIGURE OUT HOW TO START THE "BURLY BUGGIES", BURLINGTON BUNKER, WILTSHIRE, PHOTO BY AUTHOR. ....	141
FIGURE 75. A TEMPORARY PUBLIC REAPPROPRIATION OF MILITARY RESOURCES, BURLINGTON BUNKER, WILTSHIRE, PHOTO BY AUTHOR. ....	141
FIGURE 76. BANNED FOR LIFE FROM 28 DAYS LATER, SCREENSHOT VIA AUTHOR .....	144
FIGURE 77. MARC EXPLO'S 29 <sup>TH</sup> BIRTHDAY IN KING'S REACH TOWER: THE FORMATION OF THE LCC, PHOTO BY OTTER.....	147
FIGURE 78. MARC EXPLO IN THE GLC PIPE SUBWAYS, ONE OF OUR FIRST LIVE INFILTRATIONS, LONDON, PHOTO BY AUTHOR .....	147
FIGURE 79. ATOP STRATA, ELEPHANT & CASTLE, LONDON, PHOTO BY SILENT MOTION.....	151
FIGURE 80. THE AUTHOR CLIMBING THE CRANE ON NEW COURT, CITY OF LONDON, PHOTO BY AUTHOR .....	153
FIGURE 81. INFILTRATING THE PARIS METRO SYSTEM WITH MARC EXPLO, PARIS, PHOTO BY AUTHOR .....	154
FIGURE 82. ABOVE PARIS, ST-SULPICE CATHEDRAL, PARIS, PHOTO BY AUTHOR.....	155
FIGURE 83. MARC EXPLO CLIMBING THE SHARD, LONDON BRIDGE, PHOTO BY AUTHOR.....	158
FIGURE 84. ON THE ROOF OF TEMPLE COURT, CITY OF LONDON, PHOTO BY AUTHOR .....	160
FIGURE 85. THE AUTHOR AND HYDRA DANCING ON THE ROOF OF THE GILLETTE FACTORY, LONDON, PHOTO BY SILENT MOTION .....	161
FIGURE 86. PATCH IN THE BARBICAN UTILITY TUNNELS, LONDON, PHOTO BY AUTHOR .....	163
FIGURE 87. THE AUTHOR AT PLAY, <i>ST JOSEFSHEIM</i> MONASTERY, GERMANY, PHOTO BY AUTHOR.....	164
FIGURE 88. DOING OUR EDGEWORK, SILENT MOTION ON HERON TOWER, CITY OF LONDON, PHOTO BY SILENT MOTION.....	166
FIGURE 89. "GARY" DOING HIS EDGEWORK, ABSEILING 30 METERS INTO THE PRE-METRO VENTILATION SHAFT, ANTWERP, PHOTO BY AUTHOR .....	168
FIGURE 90. "GARY" "BUILDS" THE SHARD, LONDON, PHOTO BY AUTHOR .....	170
FIGURE 91. THE AUTHOR ON TOP OF THE SHARD, LONDON, PHOTO BY AUTHOR.....	171
FIGURE 92. THE AUTHOR IN THE COLOSSUS OF THE SOUTH (COTS) DRAIN, BRIGHTON, PHOTO BY AUTHOR.....	174
FIGURE 93. NEGLECTED PUBLIC INFORMATION, THE POST-WAR INFRASTRUCTURAL LAYOUT OF THE CITY OF LONDON, PHOTO BY AUTHOR.....	176
FIGURE 94. BREACHING THE THRESHOLD, LONDON, PHOTO BY AUTHOR.....	178

FIGURE 95. LIGHT PAINTING A BUNKER IN DOVER, PHOTO BY VANISHING DAYS AND AUTHOR.....	180
FIGURE 96. PLAYFUL LIGHTING, RUBIX, RIVER EFFRA, SOUTH LONDON, PHOTO BY SILENT MOTION, STATLER AND AUTHOR .....	180
FIGURE 97. YAZ AND THE AUTHOR AT LUCKY CHARMS, RIVER EFFRA, SOUTH LONDON, PHOTO BY OTTER, YAZ AND AUTHOR .....	184
FIGURE 98. WINCH IN THE RIVER TYBURN, WEST LONDON, PHOTO BY WINCH AND AUTHOR .....	184
FIGURE 99. AUTHOR KNEE-DEEP IN SEWAGE, RIVER EFFRA, SOUTH LONDON, PHOTO BY AUTHOR.....	186
FIGURE 100. WINCH AND NEB IN COSTUME POPPING A LID, LONDON, PHOTO BY AUTHOR.....	188
FIGURE 101. A “STOP AND SEARCH” FORM RECEIVED BY THE AUTHOR FROM THE LONDON METROPOLITAN POLICE AFTER BEING SEEN CLIMBING A CRANE, IMAGE VIA LONDON MET AND AUTHOR.....	190
FIGURE 102. OH US? WE'RE JUST PHOTOGRAPHERS... PHOTO BY AUTHOR.....	194
FIGURE 103. GAINING ACCESS TO DOWN STREET ABANDONED LONDON UNDERGROUND STATION, PHOTO BY AUTHOR .....	198
FIGURE 104. THE INFILTRATION OF THE LONDON UNDERGROUND, DOWN STREET STATION, LONDON, PHOTO BY AUTHOR .....	199
FIGURE 105. OUR FIRST DISUSED LONDON UNDERGROUND STATION INFILTRATION, MARK LANE, LONDON, PHOTO BY AUTHOR.....	200
FIGURE 106. SIGNAGE AT LORD'S DISUSED STATION, METROPOLITAN LINE, PHOTO BY AUTHOR.....	201
FIGURE 107. CHECKING THE TRACKS AT LORD'S DISUSED STATION, LONDON, PHOTO BY AUTHOR .....	202
FIGURE 108. KINGSWAY TRAMWAY, LONDON, PHOTO BY AUTHOR.....	204
FIGURE 109. THE “HOLY GRAIL” OF THE LONDON UNDERGROUND, ALDWYCH DISUSED STATION, PHOTO BY AUTHOR .....	205
FIGURE 110. SILENT MOTION IN THE "MAGIC DOOR", LONDON, PHOTO BY "GARY" .....	205
FIGURE 111. DOWN STREET DISUSED STATION, LONDON, PHOTO BY AUTHOR .....	206
FIGURE 112. PASSING TRAIN ON THE LONDON UNDERGROUND, DOWN STREET DISUSED STATION, LONDON, PHOTO BY AUTHOR.....	206
FIGURE 113. THE AUTHOR ON THE TRACKS OF THE PICCADILLY LINE, DOWN STREET DISUSED STATION, LONDON, PHOTO BY AUTHOR .....	207
FIGURE 114. AN IRON MOUNTAIN SECURITY ARCHIVE VAN TRANSPORTING DOCUMENTS, PHOTO BY SARAH HG... 209	209
FIGURE 115. THE SUBSURFACE LAYOUT OF A LONDON DEEP SHELTER, PHOTO VIA <a href="http://underground-history.co.uk/shelters.php">HTTP://UNDERGROUND-HISTORY.CO.UK/SHELTERS.PHP</a> .....	211
FIGURE 116. SILENT MOTION ABSEILING INTO A SECURE FILE STORAGE THROUGH THE VENTILATION SHAFT, LONDON, PHOTO BY AUTHOR.....	211
FIGURE 117. THE DISABLED MAGNETIC REED SWITCH DOOR ALARMS IN THE SECURE FILE STORAGE, LONDON, PHOTO BY SILENT MOTION .....	212
FIGURE 118. SUCCESSFUL ACCESS TO IRON MOUNTAIN'S SECURITY ARCHIVES, LONDON, PHOTO BY SILENT MOTION .....	212
FIGURE 119. SECURITY BREACH: THE AUTHOR FLIPPING THROUGH DEUTSCHE BANK ARCHIVES, LONDON, PHOTO BY AUTHOR .....	214
FIGURE 120. SECURITY GLITCH LOCATED AT ABBEY MILLS PUMPING STATION, LONDON, PHOTO BY AUTHOR .....	216
FIGURE 121. NOCTURNAL HOSPITAL INFILTRATION, LONDON, PHOTO BY AUTHOR.....	218
FIGURE 122. THE AUTHOR HAVING A BEER AND LISTENING TO NASA RADIO FEEDS IN A CRANE CAB, LONDON, PHOTO BY AUTHOR .....	219
FIGURE 123. INFILTRATION OF INFRASTRUCTURE OFFERED NEW POSSIBILITIES FOR BODILY DAMAGE, GLC PIPE SUBWAYS, LONDON, PHOTO BY AUTHOR .....	220
FIGURE 124. BODIES IN ACTION, WEST HAM STORM RELIEF, LONDON, PHOTO BY AUTHOR.....	222
FIGURE 125. SILENT MOTION AND KEĪTEĪ SNEAKING INTO THE LONDON UNDERGROUND, PHOTO BY AUTHOR.....	224
FIGURE 126. RUNNING THE TRACKS FROM LORDS TO MARLBOROUGH ROAD AND SWISS COTTAGE DISUSED STATIONS, LONDON, PHOTO BY AUTHOR .....	224
FIGURE 127. THE MOTHBALLED RUSSIAN U-475 BLACK WIDOW SUBMARINE, ROCHESTER, PHOTO BY AUTHOR. 227	227
FIGURE 128. HYDRA PLAYING INSIDE THE BLACK WIDOW SUBMARINE, ROCHESTER, PHOTO BY AUTHOR .....	227
FIGURE 129. THE AUTHOR AND SILENT MOTION CONFRONTING THE WRETCHED, "STOOP" SEWER, LONDON, PHOTO BY AUTHOR.....	230
FIGURE 130. ABSOLUTELY FILTHY! SILENT MOTION IN THE RIVER EFFRA, LONDON, PHOTO BY AUTHOR .....	230
FIGURE 131. SITE NUDE IN THE SEWER, LONDON, PHOTO BY SITE.....	232
FIGURE 132. IMPOSSIBLE PLACES, LONDON, PHOTO BY SILENT MOTION .....	233
FIGURE 133. "GARY" AND THE AUTHOR EXPERIENCING A DIFFERENT PACE IN SPILLERS MILLENNIUM MILLS, LONDON, PHOTO BY AUTHOR AND "GARY" .....	235
FIGURE 134. THE LIVING RUIN, SPILLERS MILLENNIUM MILLS, LONDON, PHOTO BY AUTHOR.....	235
FIGURE 135. STATLER NEAR RUBIX, LONDON, PHOTO BY SILENT MOTION, STATLER AND AUTHOR.....	237
FIGURE 136. "VIRGIN" ASSEMBLAGE OR CAREFULLY STAGED SET? <i>BARENQUELL</i> BREWERY, BERLIN, PHOTO BY AUTHOR .....	238

FIGURE 137. THE URBAN MARGIN, SCHWERMASCHINENBAU, GERMANY, PHOTO BY AUTHOR.....	239
FIGURE 138. THE BEAUTY OF THE SPECTACLE, KING'S REACH TOWER, SOUTH LONDON, PHOTO BY LUTEX AND AUTHOR .....	241
FIGURE 139. THE JOURNEY INTO THE PARIS CATACOMBS WITH MARC EXPLO AND HYDRA, PHOTO BY AUTHOR....	242
FIGURE 140. MARC EXPLO AND THE AUTHOR AFTER BEING CAUGHT EXITING A MANHOLE IN PARIS, PHOTO BY HYDRA .....	244
FIGURE 141. A GATHERING IN THE ILLEGAL UNDERGROUND CINEMA, PARIS, PHOTO BY AUTHOR .....	245
FIGURE 142. THE AUTHOR IN THE PIMLICO STEAM TUNNELS, LONDON, PHOTO BY AUTHOR.....	248
FIGURE 143. ACTIVATED: THE LCC IN KING'S REACH TOWER, LONDON, PHOTO BY AUTHOR .....	249
FIGURE 144. MARC EXPLO IN THE ST-MARTIN DISUSED STATION, PARIS, PHOTO BY AUTHOR AND MARC EXPLO .	250
FIGURE 145. THE AUTHOR IN A METRO LINE EXTENSION BEFORE TRACKS ARE LAID, PARIS, PHOTO BY AUTHOR AND OTTER.....	251
FIGURE 146. THE AUTHOR ACTING ON A DESIRE TO FEAR, PARIS, PHOTO BY AUTHOR .....	254
FIGURE 147. CHILDISH BEHAVIOUR: SILENT MOTION SPINNING IN AN OFFICE CHAIR, GILLETTE FACTORY, HOUNSLOW, PHOTO BY AUTHOR .....	256
FIGURE 148. THE AUTHOR DOING EDGEWORK AT <i>LANDSCHAFTEPARK DUISBERG NORD</i> , GERMANY, PHOTO BY WINCH .....	258
FIGURE 149. STATLER AT THE INTERNATIONAL DRAIN MEET, LONDON, PHOTO BY LUTEX .....	261
FIGURE 150. THE AUTHOR EXPERIENCING THE MELD; THE BODY IN THE CITY AND CITY IN THE BODY, THE RIVER WESTBOURNE, LONDON, PHOTO BY AUTHOR .....	263
FIGURE 151. 1930 LONDON DRAIN MAP USED BY THE LCC, IMAGE VIA <a href="http://www.sewerhistory.org">HTTP://WWW.SEWERHISTORY.ORG</a> .....	264
FIGURE 152. VICTORIANS IN ABBEY MILLS PUMPING STATION, LONDON, 1868, IMAGE VIA <a href="http://ragpickinghistory.co.uk">HTTP://RAGPICKINGHISTORY.CO.UK</a> .....	266
FIGURE 153. EXPLORERS IN ABBEY MILLS PUMPING STATION, LONDON, 2011, PHOTO BY AUTHOR .....	266
FIGURE 154. THE PARIS SEWERS, PHOTO BY OTTER, WINCH AND AUTHOR .....	267
FIGURE 155. FURTLE INSIDE THE COLOSSUS OF THE SOUTH, BRIGHTON, PHOTO BY AUTHOR AND FURTLE .....	269
FIGURE 156. THE AUTHOR AND MARC EXPLO AT "UNIBROW", LONDON, PHOTO BY AUTHOR AND MARC EXPLO .	271
FIGURE 157. AN 1864–65 PHOTO BY FÉLIX NADAR OF THE PARIS SEWERS, IMAGE VIA (GANDY, 1999).....	273
FIGURE 158. A 2011 LCC RESHOOT OF NADAR'S 1865 PHOTO, PARIS, PHOTO BY OTTER, MARC EXPLO AND THE AUTHOR .....	274
FIGURE 159. THE FATHER OF LONDON DRAINING, SIR JOSEPH BAZALGETTE, IMAGE VIA <a href="http://www.thameswater.co.uk">WWW.THAMESWATER.CO.UK</a> .....	275
FIGURE 160. THE AUTHOR HACKING BAZALGETTE'S HIDDEN LEGACY, THE RIVER WESTBOURNE, LONDON, PHOTO BY AUTHOR .....	276
FIGURE 161. BIOLOGICAL PACKETS, HYDRA AND MARC EXPLO, QUARRIES OF PARIS, PHOTO BY AUTHOR.....	279
FIGURE 162. CROWDING THE EDGE OF FEAR, MOUNTROUGE, PHOTO BY AUTHOR.....	280
FIGURE 163. OUTMODDED INFRASTRUCTURE, USELESS ORGAN, CONTROL ROOM A, BATTERSEA POWER STATION, LONDON, PHOTO BY AUTHOR.....	282
FIGURE 164. USER SCOTT ELECTRONICALLY HACKING LIFT CONTROLS, PHOTO BY SILENT MOTION .....	283
FIGURE 165. MARC EXPLO MEDITATING, QUARRIES OF PARIS, PHOTO BY SILENT MOTION AND AUTHOR .....	284
FIGURE 166. THE AUTHOR LYING IN THE BONES OF THE DEAD, QUARRIES OF PARIS, PHOTO BY AUTHOR .....	285
FIGURE 167. THE AUTHOR EXPLORING THE PARIS METRO, LEARNING THE CITY FROM THE INSIDE OUT, PARIS, PHOTO BY AUTHOR.....	287
FIGURE 168. BROSA WIGGLING THROUGH A SECURITY LOOPHOLE, ABBEY MILLS PUMPING STATION, LONDON, PHOTO BY AUTHOR .....	288
FIGURE 169. THE GROUP CRACKED TUBE STATIONS NEVER PREVIOUSLY EXPLORED, BROMPTON ROAD DISUSED STATION, LONDON, PHOTO BY "GARY" .....	290
FIGURE 170. THE AUTHOR WITH DRAINPIPE AT MY LEAVING PARTY, CLAPHAM BUNKER, LONDON, PHOTO BY COGITO .....	292
FIGURE 171. THE AUTHOR'S SQUAT IN CLAPHAM, CONVERTED INTO THE BRAD:PAD/TEAM B WAR ROOM, LONDON, PHOTO BY COGITO.....	292
FIGURE 172. ACCESSING A HOLY GRAIL, LONDON, PHOTO BY SILENT MOTION .....	295
FIGURE 173. MOTHBALLED SUBTERRANEAN INDUSTRY, LONDON, PHOTO BY STATLER.....	295
FIGURE 174. TUNNEL VISION IN THE MAIL RAIL, LONDON, PHOTO BY "GARY" .....	297
FIGURE 175. MINI YORK TRAINS IN THE MAIL RAIL, LONDON, PHOTO BY PATCH.....	297
FIGURE 176. SNAPPEL, URBAN FOX AND SIOLOGEN IN THE MAIL RAIL, LONDON, PHOTO BY URBAN FOX.....	299
FIGURE 177. RECREATIONAL CRIMINALITY, LONDON, PHOTO BY PATCH .....	301
FIGURE 178. AN ERROR IN THE CODE, LONDON, PHOTO BY AUTHOR.....	302
FIGURE 179. INFILTRATION PARAPHERNALIA, TEAM B WAR ROOM, LONDON, PHOTO BY AUTHOR .....	306
FIGURE 180. SOME KEYS OPEN MORE DOORS THAN OTHERS, LONDON, PHOTO BY AUTHOR.....	306
FIGURE 181. THE BOARDED UP BRAD:PAD/WAR ROOM IN CLAPHAM, LONDON, PHOTO BY AUTHOR.....	308
FIGURE 182. THE AUTHOR HIDING FROM DRIVERS IN THE METRO, PARIS, PHOTO BY AUTHOR.....	313

FIGURE 183. THE AUTHOR LYING ON THE TRACKS IN THE ARSENAL DISUSED STATION, PARIS, PHOTO BY AUTHOR	313
FIGURE 184. WATCHING THE BONFIRE NIGHT FIREWORKS FROM A CHIMNEY OF BATTERSEA POWER STATION, PHOTO BY AUTHOR .....	314
FIGURE 185. "GARY" JUST HAVING A LOOK, BELGIUM, PHOTO BY AUTHOR .....	317
FIGURE 186. THE TRIBE, KING'S REACH TOWER, LONDON, PHOTO BY AUTHOR .....	318
FIGURE 187. IT TOOK A CREW, LONDON, PHOTO BY AUTHOR .....	319
FIGURE 188. EXPLORERS EXHIBIT DEEP CARE FOR THE CITY, DERELICT BARGE, LONDON, PHOTO BY MARC EXPLO .....	319
FIGURE 189. SILENT MOTION CLIMBING THE IMPOSSIBLE, LONDON, PHOTO BY AUTHOR .....	320
FIGURE 190. A PORTAL TO OUR CITY, LONDON, PHOTO BY AUTHOR.....	321
FIGURE 191. PATCH AND OTTER BACKCABBING A METRO TRAIN, PARIS, PHOTO BY AUTHOR .....	324
FIGURE 192. A VIEW WE CAN NEVER SEE AGAIN, LONDON, PHOTO BY AUTHOR .....	324
FIGURE 193. STRADDLING THE EDGE OF THE FORBIDDEN, PHOTO BY AUTHOR .....	326
FIGURE 194. PROBING THE LIMITS OF THE URBAN, LONDON, PHOTO BY SILENT MOTION .....	327
FIGURE 195. A COMMUNITY THAT MUST BE BUILT, PATCH, LUTEx, "GARY", SILENT MOTION, LONDON, PHOTO BY AUTHOR .....	328
FIGURE 196. DOING EXCEPTIONAL THINGS THAT AREN'T ON OFFER, "GARY", WINCH, GIGI AND THE AUTHOR, LONDON, PHOTO BY AUTHOR.....	328
FIGURE 197. THERE ARE ALWAYS NEW ADVENTURES TO BE HAD, BERLIN, PHOTO BY AUTHOR.....	330
FIGURE 198. ANOTHER SIDE OF WHAT YOU KNOW, REVEALED BY URBAN EXPLORATION, PRE-METRO, ANTWERP, PHOTO BY AUTHOR .....	331
FIGURE 199. THE GROWTH OF AN IDEA, LONDON 2012, PHOTO BY AUTHOR .....	332
FIGURE 200. SIMPLICITY, PHOTO BY SILENT MOTION .....	333

## Argot Glossary

**The 3<sup>rd</sup>** – The third rail that provides power to electric trains (for instance in the London Tube and Paris Metro).

**Access/Access details** – The way in which one gains entry to a location. Access details are shared carefully.

**Admin** – The administration building of a derelict hospital/asylum.

**ARTS** – Abandoned Rapid Transit Stations.

**Asylum Seeker** – An explorer who primarily explores abandoned asylums.

**Backcabbng** – Riding in the back cab of a train.

**Backlighting** – a photographic technique in which something (usually a person) blocks light in front of a camera to create a photo that “pops” in the dark.

**Bait** – Acting in a way that is provocative or looks dodgy, therefore baiting police or security (i.e. “I just took a bait photo of her crowbarring that door”).

**Blagging** – talking one’s way into a place/out of a bust (see bust).

**Bricked Up** – an opening that has been bricked, blocked or cemented (see Sealed).

**Bust(ed)** – 1. Getting caught. 2. Doing something [i.e. we busted an epic (see Epic)].

**Cracking (a location)** – Opening a new location for the first time that no explorer (and likely few other people) have ever seen.

**Cubed location** – A location where one exploration connects to another and then another (i.e. a tunnel goes into the basement of a building, where you then climb to the roof [see Squared Location]).

**Derp** – 1. A derelict place, non-infrastructure. 2. A bit dull/a stripped out site.

**DOANUE** – Do an Urban Exploration.

**Drainer/Drain0r** – An explorer who is primarily interested in drains or sewers.

**DSLR** – A Digital Single Lens Reflex camera, the preferred photographic equipment for most urban explorers.



**Elite/Leet/Pro/Pr0** – An explorer or group with an (usually international) reputation for doing high-quality, new explorations.

**Edgework** – Undertaking a life-threatening risk for no reason other than to feel "the edge".

**ENOF** – Epic night of fail; everything went wrong.

**Epic** – An exploration of a very high calibre and/or a never-before-seen site.

**Fail** – 1. A failure i.e. a failed exploration. 2. The failure or the secca or cop to catch you (see secca).

**The Fresh** – Poo. Also used to describe the feeling of being in the sewer or in "in thy fresh".

**Golden Age** – The years of urban exploration in London between 2008-2011. Other cities (such as Minneapolis and New York) have different urban explorer Golden Ages.

**Group shot** – A photograph of everyone participating on an exploration.

**GTFO** – Get the Fuck Out, i.e. we've been busted (see urbanexit).

**Heras** – The name of a fence manufacturer, usually used in reference to a type of loose fence that, while easy to disassemble, makes an incredible amount of noise to climb.

**HDR** – A photographic technique that layers 3 or more shots to create a particular aesthetic effect. Most explorers have a strong opinion for or against its use.

**Hoarding** – Wooden board placed around a site to secure it.

**Hot (location)** – A location which has been posted publically online recently or that explorers were caught in, usually best to stay out of until the heat cools.

**Holy Grail** – An exploration that requires deep research and effort with a commensurate high reward at the end.

**Infiltration** – A trespass on a live site (not derelict or with workers in it).

**J Bizzle** – Joseph Bazalgette, architect of the London sewer system.

**Key** – A found/borrowed/copied key, drain key, triangle key (for lifts) or a crowbar.

**Keyboard warrior** – An explorer who “talk a lot of shit” online but doesn’t live up to it in “real life”.

**KTAs** – The Paris Catacombs (quarries under Paris).

**Layup** – Where trains are parked.

**Light painting** – Painting a dark place with light during a long exposure photograph.

**Lift surfing** – Standing on the roof of a lift box while it is moving.

**Lonely chair shot** – The photo every “noob” takes in an abandoned building of a lonely chair placed in a beam of light coming through a broken ceiling (see noob).

**Mask up** – Putting on or pulling up facemasks, usually to run by a camera.

**Midriding** – Riding trains by standing in the space between two carriages.

**Meet/Meet-up/Pissup** – A mass meeting of urban explorers.

**Ninja/Ninjors** – An explorer skilled at climbing, often sent in solo to open doors from the inside.

**No man’s land** – The area between the security fence and a building, usually where security patrols walk (see Secca).

**Noob** – A new/inexperienced explorer.

**Orb** – A light refraction in a photograph mockingly (for the most part) referred to as a spectre.

**Overcooked** – An HDR photo that has been “overdone”.

**Palisade** – A type of static, sharp, spiked metal fence. Particularly difficult to climb.

**Picked** – Using lockpicks to gain entry.

**People shot** – A photograph of people exploring (rather than the place).

**Portal** – Where an infrastructural system (ie metro) goes from underground to aboveground.

**Pranged/Pranged out** – A bit cautious/on edge after an incident that makes one wary. Some explorers are always pranged out.

**Prohobo/Probo/Urban camping** – Sleeping in abandoned places with expensive kit (gear).

**Recce** – Reconnaissance/scouting/scoping out the way inside somewhere before exploring it and/or clocking security patrols.

**Rinsed** – When a location or place (as large as a city) is thought to have been thoroughly explored.

**Rope in** – An abseil entry using ropes and harnesses.

**Ruin porn** – A fetish for the exploration and photography of ruination and dereliction.

**Secca** - Security guard.

**Sealed** - Somewhere that is, or has become, inaccessible.

**Snipping** – Cutting through a fence/lock to enter.

**Squared location** - A location which connects to another (i.e. entering a tunnel which then connects to a drain, see Cubed Location).

**Stoop** – A small sewer pipe that is painful and filthy to traverse. Also the name of a famous London drain explorer.

**Swag** – Material artefacts removed from a site.

**Tankcattling** – Smashing into/breaking into a site, through a door or lock.

**TOADS** – Temporary, Obsolete, Abandoned and Derelict Spaces.

**Trackies** – Rail workers.

**Trolling** – Purposefully antagonizing other people on forums to provoke outrage, for instance by posting access details (see access details).

**Walk in** – A site which requires little or no effort to access.

**Xmas** - A period of time when security is almost non-existent, when “epic” sites get “busted” [see Epic and Bust(ed)].

**Urban exploration/UrbEx/UE** – Undertaking a recreational trespass.

*Marc and I are sat on one of those little benches inside a Paris Metro station, you know, the ones that you would never sit on under normal circumstances, wearing black and covered in grime. I have a head torch on over my hoodie. We've basically been up for 2 days and I'm a bit loopy.*

*On the other side of the station, there are three drunken guys lying on another bench harassing people walking by. So, they are a concern. I look at the board and there are two trains arriving, one in 2 minutes and one in 6. There are various people lingering on the platform waiting for the train in 2 minutes. The people looking at their watches and mobile phones are good; they're not paying attention, likely in a rush. However, a little girl with a balloon is staring at us very intently, her parents oblivious. She knows we're up to no good. She wants in on the secret.*

*Marc looks me over and whispers "tuck that strap in on your backpack, if it gets caught and you go down, we won't make it. Remember we only have 4 minutes in-between trains." I realise with a start that by "not make it", he means we will be hit by the train arriving in 6 minutes. 5 now.*

*The next minute is the longest of my life, I feel like I can hear the heartbeat of everyone near us, my body is tingling and shaking. I stop myself from instinctively looking at the security camera and pull up my buff, covering my face a little more. By the time the wind is pushed in through the tunnel and the little electronic bells announce the arrival of the train, I'm sweating. I feel like everyone is staring at us. I push this awareness to the back of my mind as we get up slowly and walk toward the last doors of the train. The doors close just as we get to them and we both feign disappointment and turn to leave the platform. Except we don't. The last thing I see as Marc throws open the barrier on the end of the platform and we run into the dark passage onto the trembling tracks is the little girl staring at us out the window as the train pulls away, her face glowing red in the taillights (Field Notes, Paris, September, 2010).*



Figure 2. Croix Rouge disused Metro station, Paris, photo by author

## Chapter 1 – Urban exploration and infiltration

“The Age of Discovery is not dead: it lives on through urban explorers.”  
-(Deyo and Leibowitz, 2003: 146)



Figure 3. Author on the NEO Bankside development, London, photo by author

In his 2005 book *Access all Areas*, an urban explorer who wrote under the *nom de plume* Ninjalicious described urban exploration and infiltration (more colloquially known as UrbEx or UE) as “an interior tourism that allows the curious-minded to discover a world of behind-the-scenes sights” (Ninjalicious, 2005: 3). Ninjalicious is largely credited as the individual who first penned the phrases “urban exploration” and “infiltration” to describe what Troy Paiva has more recently called the discovery and exploration of T.O.A.D.S., temporary, obsolete, abandoned or derelict spaces (Paiva and Manaugh, 2008: 9). More specifically, urban explorers recreationally trespass into derelict industrial sites, closed hospitals, abandoned military installations, sewer and drain networks, transportation and utility networks, shuttered businesses, foreclosed estates, mines, construction sites, cranes, bridges and bunkers, among other places.

Urban explorers come from a wide swath of nations and vocations, all connected primarily by their interest in adventure and the preference for embodied experience over analysis or representation, seemingly in contrast to their obvious proficiency with visual media. Through networks of practitioners operating under pseudonyms and false identities, the urban exploration scene is mysterious, secretive, exclusionary and, as I will show through my ethnographic work with the community, a deeply rooted community full of rare camaraderie. A web of rich stories has formed in London from 2008-2011 with a group who refused, despite eventually very severe consequences and repercussions, to let adventure, mystery and desire wither in a world rendered increasingly mundane through what many of them see as the commercialisation (Edensor, 1999) and securitisation (Adey, 2009) of the city.

At the same time, working deeply within the community has revealed a strain of libertarian ideology, grounded in a desire for personal freedom, that also celebrates the neoliberal construction of the monolithic, all capable subject (Berg, 2011) and complicates a superficial understanding of this “movement” as simply a response to the neoliberalisation of the city (Peck and Tickell, 2002). The argument that I want to put forward here is that urban explorers, in the hacking tradition, hack or exploit fractures in physical architecture and social expectations in an effort to find deeper meanings and different readings in places even as they preference process over results. This practice, rather than being strictly oppositional, is actually quite celebratory; it is a method of affecting desire through unencumbered play that creates a meld between body and city, representations and practice, explorers and place and, of course, between fellow trespassers.



Figure 4. Silent Motion and Marc Explo, recreational trespassers, *Wolfsschlucht II*, France, photo by author

This thesis is constructed in two interlinked strands. The first is built upon my involvement in 220 explorations through eight countries with over 100 explorers (See Appendix A and B), primarily based with an urban exploration crew referred to as “London Team B” between 2008 and 2011 (though as I will show, many people involved with the crew resisted group bounding and labels). This period of time is significant, for, as I will demonstrate, “Team B” gained an international reputation during the time I explored with them through both international “urban camping” trips and an unprecedented level of exploration in London centred in the city’s infrastructure. This led to London “Team B” eventually fusing with what was “Team A” to be reframed as the “London Consolidation Crew”, now one of the most respected international urban exploration collectives in the world. The story of what it took to get there, and, to a degree, my complicities in those exploits as a member of the crew, make up one strand of this research. Those are the tales of urban exploration.





Figure 5. Team B on a disused barge, Wandsworth, London, photo by author

The second strand of this ethnography is the spatial theory behind the practice. I have posited urban exploration as a quest for a decommodified sense of the past folded into passion for a discovery of a novel present which creates temporal junctions (Garrett, 2011a and Chapter 3), an interest in the unexpected and underappreciated, and a desire to shatter illusions about control over urban environs through temporary spatial reappropriation (for similar examples of these tactics see Borden, 2001, Saville, 2008, Lyng, 1990a, Cant, 2003). Through this lens, the practice can be viewed as a tactic (de Certeau, 1984) utilized to create smooth spaces of openness, transparency and interconnectivity (Deleuze and Guattari, 1988) and to appropriate cultural heritage and material memory on local, personal and affective terms (Samuel, 1994). At the same time, while the movement may be considered, on whole, as a commentary on urban alienation, “urban explorers [themselves] largely don’t make claims beyond exercising a right to learn more about their environment” (Rapp, 2010: 3) through “firsthand experiences of the

built environment denied to the rest of us” (Rapp, 2010: 38) undertaking what Siologen, one of my project participants, has called “victimless criminal activity” (Siologen, January 2011).<sup>1</sup> These more theoretical aspects of the work are what I refer to as “place hacking”, a term I will unpack in the next section.

In the thesis, I argue that urban exploration, at its core, is about the reassertion of power over place from a population frustrated by increasing constrictions on spatial freedom (Foucault and Rabinow, 1984) affirmed through an embodied existentialist drive (Sartre and Baskin, 1967, Merleau-Ponty, 1962). However, these explorations are also, perhaps, beyond traditional notions of embodiment in their quest for experiences beyond representation or explanation (Lorimer, 2008). Urban exploration has arisen, I argue, like many preceding critical spatial practices (Rendell, 2010), as an “oppositional response to the disembodied imperatives of late capitalism” (Lyng, 2004: 360) intimately connected to canonical urban critiques including the work of the Surrealists (Breton, 1978), Situationist International or SI (Debord, 2006a, Debord, 2006c), various cultural jamming activities (see Barnard, 2004: 119), and urban subversions, yet is also deeply intertwined in modes of production, waste and change in the modern city (Hawkins and Muecke, 2003) which often can be read running parallel, rather than in opposition to, late capitalism. Finally, I contend that new research on urban exploration slots tightly into seminal geography research by Cresswell (1993, 1996) on transgression as well as Bonnett and Pinder's accounts of avant-garde urban tactics (Pinder, 2005a, Pinder, 2008, Bonnett, 1993, Bonnett, 1996b) even as the “movement” itself is largely unaware of these preceding practices and/or largely unconcerned about the spatial theory behind their motivations to explore.

---

<sup>1</sup> Unless otherwise noted, direct quotes have been recorded in person (likely on video) during the course of ethnographic research (2008-2011).

However, I also want to make a case for urban exploration and infiltration as a necessary escalation and adaptation of those previous practices and concepts, declaring an almost righteous right to spatial freedom in reaction to escalating securitisation of everyday life (the root of the perceived subjugation) well documented by geographers (Graham and Marvin, 2001) which has resulted “in structural conditions of alienation, reification, individualism and oversocialization” (Lyng, 2004: 363). I will show that urban exploration, as a practice, owes a debt to the successes and failures of these preceding movements working to actively resist spatial and social homogenization. The lessons learned from these preceding practices has led to the creation of a network of subversive practitioners that is horizontally structured, largely without leadership, and decentralized, that exudes an opaque public image of apolitical benignity, at times even presented as a type of heroic guerrilla preservationism (RomanyWG, 2010, Payne, 2009) while at the same time asserting itself politically through public valorisation of successful covert criminal undertaking. Urban exploration, as a result of its foundational internal decentralised power structure, well-groomed public image (which I have disrupted though this research) and widespread denial of dogmatic motivation, is deeply political in action but not assertion, rooted in freedom of personal choice that comes across as almost libertarian in ideology (here again we can look to Bonnett’s (1989) discussion of the entanglements between Situationism and the libertarian left). As Marc Explo, an explorer from France told me on a trespass into the Paris catacombs (quarries) (see Garrett, 2011b),

I don’t need anyone to tell me that I am free. I prove that I am free everyday by going wherever I want. If I want to drink wine on top of a church, I do that, if I want to throw a party underground, I do that (Marc Explo, September 2010).



Figure 6. Claire-Elise climbing Cathedral Saint Pierre, Beauvais, photo by author

This central motivation behind urban exploration has been parodied beautifully by the UE Kingz, a Stockholm urban exploration crew, who created a music video in a sewer called *You Have to Choose* where they implore the viewer to “live your life in a fishbowl... or climb down in a manhole”.<sup>2</sup> The central tenet of the UE Kingz philosophy is that no person, or physical barrier, can stop you from going where you want to go and doing what you want to do – that choice is always yours. This precept is also asserted by many of my project participants. It is the ultimate assertion of the right of the autonomous subject, which is itself a reflection of the neoliberal project these activities appear to resist. As the explorer and BASE jumper<sup>3</sup> Downfallen wrote, “when we see a sign that says ‘Do not enter’, we understand that this is simply a shorthand way of saying ‘leaving protected zone: demonstrate personal accountability beyond this point’” (RomanyWG, 2010: np).

---

<sup>2</sup> <http://vimeo.com/13702117> (accessed 30th November 2011).

<sup>3</sup> BASE jumping is an activity that employs an initially packed parachute to jump from fixed objects, usually illegally. "B.A.S.E." is an acronym that stands for four categories of fixed objects from which one can jump: buildings, antennae, spans, and earth (see Martha and Griffet, 2006).



Figure 7. Neb looking for an open window, St. Clements Hospital, London, photo by author

In the following passage, the American explorer youliveandyouburn highlights what he sees as urban exploration's role in liberating humanity from societal constraints,

Most of us enjoy the benefit of living in a safe society. We live within defined and defended borders. We sleep soundly under the ever reaching umbrella of government protection. Our food and water are monitored, our consumer products tested.

Cups of coffee are sold with warning labels, "this is hot." Seat belts are required on most roads in most developed countries. The benefits of this recent rise of safety cannot be denied. Infant mortality is down, life expectancy is up, and more and more people are gaining the material markers of a so called "modern world."

But what of the detriment they have caused? Adventure has become a packaged commodity. One can take an afternoon course in skydiving, or a pre-planned six day trip to Jerusalem. Even Everest has become a tourist trap. Rich men and women shelling out six figures for a guided trek (sic) up the mountain. The danger has been minimized for the convenience of the consumer; the difficult planning already done. These adventures are not adventures at all. They are vacuum packed, sanitized bastardizations of an original independent spirit.

The things [we do] are not "safe" in the way that modern society has come to understand safety. We are not experts in our field. We don't always use

tested and accepted equipment. We don't always go where it is deemed safe for us to go. The risks are plain and clear to all involved, but we face them and weigh the options. Climb that crane and take a slight risk of death or incarceration? Or stay home and watch another uninspiring television show? Rather than pursue solely the recreational products and services offered to us we choose to follow our own aims.

Want to summit that skyscraper? No need to jump through hoops trying to arrange a guided tour. Just use your own head and get up there yourself. When you abandon the child-parent relationship between yourself and society and start to act and think for yourself a whole new world will open up. The consequences truly pale in comparison because, lets face it, what we do is not that dangerous and a night in the cells is really not that bad.<sup>4</sup>

These disclosures, I hope, underscore the value of undertaking deep ethnography throughout this research. As an active member of this community, I have been able to undertake explorations with people over three years to gain insight into motivations that, within this secretive and closed community, are rarely spoken (see chapter 2 for a discussion of my methods), given that practitioners largely respects action over words. As a result, this research also speaks through action and like many urban ethnographies, is more method than theory based.

As an example, on a two-week urban camping (prohobo) road trip from England to Poland in July 2010, four of us (Winch, Statler, "Gary" and myself) explored and slept in over 50 ruins, abseiled into the never-completed Antwerp metro system and climbed a number of notable buildings including the *Palais de Justice* in Brussels. Winch, one of my primary project participants, told me that he felt urban exploration, for him, redefined the notion of "quality of life". When I asked him to elaborate, he said,

Well, I think our generation has come to realise that you can't buy real experiences, you have to *make* them. Experiences like these are what quality of life are about, it has far less to do with how much stuff you own and more to do with how you choose to spend your time (Winch, June 2010, emphasis mine).

---

<sup>4</sup> [http://www.nopromiseofsafety.com/?page\\_id=515](http://www.nopromiseofsafety.com/?page_id=515) (accessed 28th December 2011).



Figure 8. Author climbing the *Palais de Justice*, Brussels, photo by author

Winch's insistence on his right to make life what he wants it to be was exhibited throughout my time with the community and manifested in increasingly militant forms as our crew became more brazen and skilful at trespassing. Meanwhile, explorers constantly asserted to me that what they were doing was not political or even subversive – it was just something that could be done.

However, to me it was is no fortuitous coincidence that many of these adventures were based in global capital cities where everyday experiences and encounters, it has been argued, have been dulled through both sensorial overload and increased securitisation of everyday life. This has taken place as "global interconnections between highly valued spaces, via extremely capable infrastructure networks, are being combined with strengthening investment in security, access control, gates, walls, CCTV and the paradoxical reinforcement of local boundaries to movement and interaction within the city" (Graham and Marvin, 2001: 206).



Figure 9. Silent Motion easily subverting urban security, London, photo by author



Ironically, as I will demonstrate in this thesis, it is exactly these types of constructions that are most susceptible to the urban explorer's "hack", for the more complicated a system gets, the more weaknesses there are to exploit.

Another of my project participants, Silent Motion, said,

At some point you have to say 'fuck the consequences, I *need* to connect with this city, and if I have to work a little harder for that feeling then so be it' (Silent Motion, December 2010).

Urban explorers reignite everyday experience by deprogramming controlled space through both premeditated and spontaneous recreational trespass, acted out in place-making exercises that shatter the monotony of everyday experience in normative urban spaces. These explorations and expeditions, in their playful unproductiveness, are reminiscent of the pointless wanderings of the SI of 1950s Paris. Guy Debord, in *The Society of the Spectacle*, writes that "the modern spectacle depicts what society *could* deliver, but in doing so it rigidly separates what is *possible* from what is *permitted*" (Debord, 2006b: 14, italics in original). Urban explorers offer a tacit theory of seduction that slips under the net of the spectacle and returns with documentation, verging towards transgression quietly but consistently, with little or no explanation as to why or how and no central leadership with a list of demands; where they are not offered, rights to the city are simply taken. As Winch writes on his blog,

Exercising access to voidspace is not a right or a privilege, it's just something that can be done. Why should we sit and wallow in the regimentation of shallow, sterile spaces presented to us as 'safe' and appropriate for use?<sup>5</sup>

In this thesis, I contextualize this libertarian notion of simply "doing what can be done" regardless of social, cultural or legal constraints in terms of a hacker ethic (Nissenbaum, 2004). Computer hackers, like urban explorers, exploit security weaknesses for the joy of doing so, in the spirit of liberalism and meritocracy.

---

<sup>5</sup> [www.thewinch.net/?p=1724](http://www.thewinch.net/?p=1724) (accessed 6<sup>th</sup> March 2011).

However, urban explorers, like hackers, reject a static notion of what that might imply in an attempt to sidestep being associated with a movement that entails a clear narrative or motivation. As Coleman and Golub write,

...hacking, so often marginalized or misunderstood in popular culture as a sub-cultural group separate from or diametrically opposed to mainstream society, is in fact one crucial location whereby the fractured and cultural character of liberalism is given *new life and visibility* in the digital age (Coleman and Golub, 2008: 257, emphasis in original).

Both communities (even that term is problematically bounded, as I will demonstrate), while many times adopting a stance of apolitical benignity, nevertheless form a community of active political subversion, both of which move between physical and virtual space. The interstices that urban explorers locate and exploit cause what I call the meld, a collapse and fusion of the physical and the virtual, the seen and unseen, the can and can't. Those meld events have the ability to shock and inspire, but eventually come at a cost as the embarrassment of state authority figures inevitably leads to crackdowns.



Figure 10. The hacker ethos: do what you want, when you want, where you want, Paris Metro, photo by author

**Place Hacking**

“Place is the first of all beings, since everything that exists is in a place and cannot exist without a place.”

- Archytas, as cited by Simplicius (Lees and Overing, 2006)

Tim Cresswell argues that “place, at a basic level, is space invested with meaning in the context of power” (Cresswell, 2004: 12) that “must have some relationship to humans and the human capacity to produce and consume meaning” (Cresswell, 2004: 7). I suggest that urban exploration, as a cultural practice, creates alternative placial narratives and counter-spectacles through the systematic subversion of this context of power via subtly transgressive mobilities (Cresswell, 1993) that undermine dominant capitalist narratives through playfully unproductive, pointless, or at the least largely uncommodifiable action. Those actions erode perceived power by exposing spatial security flaws through gaining access to off-limits architecture. Successful explorations and infiltrations are systematically documented and retained, flaunted and used as inspirational tools that escalate the “edge” of the practice. This social practice, which sizzles with subversivness, resembles the work of computer hackers (Löwgren, 2000) – except that urban explorers are largely hack *places* rather than virtual systems. Both are elective procedures of participation in otherwise closed objects (proprietary cyberspace or off-limits architecture).

As early as the 1980s, the term “hacking” was applied first to physical space by the Technology Hackers Association at MIT who learned to pick locks and infiltrated the steam tunnels underneath the university. Students began climbing rooftops on campus, conducting freshmen on what is called the “Orange Tour” (Scott, 1993). The celebrated hacker Kevin Mitnick used to dumpster dive in Los Angeles (LA)

and find old bus passes. After acquiring a punch hole device identical to the LA Rapid Transit Authority, he would stamp out free bus transfers for passengers, one of his favourite hacks (Coleman and Golub, 2008). It wasn't until relatively recently the term "hacking" was appropriated by the virtual computing community. As Löwgren (2000: np) writes, "the word 'hack' was used to refer to... practical jokes or stunts. Its meaning shifted to the technology needed to perform the prank, and later came to mean a clever technical solution in general." The 7<sup>th</sup> entry under the term "hacker" in the New Hacker's Dictionary defines a hacker as "one who enjoys the intellectual challenge of creatively overcoming or circumventing limitations" (Raymond, 1996: 310) importantly pointing out the physical foundations of the art. As Dsankt, one of today's most well-known urban explorers writes,

Whether you're hacking transit systems or computer systems they're all fissured, all possessing those little cracks just wide enough to wriggle your dirty little fingers into and force to sneak a peek into what lies beneath the shiny smoothed over facade most [people] take for granted every single day.<sup>6</sup>

I suggest *place hacking* as a porous phrase that encapsulates various types of urban explorations. This can include urban exploration, infiltration, draining, illegal underground river boating, buildering, unauthorised spelunking, drain driving, urban adventuring, underground parties and more. The common theme here is the ability to access closed places, whether public or private, and reappropriate them for whatever temporary use is desired. In all cases, these activities encompass the more intangible themes of heritage seizure, authoritative subversion, "alternative" or sub-cultural community construction and identification. This subcultural identification is, in effect, limitless; most explorers undertake many types of exploration, refusing to be definitively categorized, while many still consider themselves specialists in particular environments. For

---

<sup>6</sup> [http://www.sleepycity.net/posts/247/The\\_London\\_Underground](http://www.sleepycity.net/posts/247/The_London_Underground) (accessed 1st December 2010).

instance, there is a dedicated transnational community of “drainers” that primarily explore drain and sewer networks (see video 9, *IDM 2011*), though most drainers do other types of urban exploration as well.

The images that urban explorers produce depicting the art of finding and entering places to create moments temporarily deprogrammed have been widely publically applauded as one of the most promising forms of contemporary photography that “speak back” to the world around us (see chapter 4). But while the organisation, practice and publication of the practice may be novel, a question remains whether the practice itself actually is. The connections I have posited to preceding movements suggest the basic premise behind the practice – acting on the instinct to explore places – is quite base. Even the Situationists, perhaps the most revolutionary of spatial hijackers, wrote that the only thing people lacked was the consciousness of what they already knew. What the SI offered, like urban explorers and hackers of today, is a glimpse at what it looks like when you start acting on your repressed impulses (Marcus, 2001: 50).

Urban exploration, over the past 20 years, has built a rich history for itself structured primarily around web forums that appears quite cohesive.<sup>7</sup> The community even extols a “code of ethics”, an ethereal code of which there is no apparent enforcing body other than the disapproval of fellow conspirators, again, much like the computer hacker “community”. However, in both cases those unified fronts contain innumerable fractures leading to a constant assertion that there is no urban exploration “community”. This ethnographic research worked largely off those forums, behind the “public image” of urban exploration.

---

<sup>7</sup> [www.uer.ca](http://www.uer.ca) is the largest global forum and [www.28dayslater.co.uk](http://www.28dayslater.co.uk) boasts the highest membership numbers in the United Kingdom. There are also dozens of small and private forums.

The results of this ethnography suggest that urban exploration, infiltration and place hacking are a way of speaking back to forces often beyond our control, asserting spatial rights simply by doing things that are not supposed to be able to be done. By producing these events, the individual creates a space to assert their agency as a being in place and melds her and himself into the urban fabric, also melding the unified subject into a deeply-bonded community - a re-enfolding into place on rewritten code - that is stacked and layered over time. That increasing connectivity, aligned with the potential for radical subjectivity, revealed and increasingly escalated through these activities, creates enticing new urbanisms. Those connections also reveal the potentiality for urban exploration to have implications beyond the immediacy of the hack, indicated through massively growing public interest in the practice.



Figure 11. Winch emerging from The River Westbourne, London, photo by author

**Researcher/explorer/community**

“Attach yourself to what you feel to be true. Begin there.”

– The Invisible Committee (2009: 97)

**Participation**

Nestor (2007) reports that the most popular global urban exploration forum in the world, the Urban Exploration Resource (UER), has 18,000 registered users. In London, there may be around 100 active urban explorers as of January 2012. When I asked Oxygen Thief, the administrator of Britain’s most prevalent forum, *28 Days Later*, if he could provide me with any statistics on registered users across Britain, he responded, “what happens on the forums has squat to do with exploring, it’s not a true reflection of anything” (Oxygen Thief, April 2010).<sup>8</sup>

Oxygen Thief’s reaction was expected; it is the reaction any superficial researcher would provoke in an attempt to approach this community, a community built around shared experiences, a community that defines itself on an obscure foundation of constant misinformation to mislead “noobs” and “cops”. Even after a year of close friendship and countless explorations together, one of my project participants called “Gary” told me, “what you do Brad, it’s just words, this doesn’t have anything to do with anything” (“Gary”, April 2010).

These tensions between my roles as a researcher and explorer have been an important directing factor behind the autoethnographic components of the research. It also points to the distinction between experience and representation reinforced by my project participants through their work. Urban exploration, despite claims by outside observers (High and Lewis, 2007, Bennett, 2011), is not a

---

<sup>8</sup> There are about 10,000 registered users according to Davenport (2011) and Otter suggests there are probably about 3000 active in the UK (Otter, interview, October 2011).

spectator sport and the beautiful long-exposure photographs urban explorers are becoming famous for, as Silent Motion told me, “exist solely as markers to experience” even as they are, as Winch extolls, “proof of what we’ve accomplished” (Silent Motion and Winch, December 2009).

### **Demographics**

This is not a quantitative study about involvement and I will not begin enumerating participatory statistics beyond what I have done above. However, I have given a number of presentations about my research to various audiences and in almost every instance, a question is raised about the lack of equal female participation in the practice. This is obviously an important point to address (see cover photo). There is clear imbalance in the ratio of women to men involved in urban exploration (approximately 10%-15% of London explorers are female). While explorers themselves have been accused of being sexist, probably due to the highly masculinised edge to the images they produce and obvious links to the male-dominated historical foundations of “exploration”, there is nothing explicit in the exclusion of female participation. Women who are involved tend to be very highly regarded. However, the determination within the community to valorise risk and push extremes certainly seems to appeal to a characteristically (at least historically) “masculine” way of seeing the world.

The issue then seems to be a more intangible one about the way the community has already formed (without any overt consensus), the root of the movement being founded upon an admittedly selfish desire to “take” what is wanted from the environment in terms of both pictures and experiences, as long as it hurts no one else – Siologen’s “victimless crime”. This is, again, pitched in terms of personal



responsibility, regardless of the illegalities or external concerns provoked by explorations. The resultant community atmosphere is almost nightmarish in its competitiveness, a mirror of the hacker's open source "completely" free market. Most women, and many men, find the atmosphere during meets (meetups) abhorrently masculine, fuelled by alcohol, fireworks and grand tales, though Winch contends this is just another aspect of freeing oneself from socially acceptable normative behaviour. As Siologen once said to me, "it's amazing there even is a community, given that urban exploration is a basically just groups of friends competing to do epic shit first" (Siologen, November 2010).

Despite this problematic imbalance, there were a number of women involved with this project including Hydra, Drainpipe, Claire-Elise, Urban Fox, Agent M, Shreen, Rookinella and Jess. Many more are involved with the practice outside of my research group including Nurse Payne and a famous Australian explorer who changed their gender from male to female. Dystopia, Dsrt Chck, Aurelie Curie and DarlinClem, added to this list, make up a formidable contingent of female explorers and are well respected in the community. Rookinella, for instance, is also an administrator on the *28 Days Later* forum. Connected to this, and despite there being a significant contingent of gay explorers (perhaps 10%), including the universally respected openly gay Futtslutt of Minneapolis, Thelma and Towanda,<sup>9</sup> there is a tangible homophobic element within some urban exploration groups. In the UK, it is rumoured that one of the first forums actively banned openly gay explorers as well as explorers from a number of minority groups. It is unlikely this would be tolerated in any explorer group today.

---

<sup>9</sup> <http://futtslutt.tumblr.com> (accessed 1st January 2012).

Perhaps due to stories like these, it has been suggested that urban explorers are all “white” and “middle class” (High and Lewis, 2007: 63). But here again the community is perhaps less homogenous than it appears on public web forums. While it *is* the case that this is a study about a group of mostly white, middle class men (similar to the work of Willis and Jefferson, 1990 on “hippie” culture) where Yaz once told me (half joking) that he was “the wrong colour to be an explorer”, there are people from a wide swath of nationality, economic background and vocation involved in the London urban exploration community, though the community is overwhelmingly Caucasian, likely because of fear of police overreaction if, for instance, someone of Middle-Eastern background were caught exploring infrastructure.

My project participants include individuals from the UK, USA, Sweden, France, Australia, Italy, Belgium and the Netherlands and include a number of people with various office jobs, a social housing worker, a manager at ASDA, a bus driver, a church leader, an exotic dancer, photography, film and music students, an owner of a construction company, a few freelance photographers, a joiner, a banker, a call centre worker, a lighting engineer, a supermarket worker, a special constable, a dentist, a geography teacher and, unsurprisingly, a number of people working in software, IT and web design industries who might also be considered “hackers” in a virtual sense. Stunningly, all of my project participants are employed full time or in school and despite perhaps perceiving of their day jobs as “boring” or pointless, many express militant opposition toward anyone seen to be “leaching” off of the system, again connected to the personal responsibility ideology. Olstead (2011: 4, following Fletcher, 2008) offers another rationale for the demographic in her work

with “professional” females who participate in dangerous sports where she writes that,

...class differences in rates of participation do not simply reflect structural inequalities... risk sports have particular appeal to the “professional middle class” because of the way in these activities both satisfy and provide escape from a class culture, which requires continual deferral of gratification and self discipline.

Similar to Olstead’s research, there are very few people involved in urban exploration that are economically destitute, even if many work “minimum wage” jobs. Obviously, in order to have the opportunity for these sorts of engagements with the city, one must be secure enough financially and have enough free time that investing the hours necessary to research and explore sites can be accomplished. One also, more importantly, has to view these spaces as primarily areas for play and creative practice rather than potential housing for instance (see video 10, *Crack the Surface*, 6:35). As we found in our exploration of economically disadvantaged areas in Poland and the drains of Las Vegas (O’Brien, 2007), our relative affluence became readily apparent when we explored places only to find people living in them. In this excerpt from my field notes during a road trip to Poland to explore abandoned Soviet military sites, I logged these thoughts,

*The further East we went, the heavier our bourgeois baggage became. As we crossed the border into Poland, the car was filled with excited cheers quickly followed by confused murmurs. While the landscape here offered what we have come to expect from Europe – endless ruins – we found ourselves confronted with a place in which the relationship to derelict space was entirely different.*

*Here ruins were spaces not of bounded exclusion but of potential utilization. After driving for hours through a forest hunting for a soviet base called Keszowca Lesla, we arrived at 10pm to find rows of buildings, clearly Soviet-built, surrounding an undecipherable war memorial that looked like our standard Eastern European fare with the addition of satellite dishes hanging off the sides of buildings. It seemed the local population here had turned this place into a summer holiday encampment after the collapse of the USSR and the abandonment of the base. Gangs of teenagers roamed the streets late at night in tracksuits and mullets, running in and out of the derelict buildings and bunkers.*

*Inhabited buildings looked derelict. There were no fences or security to be found, no rules, boundaries or exclusionary practices in evidence. It should have been paradise for us. Except that things felt different here.*

*And then the difference hit me - there wasn't a hint of nostalgia to be found. No one cared about stripping soviet blocks of all they were worth because they were still in pain here. It was probably, rather, a delicious catharsis to smash out those windows and excavate the rusting hunks of artillery from the ground to sell to scrap yards.*

*There was a particular guilt that came with exploring Poland. I think that guilt came from the clashing of different value systems in regards to derelict space. Perhaps it is an indication of a larger clash between capitalism and communism. Where east meets west, desire meets utility, nostalgia meets future promise and mobility meets placemaking. We all knew we brought the West with us and we all knew, deep down, that the social conditioning that resides in those templates can never be completely erased, much as we try (Field Notes, August 2010).*

It is only in the context of exploring the cities in which they are comfortable that urban explorers can make the sorts of claims to space they do. As Winch said during that trip, on our way out of Poland, "I felt just as likely to get my ass kicked and camera stolen out there than get a good photograph... and I couldn't blame them" (Winch, August 2010). It is important to point out however that not every urban exploration crew would be willing to undertake the sorts of trips that would cause you to question motivations behind the practice. This is the reason I stayed close to the people I did in the first place.

Taken at a metropolitan level, the urban exploration "community" is pretty loosely structured. The group that I work with might be considered what the sociologist Charles Horton Cooley called a social "Primary Group" where he defined them as,

*...characterized by intimate face-to-face association and cooperation. They are primary in several senses, but chiefly in that they are fundamental in forming the social nature and ideals of the individual (Cooley, 1909: 23 cited in Anderson, 1976: 33).*



Figure 12. An encampment found in a derelict Soviet military base in the forest, Germany, photo by author

The larger global urban exploration “community” is beyond what Anderson (1976) would have termed an “extended primary group” in his work in the 1970s on a Chicago street corner. The connections in this community are much more tenuous, competitive and contested. However, despite internal claims to the contrary by practitioners who claim they “have nothing to do with other crews” (Patch, Interview, December 2011), there clearly *is* an urban exploration community. Although explorers, on some level, insist on the right to individual affirmation of personal subjectivity through unregulated existential action, self-concept and identity are of course also products of collective action (Mead, 1934) and we often communicated, traded information and visited explorers in other cities (Minneapolis, New York, Brescia, Stockholm, Paris and Moscow among others).

At its largest scale, we might imagine the international online UE community, remotely connected by UER, the world’s largest web forum. Within Britain, we

then find a range of groups loosely arranged around the forums *28 Days Later*, *Dark Places*, *Urbex Forums*, *Derelict Places*, *Talk Urbex*, and a few others, including private forums. Within London however, the community structure was rather unique, essentially four different yet overlapping crews operated in the city when I began my research in 2008 and many explorers were not connected to any particular group. Most of the London “Teams” operated outside of the forums or on secret forums that were by personal invite only.

Within six months of my initial involvement in the scene, I was solidly exploring with a group flippantly referred to as “Team B” by Oxygen Thief (implying our inferiority to “Team A” explorers), who became my primary group, project participants and collaborators operating first on a now-defunct forum called *Footprints in the Dust*, later whittled down into the 20-person secret (invite-only, non-search engine indexed) forum *Urban Infiltration Scene*. Eventually, as the reader will see as these stories unfold, these designations began to partially collapse and things became much more consolidated within the city by the end of 2011.

### **Style and research structure**

Throughout this thesis, I refer to the urban explorers who have been involved with my research by their known (public) aliases. At times, at their request, I have used double blind aliases. Although I have met over 100 people during the course of my PhD, the ones I have explored with most will reappear frequently. These individuals are Vanishing Days, LutEx, MC Nebula (or Neb), Statler, Winch, “Gary”, Patch, Hydra, Silent Motion, Marc Explo, and Otter. Less frequent explorations took place with Gigi, Yaz, Snappel, Claire-Elise, Siologen, Olivier, Kat, User Scott, Dsankt,

Furtle, River Monkey, Tigger and other explorers from Milan to Los Angeles (see Appendix A for my snowball sample meeting chart).

With each of these individuals from my primary group, I have collected photographs, video footage, field notes and diary entries. I have also collected direct quotes from emails, facebook messages, text messages, forum postings and blog postings. Everything that I quote or paraphrased from my primary group has been vetted through the community and approved for publication. Some of what we did together will not be written about. Other explorations undertaken have had names omitted or small details changed at the request of my project participants for reasons that will be clear by the end of the thesis.

In 2001, Ian Cook and Mike Crang noted that “while it is often commented that geography is a visual discipline, there has been little attempt to move from text-based dissertations, theses and even methods books” (Crang and Cook, 2007: 119). The thesis is an attempt to take that call to arms quite seriously and is comprised of 75,000 words, 200 photographs and 10 short video pieces (all viewable at <http://vimeo.com/channels/placehacking> or on the DVDs in the back on this thesis), all utilised in distinct yet complementary ways (see Chapter 2 and Garrett, 2010b). As such, this thesis is meant to be read on the screen rather than on paper so that one can fully engage with the high resolution photographs, web links and high-definition video clips that make up the work. In short, this doctoral research output is a multimedia document.

Additionally, as a result of the way the research has been structured, the writing fluctuates between narrative form and conversational tone to quotes with typos

from internet sources to more polished “academic” components. Rather than finding this confusing or too disorienting, I hope the reader will enjoy those twists and turns. It is my intention that the resulting document exists as a vulnerable text (Behar, 1997) that reveals the fluidity, richness, spontaneity, difficulty and absolute starry-eyed wonder that undertaking the work has been, work that has changed myself and my project participants irrevocably (Ellis and Bochner, 2005). I make no pretence at objective ethnographic observation here, as the first person ever to do in-depth research with this community, I am well known by most urban explorers in the world now, respected and despised alike. I even, halfway through my research, received a politically motivated lifetime ban from the *28 Days Later* forum and weeks of hate mail for a breach of the mythical UE “code of ethics”, which I will return to in chapter 4.

In the rest of chapter 1, I begin by unpacking the term “urban exploration”, both its implications and praxes, and look at the popular history of the practice from within the community.

### **Situating urban exploration**

“UE is a crime but I won’t do time.”

– UE Kingz<sup>10</sup>

Despite the widespread public recognition and assumptive understanding of the term “urban exploration”, many urban explorers themselves reject the phrase. As Alan Rapp (2010: 11) has written, “like many emergent cultures, [urban exploration] has accrued a definition without centralized guidance or even consensus” which has led to ceaseless fracturing in those instances where communities are formed and endless disputes over the politics, ethics and

---

<sup>10</sup> *UE is a Crime*, <http://vimeo.com/15869889> (accessed 1st December 2010).



boundaries of the practice. A number of my project participants object first to the term “urban”, given that many of our explorations take place in distinctly rural areas. The sleepy coastal town (yet busy port) of Dover, for instance, is full of bunkers, mines and forts and we have made numerous trips there to explore them.



Figure 13. "Gary" exploring a bunker, Dover, photo by author

This notion is normally sidestepped by pointing out that urban exploration is defined by the exploration of human-built environs which “extend into the countryside as mines, dams and ghost towns [and] must be understood as part of the city’s structure” (McRae, 2008: 2). As Graham (2001: 11) has written, we might also understand the size of the city not in terms of its built structure (topographical) but in terms of its sphere of influence (topological). In short, “the city is everywhere and in everything” (Amin and Thrift, 2002: 1) through its global connectivity.

At the same time, the perceived dualities of the urban and rural, natural and human-made have been complicated by recent scholarship (Whatmore, 2002), reinforced by urban explorers themselves writing about the collapse of those boundaries within ruins where “...the most beautiful sights... are the result of natural processes left to operate on man-made materials, machinery, surfaces, furniture” (Roppo, ND: cover). Notwithstanding their shared public axiom of “take nothing but pictures and leave nothing but footprints”, these explorations remain distinct from wilderness exploration for their focus on the intentionally human-built environment and the most celebrated or “epic” explorations are usually, because of their difficulty in locating and gaining entry to, located in the most densely built-up urban areas.

Perhaps more problematically, the term “exploration” conjures up a host of imaginaries pulled from the cultural baggage the term carries around; visions of colonial expeditions, invasions, subjugated populations, disease and occupation (Johnston, 2000). It is language of conquest. Given the (I think mostly unintentional) exclusionary and relatively masculine nature of the practice outlined above, the use of the term becomes especially foreboding.

But here I would point to the reappropriation of the term by SI (Debord, 2006a) who made aimless urban wandering and pointless exploration for the sake of exploration into an alternative practice, set in the context of the urban everyday. I might also suggest the writings of radical geographer Bill Bunge (1969) who worked with local communities in the 1960s to explore areas important to them in the American Midwest. More recently, the wandering local narrative of Londoner Raphael Samuel (1994) also serves to bring exploration back to more Dickensian

roots, building narratives from the ground up through alternative explorations of areas of everyday experience (Harrison, 2000). Finally, we might look to Driver and Jones (2009) who have worked on hidden histories of exploration, getting behind the scene to relocate and celebrate those individuals who have been largely excluded from those narratives. All of this work points to what I would argue is a post-colonial populist reimagining of exploration.

The explorer and journalist Matthew O'Brien, author of the book *Beneath the Neon: Life and Death in the Tunnels of Las Vegas* spent two years interviewing homeless people living in storm drains under the city as he explored the entirety of the system (O'Brien, 2007). He now runs a non-profit organization called Shine a Light,<sup>11</sup> devoted to helping the homeless community in the tunnels. Urban explorer Steve Duncan has done similar work along with National Public Radio (NPR) in the occupied abandoned train tunnels of New York (Lynden, 2011 also see Toth 1993).<sup>12</sup> And in Italy, a crew called the Associazione Brescia Underground have legitimized their explorations and now run formal tours of the sewer system.<sup>13</sup>

Although these projects may not release the notion of "exploration" from that historical baggage, I contend that they do at least break up the epistemological bounding of the term enough to warrant a re-assessment. In the end, when I asked "Gary" if he objected to the term, he told me, "call it whatever you want, you still don't know what it is until you do it" ("Gary" August 2010). "Gary" could not be more correct, Crang and Cook support his assertion when they write "there is a danger of reifying categories until they become what the exercise is about" (Crang

---

<sup>11</sup> <http://www.beneaththeneon.com/shine-a-light.asp> (accessed 12 November 2011).

<sup>12</sup> <http://www.npr.org/2011/01/02/132482428/into-the-tunnels-exploring-the-underside-of-nyc> (accessed 12 November 2011).

<sup>13</sup> <http://www.bresciaunderground.com> (accessed 12 November 2011).

and Cook, 2007: 148). As a result, I am content to present this research as a scholarship of evocation rather than definition (Solnit, 2001), and to move into unpacking the practice without attempting to define and bound it to a great degree. The urban exploration community, again like hackers, have “a cultural sensibility that, in practice, is under constant negotiation and reformulation and replete with points of contention” (Coleman and Golub, 2008: 255). And so, frustrating as people may find it, urban exploration will remain a term under constant contention.<sup>14</sup>

### **Formally informal - urban exploration as practice**

“Ain’t nothing to it but to do it. I say it’s time for *action!*”

– (Marc Explo, staring up at the Heron Tower in the City of London)

Recreational trespassing surely extends as far back as notions of spatial ownership, though many of those stories will have been lost to time. Troy Paiva writes “urban exploration is a pastime as old as mankind. It’s simply how we’re wired” (Paiva and Manaugh, 2008: 9). One of the earliest stories urban explorers like to recount comes from 1793 when a Frenchman named Philibert Aspairt journeyed by candlelight into the abandoned quarry system underneath Paris (colloquially, and erroneously, known as the Paris Catacombs) looking for a “lost” wine cellar. His body was found 11 years later and a monument erected to his memory. Over 100 years after that event, one week after the opening of the New York subway system, Leidschmudel Dreispul was killed by a train while exploring the freshly-carved subterranean tunnels (Ninjalicious, 2005). Of course, not all tales have such tragic endings.

---

<sup>14</sup> See <http://ltsquad.com/Blog/2011/06/07/ue-just-what-the-hell-is-it-anyway> for an argument by Control of the LTV Squad in New York City against my reification of urban explorers as a group (accessed June 16th 2011).

The stories of Livy exploring Rome's Cloaca Maxima sewer (Brick, 2009) and John Hollingshead's insistence that London "sewers have been fruitful in furnishing antiquarian and geological discoveries" (Hollingshead, 2009 [1862]: 453) reveal a long history of fascination with liminal urban spaces ripe for rediscovery. The writings of Walt Whitman, Charles Dickens (who first published Hollingshead's London sewer explorations in 1861), Baudelaire and many preceding artists and groups including the Dadaists, Surrealists and Situationists serve as inspirational figureheads for contemporary notions of the practice with their passion for discovering dangerous, precarious, incongruous and absurd urban spaces.



Figure 14. Winch crawling through the Paris "catacombs", photo by author

Facilitated by the Internet, the first generation of cohesive urban exploration groups coalesced in the 1970s-1990s. These groups were (and are) known as the Drainiacs and the Cave Clan in Australia, Diggers of the Underground Planet in Russia, the Jinx Crew and LTV Squad in New York City, the Cacophony Society in San Francisco, the Action Squad in Minneapolis, Angels of the Underground in Canada, the Berlin Underground Association in Germany and various "Cataphile"

groups in Paris, among others. However, as Winch pointed out to me during a field interview, “the whole idea of a larger urban exploration ‘community’ isn’t our reality anyway, it’s just friends hanging out with each other” (Winch, December 2010). This comment attests to the importance and vitality of the “primary group” in the practice – precisely the reason urban exploration can’t be studied adequately from a distance.

The first recorded large-scale internet-facilitated urban explorer “meet” was attended by about 30 individuals in Brooklyn in 2002, organized by the LTV Squad, a graffiti-crew-turned-urban-explorer-crew, followed by an even larger meet in Toronto, June 2004 where 65 people gathered to go exploring together. If there ever was a moment when a global “community” was formed, certainly the years 2000-2005 were a pivotal period. Given that Ninjalicious, the first person to pen a book on urban exploration, was also from Toronto, the largest web forum, the Urban Exploration Resource, is run from there, and the fact that the city has produced a steady stream of internationally-respected urban explorers, including Michael Cook (Manaugh, 2009), I think it is fair to say that Toronto may be the birthplace of the modern urban exploration movement (for a more in-depth look at the history of urban exploration, see Ninjalicious, 2005). However, despite the increasing size and national eclecticity of these continuing gatherings, many urban explorers, like Winch, still maintain that they are relatively unconcerned about the notion of a cohesive urban explorer community beyond their group of friends.

Following from Wershler-Henry’s assertion that urban exploration is a “postmodern version of Fodor’s [travel guide]” (2005 quoted in High and Lewis 2007: 42), I suggest that these public image fissures are exactly what urban

explorers want to present to “outsiders” despite their clear sense of community that exists (for instance, my project participants and I have over 100 “shared” friends on Facebook, all urban explorers from around the world). Urban explorers, like computer hacker groups such as Anonymous (Fantz and Shubert, 2010), perfectly understand that to transgress, to create a “movement” of resistance, is to create a target for authority to bear down on. The fragmented community that urban exploration is, nomadically operating under aliases and photos full of blurred faces, shifting identities and constantly changing geographic locales precludes the possibility of urban explorers constructing any grand narrative of opposition. Now this is not to say that it would actually be difficult to unravel the smokescreen, it’s admittedly a pretty thin ruse (see chapter 6) and perhaps this is where Wershler-Henry’s accusation really hits home. Urban explorers take these precautions less, I think, because of fear of persecution and more as a by-product of postmodern obsessions with being “beyond” labels. It is also, in a way, a cop out for having to articulate their motivations for what is, in the end, a largely selfish pursuit.

Explorers clearly enjoy the image of the urban explorer as miscreant or vandal masked up and sneaking into the city during the early hours, shatter illusions of security by demonstrating that these artifices can be breached by a group of 20 and 30-year olds after work every night (Osborn, 2011), even as graffiti artist, for instance, “clown” the practice as being pointless, suggesting explorers “go places and do nothing”.<sup>15</sup> Although the images urban explorers produce, including those in this thesis, can appear almost menacing, in reality, there is nothing very alarming about urban exploration, it is certainly more quirky than threatening.

---

<sup>15</sup> <http://thisismycostume.wordpress.com/2012/01/06/urban> (accessed 6th January 2011).

Exploring places rarely leaves the city vulnerable, what the practice *does* challenge is the underlying message of constant and immanent threat promised by late capitalism used to codify the urban environment for our “safety” and restrict the range of acceptable activities. Exploration of “secure” sites reveals this spectacle to be, similar to explorers’ public image, a smokescreen. As an anti-spectacle (Pinder, 2000), I would venture to guess that most explorers hope that their narrative is found to be the more tantalising option and pulls people away from the mall and television screen (I will return to this notion of anti-spectacle in chapter 4). In this way, urban explorers undermine “clean” narratives. While urban exploration is clearly not something many people might want to be involved with, most explorers appreciate and often take part in other urban subversions like graffiti, parkour and skateboarding and expect reciprocal respect on some level.

Urban exploration, in its entanglements with urban history, is similarly organized to undermine any grand narrative in relation to encounters with the past (see Chapter 3 and Garrett, 2011a). The movement, importantly, seeks to re-localize experience, to make memory, community and friendship personal (created and maintained within the primary group) in instances where it is felt these relationships have been eroded, though it is important to note, again, that urban explorer’s response to this situation is not to blame the system but to do what they wish, regardless of the system.

On the website of Dsankt, one of the most well-known urban explorers in the world, the bar at the bottom of the page that would normally say something to the effect of “Don’t try this at home” instead says “Disclaimer? There is none, do as you



wish. Climb bridges, run the subways, play in sewage, go in drains.”<sup>16</sup> The message behind the disclaimer is clear – no one is stopping you from doing this but yourself. And perhaps this is where the postmodern fractures between preceding connected practices become more evident. Unlike, for instance, the SI, urban explorers aren’t calling for a revolution, they just want to inspire an awakening that will encourage people to viscerally engage with the world, in whatever way strikes them, as most people did when they were children, to contribute to the creation of a more ludic city (Stevens, 2007).

Perhaps the most striking distinction between the SI or praxes rooted in Marxist thought is that urban explorers clearly enjoy capital materialism for its inevitable surplus and superfluous nature (Doel, 2009). Where Marxist scholars and practitioners in particular work “against the forces of development” (Pinder, 2000: 368), urban subversionists such as *traceurs* and *traceuse* (parkour practitioners) (Mould, 2009), street artists (Dickens, 2010), base jumpers and urban explorers work within the spectacle (since there is no longer an “outside” of the spectacle), playfully entangling, unravelling and enjoying the products of capital in new and novel ways. As the explorer Spungletrumpet said to me, “[urban exploration] can't possibly be over until they stop building stuff” (Spungletrumpet, July 2010). These playful infiltrations are then, many times, put on public display to the dismay and sometimes embarrassment of developers, as when recently explorers snuck into the under-construction London 2012 Olympic stadium by cover of darkness, photographed it, and posted it online, resulting in an internal security uproar even

---

<sup>16</sup> <http://www.sleepycity.net> (accessed 1st December 2010).

as the public found it quite amusing to see the barriers of that seemingly impenetrable monolith to nationalism and “security” breached on explorer blogs.<sup>17</sup>

Unlike political movements built in resistance to capitalism, urban exploration is not an attempt to build a “new” grand narrative of resistance but to subversively reimagine what already exists, undermining to some extent, but more importantly complicating, urban identity and imagination through a playful exchange with waste and excess (Hawkins and Muecke, 2003). Graffiti writers, like urban explorers, do not tend to get involved in discussions about what should be preserved, regulated and/or constructed, they simply assert that “everywhere is free space” (Cresswell, 1996: 47).

One of these archetypal “free spaces” (re)located by explorers is, as Tim Edensor has written about extensively (Edensor, 2005c, Edensor, 2005a, Edensor, 2005b, Edensor, 2007), derelict space where, once past a many times well-secured boundary zone, freedom of expression is relatively unregulated by social expectations. For an example of this, I turn to an excerpt from my ethnographic field notes, when I accompanied Hydra on an exploration of Battersea Power Station, our first time into a site which has since become a place of serial trespass in London,

*We were hiding in the bushes, covered in mud, watching the security patrol walk past on their rounds. I could hear the gravel crunching under their boots and their conversation about a football match. Beyond them, Battersea Power Station sat empty with its beautifully grim brick walls and creamy smoke stacks jutting into the slow clouds. Security turned the corner and without a word we ran, crouched low. Over the fences we went, two to get into the courtyard, one more to get into the walkway entrance. The last fence was broken and made an incredible amount of noise as we tried to get over it. We held the fence for each*

---

<sup>17</sup> <http://www.silentuk.com/?p=1216> [accessed 3rd December 2010].

*other, sweating and shaking, got over quickly (if not quietly) and ran into the roofless central hall, falling into the grass, trying to suppress our laughter and excitement.*

*Lying there, catching our breath, staring up at the massive chimneys we would soon climb, inside one of the most iconic (yet derelict) sites of London, I felt an immense sense of freedom. Hydra turned to me and said “should we go see what else we can find in here?” and I felt the tension release from my shoulders. I knew that I was in love with this, I never want this feeling to leave me (Field notes, May 2009, Battersea Power Station, London, UK).*



Figure 15. Silent Motion on a Battersea Power Station chimney, London, photo by author

Battersea Power Station, along with Millennium Mills, are considered by the urban exploration community to be the last great industrial ruins of London and, as such, have taken on an almost mythological status. When explorers from other cities visited our crew in London, both of these places were usually on the “list of attractions”. However, the stories I will tell of my time with the Consolidation Crew will reveal a world that goes far beyond the “ruin exploration” depicted in almost all contemporary writing about urban exploration (Rapp, 2010, McRae, 2008, Lipman, 2004, Douglas-Jones, Harris, 2010, Deyo and Leibowitz, Edensor, 2005b,

High and Lewis, 2007, Trigg, 2006, Dobraszcyk, 2010, Garrett, 2010a) and goes into the city (quite literally) in ways which the reader may find terrifying as well as inspiring. I will argue that this worked to bring urban exploration back to its roots in live infiltration (Ninjalicious, 2005) and hacking.

As the reader may have surmised by this point, this thesis will offer no easy narrative or central defining theory. Like the practice of urban exploration itself, the research sidesteps being easily labelled as explicitly “qualitative”, “Marxist” or even “ethnographic”, because real life practices can’t be delineated according to singular ontological characterisations. Additionally, in an ethnography driven by multiple individuals in varying circumstances, making a claim to a central theoretical motivation or principle would ultimately prove facile and likely frustrate the people who have invested in me to convey these stories in their full depth.

If anything, the research has been more method driven than theory driven and I may, as a result, rely too heavily of those visual methods utilized (see chapter 2) in an effort to stay “close” to my participants who also rely heavily on those visual skills as a way of communicating experiences which are largely inarticulable. Despite my necessary criticisms and challenges to the community, I, in the end, learned far more from my project participants than I ever could have imagined. I certainly didn’t do the ethnography I set out to do and, in the end, my ethnographic method was defined not as researcher/subject but through the eyes of friendships only forged through deeply shared experiences over long periods of time.

In the next chapter, I turn to my methods to discuss the ways in which they succeeded and failed, preparing us for the tales of urban exploration that will be unveiled through the rest of the thesis. In chapter 3, we will turn to look at the departure point for most urban exploration – that of ruin exploration – to think about the ways in which the practice encourages complex temporal emotional entanglements in places (building on the groundbreaking work of Edensor, 2005b). In chapter 4 we will look at the ways in which my work with “Team B” and the “London Consolidation Crew” increasingly turned to infrastructural infiltration, thinking about how explorations of the vertical and hidden city through calculated risk taking “edgework” in the practice work to change perceptions about what constitutes the city. In chapter 5, I will discuss embodied experiences of exploration, yearnings to play with emotions and desires in unlikely places to tap into the sensory surreal. In the final chapter, I will discuss the ways in which all of these aspect of the practice are coalescing into a deepening spatial politic that is receiving increasing attention and make some predictions about the future of urban exploration, including the wider implications I think its emergence, growth and inevitable continued fracturisation have for reconfiguring (especially urban) geographical theory and endeavour.



Figure 16. "Gary" at Spillers Millennium Mills, London, photo by author

## Chapter 2 – Methodological frameworks

### Doing visual (auto)ethnography

“There is only one way to understand another culture. *Living* it.”  
– (Høeg, 2005: 169 italics original).

Over the past three years, I have conducted a deep ethnography with the London urban exploration community through a variation of snowball sampling or respondent-driven sampling (Salganik and Heckathorn, 2004, Cassell, 1988, see Appendix A), building a research group that now includes over 100 project participants. My primary ethnographic group was “London Team B”, a group of about a dozen explorers, one of the most active in the city between 2008 and 2011 and part of what might be considered the 2<sup>nd</sup> generation of the London exploration “scene”, though it’s important to keep in mind I largely label the group for analytical convenience, group formation and continued involvement was and is, for the most part, constantly in flux.

Ethnography, as practiced by most geographers (Western, 1997, McDowell, 1997, Laurier, 2010, Butler, 2003, Degen and Desilvey, 2008), often has more brief “ethnographic contact” components, with most of the work residing in detailed analysis of the records created during those encounters. As Söderström (2010) writes, this may have to do with the intense development of spatial analysis within geography from the 1950s to 1970s. Söderström explains that David Ley, when he proposed to do fieldwork in inner-city Philadelphia in the 1970s (Ley, 1974), had a very hard time convincing faculty members in the department of the need to go “out there”. This tendency toward “virtual” fieldwork has of course been assisted by the rapid growth of the Internet.



Figure 17. The author with Team B, early 2010, Temple Court, London, photo by author

Many geographic ethnography projects are driven by a range of “qualitative methods” including, on a broad scale, “data collection” (Rowles and Watkins, 1993: 517) and “field visits”, down to “large scale questionnaire survey[s] and “nested hierarchical sampling method[s]” (McDowell, 1998: 2136). These studies were and are valuable. However, while this sort of work utilizes ethnographic methods, the researchers often retain an “outsider” status and do not usually give direct voice or editorial control to the researched. More qualitative ethnographic work has been done within geography which has attempted to “go deeper” by Sibley (1981) working with Gypsies, Western (1997) working in apartheid Cape Town and Parr (2000) doing covert work about treatment of the mentally ill in Nottingham. These were inspirational case studies.



The work Mike Crang conducted with historical re-enactors and Ian Cook in his research on a Papaya farm (Crang and Cook, 2007) were also important templates for my research. In both cases, Crang and Cook were both observers *and* participants. Additionally, the ethnographic work of Sarah Cant on caving culture, where she participated on a number of trips and gave project participants plenty of “speaking space” (Cant, 2003) was also an inspiration and this project builds on that tradition of “deep ethnography” within the discipline. I have spend the better part of three years living and working with my project participants on an almost daily basis and co-authoring popular work with them (see video 10 – *Crack the Surface* and video 8 – *Sewer Skank*) which has received international recognition.<sup>18</sup> I also gave them editorial control over my representations of them in this document (and related publications) as much as possible without giving up my own voice.

The goal of this project was to push geographic ethnography even further, to do what futurist Justin Pickard has referred to as “Gonzo ethnography” where the ethnographer groks the subject; comprehending (relating intellectually) apprehending (relating emotionally and spiritually) the quiddity, essence, and being of a thing, event or being.<sup>19</sup> I sought to completely collapse my identity into the group, to become the researched as sociologist Elijah Anderson did at Jelly’s Bar in *Our Place on the Corner* (Anderson, 1976), to write from a life of direct experience as Applebaum (1981) has in the context of the social lives of construction workers. In these instances the ethnographer goes beyond the participant/observer relationship to becoming an active producer and reproducer

---

<sup>18</sup> We also undertook collaborative blog postings such as <http://www.placehacking.co.uk/2011/04/24/security-breach-london-mail-rail> (accessed 15th July 2011)

<sup>19</sup> Justin Pickard’s blog can be found at <http://justinpickard.net> (accessed 15th July 2011).

of the culture under study. In effect, over the course of my research I rendered myself invisible in the study group as a researcher, regardless of my constant assertions I was “writing a book” or “making a film” about “us”. At the same time, I tried to keep in frame my autoethnographic or “reflexive” (Cant and Sharma, 1998) role, aware of the points at which I was perhaps overstepping. Of course, fieldwork never goes that smoothly and those vulnerable moments that bear the reality behind research this deep are, I hope, embarrassingly evident.



Figure 18. Statler, "Gary" and the author at the Soviet base *Vogelsang*, Germany, photo by Winch

This project, in the end, takes a significant ethnographic lead from the Chicago School of Sociology. As Elijah Anderson writes “At the University of Chicago in the 1920s and 1930s, Robert E. Park encouraged his students to ‘get their hands dirty in real research’ by engaging in fieldwork among taxi dancers, hotel clerks, youth gangs, the residents of ‘immigrant colonies’, hobos, and the well-to-do” (Anderson, 2009b: 371). The work of the Chicago School (and the 2<sup>nd</sup> Chicago school, post World War II, of which Anderson is a part) redefined what “deep ethnography”

which accumulates a store of “local knowledge” (Geertz, 1983) looked like. Sometimes, as in Agar’s 1973 study of Heroin Addicts (Agar, 1973) it looks frightening or illegal. Sometimes, it just looked boring (if necessary) (Schneider, 1980). What it always strove to be though was an indissoluble fusion of the researcher and the researched (for a fantastic collection of urban ethnography from the “new” Chicago School see Anderson, 2009a). This research is a reminder of the continued importance for researchers to “get their hands dirty”.<sup>20</sup>

In terms of methodological technicalities, many of these earlier ethnographic projects use one “method” of recording, usually text, video or audio. Video and audio, where they are used, are most often transcribed into text. Visual ethnographer Sarah Pink defines ethnography as “an approach to experiencing, interpreting and representing culture” (Pink, 2007: 18), making every ethnography an autoethnography to an extent. Through my shared experiences with this group, I have also myself become an urban explorer, now socially embedded in this transnational enthusiasm focused on exploring and recording informal spaces (Hudson, 2010), derelict places (Edensor, 2005b) and hidden infrastructure (Graham and Marvin, 2001). As a result, I am implicated everywhere in this work. As Pamela Shurmer-Smith notes, “ethnographic work should change the researcher” (Bennett and Shurmer-Smith, 2001: 260) and there is no doubt I am not the person I was when I began this research. By the end of the thesis, as you will see, the UK urban exploration community would also never be the same after what we did as a group and my need to publish our work together was a point of contention more than once.

---

<sup>20</sup> In terms of experimental ethnography, a post on the Anthropology blog Savage Minds posited that the HBO Series *The Wire* was the best modern ethnographic text in the United States today: <http://savageminds.org/2008/02/25/is-the-wire-our-best-ethnographic-text-on-the-us-today> (accessed 16th June 2011).

As I have shown in this section, although ethnography is a recognized methodology in geography, sociology and anthropology, the ways in which we do ethnographies may vary greatly (Crang and Cook, 2007). Focussing in now, I will suggest conceptualizing the following section at the intersection between what Crang and Cook (2007: 167) term “autoethnography” and what Sarah Pink calls “video ethnography”. This thesis is therefore, maybe slightly more broadly, a multimedia autoethnography.

### **Autoethnography**

Although the term autoethnography invokes almost reflexive fears of solipsism (Pile and Thrift, 1995), I feel it necessary to, at least minimally, render my positionality transparent as a component of my method, given that my research is, at least potentially, about a spatial politic. But my need to recognize my own political, cultural, social, ontological and epistemological foundations also extends to my blatant recognition that I, though the course of my ethnography, became invested in this community and intentionally threaded myself into the practice as a subcultural producer and promoter. More to the point, I am complicit in assisting Team B’s rise to international recognition, primarily through my website [www.placehacking.co.uk](http://www.placehacking.co.uk) and secondarily through documentary film production (Garrett, 2010a) and academic publications such as articles in academic journals (Garrett, 2010a, Garrett, 2011a, Garrett, 2011b, Garrett, 2011c).

In short, I went native. What I am going to argue is that there is value in that. Doing an ethnography of a subculture or a culture close to the researchers, especially speaking the same language, allows one to perhaps do a “deeper” ethnography

with the counterbalanced loss of some potential objectivity or etic perspective (Harris, 1976). I contend that the ethnographic (im)balance I was able to achieve on this project had more strengths than weaknesses. As I will show, my background was similar enough that I was able to gain acceptance into a very closed community and different enough that they found my presence there interesting and (I am sure at times also amusing) as a “foreigner” and public provocateur. Given that ethnographies are “as much about the culture of the student as they are of the studied” (Herbert, 2000: 563), I think it is important to briefly outline my background.

I grew up in Southern California in a violent (at the time) desert suburb of Los Angeles on the cusp of gentrification. My childhood was filled with subversive activities including skateboarding, building illegal low-rider vehicles and running a video game pirating business. I came from a middle class family (in an American sense) with English and German origins wealthy enough to allow for these hobbies and pastimes but not wealthy enough to pay for college in full. At 19, I opened a skateboard shop in Riverside, California, which I then sold to my partner two years later to begin my university education.

While my background was similar to many of the explorers I would eventually meet, I knew nothing about urban exploration when I began my PhD in 2008. My position as a PhD student was an anomaly in the community and my lack of what was seen as “gainful employment” earned me much ridicule from explorers who told me I was “scamming the system”. Otter went so far as to say I was “wasting our fucking taxes on bullshit writing” (Otter, January 2011). Marc Explo once also told me that “I might as well be on welfare since I don’t have a real job” (Marc

Explo, September 2010). My best defence was claiming an active complacency in the “scam” I was running on the system – essentially I was the only person being paid to explore. I was both respected and resented for this.

The problems in becoming an “insider” were rife from the beginning. I came to the community as a filmmaker (after doing viewer-created content work for Current TV in San Francisco) with no experience in photography, the primary medium of the practice. This was initially treated with great suspicion. I began on the world’s largest web forum, UER,<sup>21</sup> by posting the following message:

*I am a filmmaker and PhD student in London looking for urban explorers, adventurers and infiltrators to go for some crawls through derelict spots in London.*

*I have a spot we can explore, but I will come to you anywhere the Tube [London Underground] goes. I would prefer groups of two or more going out before Dec. 8th. I will be back again Jan 1st if that does not work.*

*Basically I want to get footage of exploration and do some 'in the field' ethnographic interviews about the motivation to explore in the city.*

*Participation will get you:*

- 1. On TV where 10 million viewers will learn about what you do*
- 2. In an article for the journal Geography Compass*
- 3. Talked about at conferences all over the world*
- 4. In my Ph.D. dissertation with some props for being cool enough to invite a noob*
- 5. An insiders look at my favorite location in Wandsworth (pictured)*
- 5. To help me advance my career and inflate my ego*

*If you are interested, email me at [b.garrett@rhul.ac.uk](mailto:b.garrett@rhul.ac.uk) and I will give you more details.<sup>22</sup>*

The response was incredulous. Alias wrote back “your location in Wandsworth looks awfull. I will do the documentary if u show me a photo of you stood on top of Battersea Power station.” Siologen then responded by saying “Given theres just

<sup>21</sup> <http://www.uer.ca> (accessed 19 July 2011).

<sup>22</sup> This message was posted on 17<sup>th</sup> Nov 2008. The thread can be viewed at [http://www.uer.ca/forum\\_showthread\\_archive.asp?fid=1&threadid=61723&currpage=1&pp#post18](http://www.uer.ca/forum_showthread_archive.asp?fid=1&threadid=61723&currpage=1&pp#post18) (accessed 19 July 2011).

been two articles portraying exploration and draining a negative light on the BBC, this seems kinda sus [suspect].” Jondoe wrote back “Point 1. of the *Participation will get you* list is more likely to discourage. I’m sure someone will offer a hand though . . . :/” and finally Otter, one of my primary project participants two years later, wrote back with a scathing “Jesus talk about a guy who clearly HASNT done his research”.



Figure 19. Kops brewery, the first location the author explored in the city, London, photo by author

I now realise that this vetting process of “trolling” new forum members and potential exploring partners (noobs) is an important part of culling those who are not wholly committed or who may portray the community in a negative light, therefore irreparably damaging the credibility of whoever invited them in the first place and potentially exposing the dirty secrets of a community built on exposing secrets, an embarrassing irony. However, as Coleman and Golub (2008) write

about underground hacker communities, though they may difficult to enter, once you are offered friendship you are quickly taken in, shown secrets, supported (even when wrong) and not expected to leave. In many ways, the organisation of urban explorer groups mirrors hackers which “mirror those of street gangs, where the talk is of respect, attacks, who can be trusted, who the enemies are (usually law enforcement and rival gangs), whose ground belongs to who, and who has accomplished what” (Arthur and Halliday, 2011: np).

Alias wrote me back in a private message later with a note that said “sorry for being a cunt on the forums, but I have a reputation to maintain you know” (Alias, November 2008, via private message). What may at a glance appear to be a community of ego-driven “keyboard warriors” is actually, like most things in urban exploration, a smoke screen. Behind those forums, there are groups of very close friends who are barraged almost weekly by media and students looking to do projects on “UrbEx” as well as police and security posing as explorers to gather information and get access details to locations so they can be sealed. I have found myself, three years after posting that first message, reacting in much the same way they did, amidst a constant barrage of various media requests with a heavily moralised edge and daily hits on my blog from the British Transport Police – again pointing to the importance, and indeed necessity, of insider knowledge and connections in this research.

### **Visual ethnography for a visual culture**

When I initially approached the community offering to do video work, I thought it would be seen as a valuable addition to the photography work already taking place in the community. When people in the community made it clear they were not





*doing exploration*" (July 2010). As Cook and Crang (2007: 112) write in relation to the work of anthropologist Sol Worth "film (and photography) is not so much about what is 'out there' and what is 'in here'" (Worth, 1981) and while my project participants exhibited carefully staged photographs of themselves, I attempted to reveal motivations and involvement in addition well as carefully staged experiential representations.



Figure 21. Camera nerds: Vanishing Days, Marc Explo and author, Hawkhurst Mansion, Kent, photo by author

While I eventually did begin taking more "traditional" exploration photos consisting of long exposures on manual settings, posed backlit people shots and decaying architecture, a difference in my photographic practice always remained which sometimes reminded participants I was documenting them as well as the places we visited. As an example, to return to the end of our 2-week road trip to Poland, Winch, Statler, "Gary" and myself found ourselves perched over a ventilation shaft with a straight 30 meter drop in Antwerp, Belgium at 3am

securing ropes to abseil into the never-completed Antwerp metro system. Winch, as he was threading loops and clipping carabineers, looked straight at me and said “will you put down that camera and help us with these ropes mate?” Never had my outsider status been so evident while acting as an ethnographic photographer.



Figure 22. "Gary" and Winch tying off ropes to drop into the Pre-metro, Antwerp, photo by author

Despite my preference for video, I cannot underemphasize the importance of the role photography played on this project. I took over 12,000 photographs as part of the research. As a result of my project participants teaching me photography over the course of my PhD, I am able to pull from multiple media for recall, video for images and audio as well as field notes for thoughts while shooting, creating a multimodal, multisensual, multimedia ethnography (Herbert, 2000: 563) intended to integrate more of the embodied experience of the research process into the final product. The project also, unintentionally, became a participatory video project. Although I am reluctant to call this a “visual ethnography”, I felt compelled to create a document constructed of text, photos and video because that is a

reflection of what this ethnography has been from beginning to end. Given that the form of this thesis is somewhat unique, I would like to, in the rest of this section, put forth my argument for the value multimedia ethnography.

Geography's relationship with the visual (to begin, see Driver, 2003, Rose, 2003, Rogoff, 2000) is something that has been written about at great length in other places and through one turn or another, despite apparent fears of ocular-centrism (Macpherson, 2005) photography has become an accepted, if not yet celebrated, geographic method. Photography is now practiced in numerous forms including photography as experiential record, participant portrait photography, architectural photography, archival analysis and photo elicitation, with geographers showing little reluctance to *become* photographers in the course of work on their projects. But even "visual geographers" seem to harbour some reservations about photography's ability to be singularly situated as a method, usually viewing it as supplementary to text. This thesis, though it is primarily a textual document, is comprised of photographs and video as well, as I feel they each tell components of this story in unique and complimentary ways.

Rose, perhaps the most well-known visual geographer, has written that even if we choose to use visual methods in our work, text must be our primary medium (Rose, 2001: 250). This argument has also been made by anthropologists who see text as necessary to "elucidate" videographic production (Hastrup, 1992, Heider, 1976: 127, Fuchs, 1988: 223). Visual anthropologist Sarah Pink, on the other hand, argues that "while images should not necessarily replace words as the dominant mode of research or representation, they should be regarded as an equally meaningful element of ethnographic work" (Pink, 2007: 4-5). As Mike Crang writes

in *Cultural Geographies*, “literature is... just one creative ‘media’ through which cultural ideas are produced and reproduced” (Crang, 1998: 81).

Raw fieldwork video footage serves as an excellent record keeper and a well considered, well shot, well edited video becomes a rich web of thought, memory, materiality and movement; a place making process “situated in the interstices between the collage of material articulations that encompass our everyday lives and ourselves” (Witmore, 2005: 58). The photographs of our experiences serve, as Silent Motion said, as bookmarkers to our experiences together, small points of memorial constellation and recall. The textual stories of our journeys together live on blogs, forums and fragments of Facebook wall postings and email exchanges, comments on photos and in private diaries. These media are complementarily inseparable.

As Sarah Pink argues convincingly, there is some case to be made for obtaining as many forms of record as possible, as she did on a walking tour of a Cittàslow town, collecting “multi-sensorial and multi-modal experience... represented with different intensity in different media” (Pink, 2008: 190). One argument for the use of video in these cases might be the potential for sharing your work with participants who may have interest in recordings for their own personal archives. Footage or photos held in the researcher’s archive can be grazed for virtual artefacts and visual heritage, long after the production is complete, by either yourself or your project participants (Omori, 1988). Winch, late in my ethnography, wrote on my Facebook wall “been reading some of the old stuff on Placehacking, and damn, the memories are fantastic” (Winch, Facebook post, June 2011)!

Playing into the idea of the urban explorer as preservationist, many times video footage and photographs serve as an (often unintentional) record of a particular time and place, preserving visually, aurally and sensually what will inevitably change, such as (in a more “public” sense) footage from inside the New York World Trade Center while the towers still stood or of London’s Borough of Hackney prior to the 2012 Olympic Park construction (Edensor et al., 2008, Hill et al., 2009, Anton et al., 2011).<sup>23</sup> But what is captured need not necessarily be on such a large scale to be useful. Video can also capture small gestures, expressions and moments which remind us of something intangible, something that may have slipped from memory otherwise.

Ethnographic interviews are perhaps the most useful context for video collection and production. The reason for this is that video is multisensorial, capturing sound, image, movement, gesture, time and place (see video 1, *Urban Explorers*). Again, turning to classical geographic ethnography work, Rowles and Watkins, in their work with elderly Appalachian communities, used film but then produced “verbatim transcriptions of filmed interviews” (Rowles and Watkins, 1993: 518). Though that work can and is effective in many cases, budding technical possibilities allow researchers to share multimedia much more easily, increasing the value of collected field data *as* research output.

Photographs, Hastrup argues (1992: 10), are a thin description, capturing form but not meaning. Hastrup goes on to write that in order for a photograph to become a

---

<sup>23</sup> The video can be viewed on the British Library Sports and Society page at <http://www.bl.uk/sportandsociety/legacy/articles/waterways.html> (accessed 10<sup>th</sup> October 2011).

piece of ethnographic thick description, it must be contextualized by text, an argument, as previously mentioned, recently made by Rose (2001). This idea might be disputed, given that photographs are also mediated through filters of multiple subjectivities and may also be “participatory”, but video may be more respectful and accurate in terms of ethnographic storytelling, primarily because participants gain visual as well as aural influence over a project and are able to have increased control both over what is seen and what is said about their images, especially in a participatory video environment (Shaw and Robertson, 1997, Sandercock and Attili, 2010). This makes our work more slippery and difficult to negotiate, but also potentially more rich and vibrant. Video also presents new problems however, as I illustrated above. As Winch told me, “I worry much more about someone shooting video of me because it’s so easily manipulated in the edit, that’s why we vet filmmakers so heavily and prefer them to already be part of the group before shooting anything.” (Winch, January 2012).

Of course, the explorer’s desire to keep tight control over their public images cannot escape critique. The long-exposure photography explorers produce, often with a person in frame looking smug about their accomplishment, are highly stylised, often reshot dozens of times to “perfect” them and look uncomfortably similar to traditional photos of Colonial explorers. They also, as mentioned earlier, often have a very masculine edge, with the explorer often doing something “dangerous” or “bait” in frame.

On this project, some of the most emotionally raw, intense moments, are when we are crossing the liminal security zone into a place. However, the group is particularly sensitive about filming or photographing these moments, since it

potentially “gives away access details” many times causing locations to get “sealed”. As a result, my initial fieldwork footage always begins inside places (see video 3, *Pyestock NGTE*). Later however, once I had gained a certain level of credibility as an insider, few had a problem with me filming entries and exits (see video 4, *Luton Bunkers*), I was trusted to be competent in multitasking (i.e. not getting everyone caught to “get my shot”) and would not post the footage publically unless prior agreements were reached. By the end of the project, little of what I did was questioned as my project participant knew I would be sensitive about what was posted where and when. A few times I overstepped in excitement and people were quick to ask me to take media down or change names, which I almost always did. Because of these prospects and difficulties, the researcher must be prepared to accept that “ethnographic strategies are... shaped by the subjects’ situations, their global as well as local perceptions, and their demands and expectations of us” (Josephides, 1997: 32, referenced in Pink 2007: 4). As a result, Josephides argues, whether we are writing, recording, participating or observing, “there can be no blueprint for how do to fieldwork... we have to construct our theories of how to do fieldwork in the field” (Pink, 2007: 79).

In terms of what constitutes ethnographic video, as Sarah Pink points out, “a video is ‘ethnographic’ when its viewer(s) judge that it represents information of ethnographic interest” (Pink, 2007: 79). In this case, my production of a short film about one of our first explorations of a nuclear bunker in Luton caused LutEx to tell me he was disappointed it wasn’t longer, that it took him right back to the bunker. Being my primary audience, I figured that was a success (see video 4, *Luton Bunkers*). LutEx and Winch’s comments about “going back” through media viewing are important.





Figure 23. Winch crossing the liminal security zone at NEO Bankside, London, photo by author

Although I will not argue here that video bridges the gap into becoming an embodied viewing experience (yet), it is the medium which most wholly conjures a multisensual facsimile of experience which also sparks renewed consideration of the tension between the embodied and the visual (see chapter 5) part of the reason why *Crack the Surface* (video 10) ended up being such a huge popular success.

Eric Laurier, upon reading Vivian Sobchack's book *Carnal Thoughts, Embodiment and Moving Image Culture* (Sobchack, 2004) notes that Sobchack wants us to realize that "cinema engages so much more of our bodies than the eyes alone... a film can touch a viewer and elicit a viewers' experience of touch" (Laurier, 2009: 11). This polysensuality also allows one to use film to map the unseen, to record emotion and memory – issues that are well recognized as contributing significantly to our perceptions of place (DeSilvey, 2007a, Edensor, 2005b, Edensor, 2005a, Davidson et al., 2005, Feld and Basso, 1996). As Youngs (1980: 3) points out, "film

therefore can provide data on at least two levels of consciousness – tangible and intangible.” Youngs goes on to proclaim, “personally, it is the latter that is most significant”.

While I find the embodied aspects of urban exploration most interesting to capture with visual media, we would be remiss to ignore those intangible in-between points as well. These types of depiction were especially important for this project since the practice is so much about feelings in places. There have been countless instances of atmospheric attunement (Stewart, 2011) in places that are, without a doubt, beyond representation (Lorimer, 2008, also see video 6 – *Prohobo 2.0*). In fact, much of what we do as urban explorers, I would argue, is an effort to tap in the sensory surreal (chapter 5), that which is beyond description or documentation. Video, given it is a multisensorial depiction, hopefully “stays close” here in an attempt to capture those moments that are difficult to describe. Part of this research was an attempt to map the inarticulable, to test those alternative forms of multisensory representations encouraged by non-representational (Thrift, 2008) and more-than-representational theorists who undertake “diverse work that seeks better to cope with our self-evidently more-than-human, more-than-textual, multisensual worlds” (Lorimer, 2005: 83). Video footage can become one avenue toward these alternative forms of experience beyond, or beside, written accounts.

Anthropologists using visual media describe video as a “culture map” depicting a “social landscape” and argue that video is particularly useful for the creation of “cognitive maps” (Crick, 1976 referenced in Hastrup 1992: 19), nomenclature that will find a particular resonance with cultural geographers grappling with largely

intangible information about conceptions of place, landscape, culture and especially mobility, ideas captured in the work of Laurier (2008), Spinney (2008) and Cresswell (2010), among others. Increasingly, geographers are reaching into intangible knowledge (that is, not rooted in materiality but in what might be called “essences”) to construct narratives of place (Edensor, 2005b, Edensor, 2005a, Edensor, 2005c, Edensor, 2008, DeLyser, 1999, DeLyser, 2004, Lipman, 2009, Holloway and Kneale, 2008, Maddern, 2008, Maddern and Adey, 2008). This work manifests itself in writings about memorial events, ghostly presences, feelings and emotions that embed themselves in places, hiding in dark corners to be invoked by a passerby, places where even a whisper shatters our perception of what is, what was and what could be. Video is one method of attempting to recall and relate those experiences to those who were not present (see video 1, *Urban Explorers*). In the case of this project, those types of experiment led to us undertaking an accidental participatory video project together.

### **Accidental participatory videography**

Eventually, after becoming more interested in learning photography, I started leaving my video camera at home. One night, when going into the South London sewers with Silent Motion and Statler, Silent Motion asked me where my video camera was. I told him I was leaving it at home and he said, “then I’m taking it!” That night, he prompted an accidental participatory videography when he made a film over the course of two days about our adventure (see video 8, *Sewer Skank*). While he was editing the film at my flat, I mentioned that I thought it was amusing he had filmed me and he responded “well, you’re an explorer just like the rest of us, why shouldn’t you be in the film” (Silent Motion, October 2010)? Working with him to iron out small glitches in the production made us closer friends because

“documentary filmmaking is by nature collaborative. Quite simply, it’s impossible to make a film about other people on your own” (Barbash and Taylor, 1997: 74). Through to the editing process (Laurier and Brown, 2011), one can come to a much better understanding of what it is that your project participants value by creating mediated work together (Laurier, 2009).

Participatory video, or community video (Hastrup, 1992, White, 2003), allows participants on a project to articulate, in their own words, what it is they wish to have conveyed and, ideally, as in this case, take control of the production process from the researcher. This technique was pioneered by filmmaker Jean Rouch in what he called the “audiovisual counter-gift” (El Guindi, 2004: 179). Johansson *et al.* (Johansson et al., 1999: 36) comment that they “cannot imagine a more effective method to quickly comprehend the often-complex perceptions and discourses of local people than to produce, watch, discuss and analyze PV material together with them” (Cited in Hastrup, 1992: 143). Despite desires to stay true to your informants’ thoughts and wishes in text, the written word will always be mediated through your own subjectivity, filtered through a mind which has been “colonized by the language of academia” (Bonnett, 1996b: 21). Participatory video gives research participants the opportunity to voice their own thoughts and opinions in their own way which ideally concludes with all parties seeing the film as an “ongoing process of creating community” (Sandercock and Attili, 2010: 37). Although this would of course be possible through, for instance, collaborative writing, video work was a short stretch for a group already heavily invested in photography.

There are a number of reasons why working in this way would benefit geography but of vital importance, in terms of ethnographic work in particular, is the concept of agency. The acknowledgement of, and willingness to share, authorship offers increased agency to your project participants. Taken to its logical conclusion, this will mean that by handing over control of your project you “expose the wiring” of the method (Pearson and Shanks, 2001) and begin to “destabilize hierarchical power relations”, shifting from doing work *about* people to doing work *with* people (Kindon, 2003: 142, also see Routledge, 2002). This type of ethnographic film work was done to great effect by anthropologists Sol Worth and John Adair with the Diné (Navajo) people of the American Southwest (Worth and Adair, 1972) and even earlier by sociologists Low and Snowden in the late 1960s in Canada (Frantz, 2007). These methods have, as of yet, not been replicated with such effectiveness in a geographic context. I hope this thesis is a stepping-stone in that direction.

Photographs also work well in these contexts – most people appreciate having photographs returned to them that they can use, distribute and archive and we often “flipped through” photos of our adventures and talked about them. It has been noted that “writing, especially academic writing, flees the particular and takes hold of the abstract, that enemy of experience” and that “sticking with the particular, sticking close with experience, is, if anything, more possible in anthropological film than in writing” (Devereaux and Hillman, 1995: 71-72). Working with video and photography on this project allowed me to capture those embodied experiences of being in places, the shared fear, excitement, danger and comical situations that made up our time together (see video 7, *Prohobo 3.0*) and also inspired me, when it came time to write, to share my writing and offer co-authorship in the same way.

A few months after Silent Motion made the South London Sewer Parties film, I was approached by Otter, who had in 2008 treated me with such disdain, asking me if I would help film the 2011 International Drain Meet. Unbeknownst to me, Otter had broadcast training and had been making a film with Johndoe for the past few months. He had already collected footage that was far better than anything I could ever hope to do. I accepted the invitation to collaborate and the video we produced together from the drain meet (see video 9 – *IDM 2011*) ended up being an important marker both in terms of my final acceptance as one of the group’s “filmmakers” as well as one of the points of collaboration between different groups of explorers in London (see chapter 4). Since the production of that film, I have had multiple people in the wider community asking me when “the PhD film” was going to come out, which ironically, was sidelined so I could learn photography and continue to collaborate with Otter on *Crack the Surface*, the film he was already working on before I met him (video 10).



Figure 24. Author filming at the 2011 International Drain Meet, London, photo by Luca Careno

**Expect the unexpected**

Throughout chapters 1 and 2, I hope to have given the reader a relatively grounded idea of what urban exploration is as a practice, who is involved, how I gained access and began working with the community and what my fieldwork method consisted of. As you will no doubt understand by this point, this was no simple process. My entanglements with the community, once established, will never be severed and remain, to this day, the closest friendships I have. That was what was required to be involved with this group.

However, those close relationships allowed me to spend a great deal of time, usually during road trips together, to drill down into the community regarding motivations and desires. What I expected to find is not what I learned in the end. I begin, as most explorers do, with an interest in derelict places and the “historical” aspects of urban exploration, which is where we will now turn in chapter 3.

### Chapter 3 – Assaying history: creating temporal junctions

“I have always looked upon decay as being just as wonderful and rich an expression as growth”.

– Henry Miller (1960: 28-29)



Figure 25. *Kasteel van Mesen*, Belgium, photo by author

The departure point for most urban explorers is an interest in exploring derelict and disused space. These spaces are appreciated for their aesthetic qualities, possibilities for temporarily escaping the rush of the surrounding urban environment, their enfolding qualities where nature/culture binaries are collapsed and their ability to hint toward a post-human future that reminds us of our own mortality. For the first year of my fieldwork, we explored many abandoned places in London and then began venturing in Continental Europe to find more, eventually driving as far as Poland to locate and camp in abandoned Soviet military bases and decaying industrial ruins. It is on one of these “urban camping” road trips that I begin chapter 3, which can be read in conjunction with my video essay *Urban Explorers* (video 1) and the *Hobohemia Video Triptych* (videos 5, 6 and 7).



### **A life in ruins**

“The poetry of history lies in the quasi-miraculous fact that once, on this earth, once, on this familiar spot of ground, walked other men and women, as actual as we are today, thinking their own thoughts, swayed by their own passions, but now all gone, one generation vanishing into another, gone as utterly as we ourselves shall shortly be gone...”

– (Trevelyan, 1949: 13).

*At the beginning of December, 2009, myself, Winch, Silent Motion and Statler were speeding down Highway A18 over the French border into Belgium as the sun set. This was the second time in three months we had been on this highway. After a year of exploring decaying architecture in and around London, our geographic imaginations inevitably expanded into other places, our desires to move further from our experiential comfort zones became irresistible. In October, we spent a long weekend in the Belgian countryside exploring derelict castles, asylums and factories, the first time we began sleeping in ruins. Our intrepid planner and navigator on both trips was Winch, a well-known, well-respected camera nerd on the London “B Team” with a propensity for telling off-colour jokes with just the right demeanour to get everyone laughing until they cry.*

*I am in the backseat, staring out at the passing landscape as we speed towards Liege in a small green sports car, Statler behind the wheel, the boot overflowing with camera equipment, gas station food wrappers and empty beer bottles. The landscape, a murky grey split by beams of orange as the sun disappears for the night, seems to contain more derelict buildings than live ones. I remind the crew that Rose Macauley once wrote “above and under the earth [there are] far more ruined than unruined buildings” (Macauley, 1966: xvii) and they all nod knowingly. After sneaking into hundreds of decaying structures together, we are all aware that each new building constructed is another building which will one day slip into ruination. These moments of liminality, the fragile point when a place seems like a look would crumble it, are what we search for.*

*With every derelict factory that we pass in a blur of untamed foliage, rust and jagged metal, the energy in the car increases. Silent Motion, sitting next to me and on his first trip to the continent, starts jumping around and clapping saying, “let’s go climb that!” and “ooh, that looks old!” Winch and I are drinking Chimay that we picked up at a petrol station and he is, as usual, scrolling around in Google Earth on his cracked Blackberry looking at an aerial view of our next location and photos on the Internet, trying to find a possible entry point into the building. He turns to us slowly and says, “So, you guys, we are staying in a hotel tonight...” Everyone looks stunned. “That closed in 1996!” causing the entire car to erupt in a riot of laughter (Field Notes, January 2010, Belgium, see video 5, Prohobo 2.0).*



Figure 26. Urban camping in *Kasteel van Mesen*, Belgium, photo by author

Urban explorers are fascinated primarily in the flotsam of the built environment. It is a practice intensely interested in locating sites of haunted memory, seeking interaction with the ghosts of lives lived (Maddern, 2008). When these places are located, their fragile deteriorations are captured in photos, “speak[ing] through photography to time itself, drawing the time before the shutter opened and the time afterwards together” (Crang and Travlou, 2001: 173, discussing Derrida's photography), creating moments of temporal juxtaposition in an “illusion of control over eternity” (Reynolds, 2002: 264) as explorers anticipate the inevitable transience of these places (DeSilvey, 2011). My role, as outlined in chapter 2, was to capture them capturing this in addition to participating. From 2008, when I first met Winch, Marc Explo and others, we began a systematic process of locating and exploring all of the derelict places we could find, from abandoned bunkers to hospitals to industrial sites.

Through those explorations, we found moments of encounter between the present and the past. Through the physical exploration of abandoned architecture, confrontation with unexpected material traces flare up. These meetings have the potential to lead to emotionally-charged discoveries through an embodied praxis which mirrors the role of the archaeologist assaying surface material without deep excavation to analyse the character of places; a surface survey of affectation. As a practice that temporarily inhabits sites of material history, urban exploration constructs assemblages of complicated emotional and memorial attachments to abandoned places that melds pluritemporal geographic, historical and experiential imaginations to assay history. Found material such as personal notes, clothing, toys, computers, tools and equipment as well as buildings hidden from plain sight in the middle of the city, sometimes buried deep under the urban façade, lead to revelations that cracks in spatial and temporal structures can be exploited to build alternative associations. These cracks, what I have called glitches and Michael Cook (Manaugh, 2009) calls vanishing points, are the inevitable in-betweenness of urbanity.

On a January 2011 trip to Paris with Winch, Marc Explo, Dsankt, Iris, Olivier and Otter, Winch writes about the glitch in terms of Paris exploration,

The glitch here is that you will never secure the system. No subterranean network of train tunnels can be closed off in its entirety, for there are too many potential routes in. The passengers take a route in each day, and the trains surface on the periphery of the routes. These are portals to the outside, and it is through these differing types of portals that the glitches can be found. We have realised on this trip that to explore a system like this is to find the glitch, however that might be. Providing that the knowledge of the glitch in the system is protected, the system is open.<sup>24</sup>

---

<sup>24</sup> <http://www.thewinch.net/?p=1970> (accessed 6th May 2011).



Figure 27. An artefact jumble at the West Park Asylum, Surrey, photo by author

Although it can be argued that this is a shallow form of discovery, in terms of historical interest (Bennett, 2011), I contend that urban exploration is as much about space as it is about time, as much about the event as it is about the accumulation of knowledge, as much about “things” as people (Bennett, 2004, Bennett, 2010). In contrast to a historian working deeply on one topic or site, urban explorers have mental and virtual databases of hundreds of historical sites, connected though experiential revelation (see appendix B and appendix C). Luke Bennett, who did research on urban explorers in the UK interested in ROC Posts – a type of subterranean military bunker – notes that “participants appeared to be working something through, either a retained childhood instinct to explore, an obsessive desire to catalogue, or some form of a veneration process” (Bennett, 2011: 437). Bennett is correct, the dissected, deteriorating and confused narratives these places offer can indeed provoke deep self-reflection.

Urban exploration gives agency to places with an appreciation for the life of an architectural feature or system that continues after abandonment, with an acknowledgement that though the capitalist use life of all places will inevitably end, places do not “die”. There seems to be an assertion that there is no wasted space, there are no non-places, there are just places cared for and remembered in different ways. Where and how to interpret these post-abandonment stories, regardless of who “owns” them, in an economic sense, or whether they are “true”, in an empirical sense, is guided by the people who are personally invested in those places, whether or not they are invited to. RomanyWG writes that “to be that explorer at that moment is to be given back the power to tell those stories for yourself” (RomanyWG, 2010: np).

In contrast to the “deep care” exhibited by heritage managers, appreciation of history through urban exploration does not normally invoke a material preservation instinct. Places are experienced, enjoyed, recorded, loved and appreciated in the present but material remains are not prevented from continuing their mutations toward inevitable material obscurity (DeSilvey, 2006). Additionally, steps are taken, in many cases, to minimize impact to places during visitation so as not to impede decay or alter the sanctity of the experience for future visitors. Some urban explorers attempt to impose this imperative with vigilance through the enforcement of the “code of ethics” mentioned in chapter 1.

In our relationship with places, especially in the context of heritage management, we often ask the question “what meaning shall we assign this?” or “why is this place important?” We rely on the voice of a guide or narrator, an expert, to mediate our relationship, to explain why it is meaningful – less often do we let places speak

to us directly. However, “history, in the hands of a professional historian, is bound to present itself as an esoteric form of knowledge” (Samuel, 1994: 3). In the practice of urban exploration, it is “not the philosopher or the scientist who [do] the pioneering but the solitary, uninformed traveller, setting out, hardly knowing why, in search of a new kind of knowledge” (Jackson, 1980: 4). If urban explorers, as Dsankt tells me, “do it because we want to do it, not out of a grand sense of preservation” (Dsankt, January 2011), what then can we learn from taking the unguided tour where the important historical attributes of a place, for instance the intense working conditions experienced by employees over the course of many years (Milkman, 1997), is overwhelmed by the sensory, emotional, affective experience of simply being there, watching those histories slip into oblivion?

It is perhaps the case that in such situations, explorers are less connected to the histories of those places than they might like to think. Yet it is not possible to quantitatively or qualitatively measure our affective relationships, the extent to which, for instance, atmospheric attunements built on concreted memories in places have the ability to effect us (Stewart, 2011), for many times this registers viscerally, precognitively and can only be decoded in aftermath. What we can say, for certain, is that exploration of these places, in the here in now, stretches the *histories* of these places into the *stories* of these places (Lorimer, 2003), extending an ongoingness of place that persists before, during and after the exploration event. In cases where we are not likely to rely on urban exploration accounts to relay the historic significance of a place, the particular reverence that the practice pays the place itself, the small details, the forgotten traces, should surely be seen as a welcome addition to a heritagescape rendered increasingly banal by negotiations with policies of economic relevance. When I asked Silent Motion, on the way out of

an abandoned factory called Sinteranlage in Germany, whether he felt he learned anything about the place, he told me “exploration is, on some level, always a process of becoming less ignorant, you can’t have an experience like that and walk away with nothing.”

Also in contrast to “interpreted” heritage, urban explorers harbour no temporal or typological constraints to an appreciation of the past. An urban explorer may find as much significance in an abandoned grocery store closed down last week as in an 18<sup>th</sup> century castle in Belgium, pointing, again, to those intersections between historical appreciation and present day experience. Additionally, as I will show, places with beautiful, amusing, disturbing and dark histories are all given space for recognition, exploration and recordation through urban exploration. I will revisit each of the concepts in turn, but let me begin by discussing the relationships between preservation and decay in the practice.

### **The preservation anxiety club**

“But just wait until now becomes then. You’ll see how happy we were.”  
– (Sontag, 1977: 42)

At interpreted historical sites around the world, we are consistently confronted with the notion that in order for people to have a sense of self, they must have a sense of the preserved past. The English Heritage website proudly proclaims that it “exists to protect and promote England’s spectacular historic environment and ensure that its past is researched and understood.”<sup>25</sup> Meanwhile, on the US National Park Service website, they declare their willingness to work with those “who believe in the importance of our shared heritage – and its preservation.”<sup>26</sup>

---

<sup>25</sup> <http://www.english-heritage.org.uk/about> (accessed 11th November 2011).

<sup>26</sup> <http://www.nps.gov/history/about.htm> (accessed 11th November 2011).



Figure 28. The abandoned factory Sinteranlage, Germany, photo by author



When you visit historic sites like Dover Castle in the UK or Bodie ghost town in California, what you will encounter embodies the keywords outlined in these statements. Preservation. Research. Understanding. Heritage.

These concepts are valuable and the research that stems from them is important, but as Doreen Massey (1994) suggests, government bodies, working in the interest of national agendas, many times motivated by profit, are often the entities who define heritage. These places are then used by the state to assert a moral right over the landscape, subjugating a many times reluctant citizenry to a consistent erosion of rights to personal space and freedom to decide for oneself which heritage is retained as social and cultural identity markers and which discarded as irrelevant.

This can, at times, incite populist reaction against what can be seen as a homogenization of cultural identity, particularly in cases where visitors realise that representations of history presented as singular narratives are in fact more complicated than they are presented. These complications are often sidelined so the historical narrative makes more sense or to avoid disturbing and dark histories. J.B. Jackson writes “there is hardly an enterprising town located on the more popular tourist routes that does not have some kind of reconstructed historical environment. Some are reasonably conscientious attempts at reconstruction, some are entirely make-believe” (Jackson, 1980: 90). Preserved Spanish missions in California, for instance, say little to nothing about the murder, rape and enslavement of indigenous people that took place within their walls (Costo and Costo, 1987) although Native Americans make constant demands for the “other” histories to be remembered (Garrett, 2009).

As a result of a desire to have more personal investment in places, public reaction to state-mediated historical interpretation is, in many cases, disdain. In the course of Dydia DeLyser's work at Bodie ghost town, she spoke with two visitors, a husband and wife. The wife told her "we were just in Virginia City [Nevada] and Bodie is so much better. This isn't commercial. Over there, every time you walk into a building, somebody's trying to sell you something.' Her husband concurred: "This is so much more authentic." Other visitors DeLyser later speaks to deem Bodie "inauthentic" when they find that "modern" materials have been used to stabilize buildings onsite (DeLyser, 1999: 617). A few years after DeLyser had left, I visited Bodie and saw a young girl standing behind a rope which was preserving a room in a state of arrested decay. The girl was clearly frustrated by the barrier, and asked her father, "...but who decided I can't go in there?"

DeLyser's work at Bodie suggests that while many people want a sense of history, some are also looking for more than a "passive past constructed through a scripted narrative" (Harris, 2010: 47). These individuals are looking for some level of authorship over and engagement with that history, whether that calls for an embodied engagement with a place (Edensor, 2007), a more interactive experience (Witmore, 2005) or an opportunity to take part in its interpretation (DeSilvey, 2007b). As the urban explorer Wolfism writes, urban exploration gives you "the opportunity to feel you're in close touch with history, up close as opposed to in a glass case... [places] completely forgotten by history books" (RomanyWG, 2010: np).



Figure 29. A room in a state of arrested decay, Bodie Ghost Town, California, photo by author



Figure 30. Something(s) in transition, *Salve Mater* Sanatorium, Belgium, photo by author

One of the places where this sort of localized history-work can take place is in modern ruins (Hell and Schönle, 2010), where interpretation can be composed at the confluence of embodied experience, imagination and memory through unsanctioned exploration. Exploration of this nature requires a great deal of effort, but feeling a sense of place that resonates emotionally sometimes requires deep investment, as *Silent Motion* stated in chapter 1. Through these investments, we can build a sense of history that is as much about place as about time (Samuel, 1994: viii) or as much about connections as about places.

Through urban exploration, individuals take the opportunity to create memories of places that can sit alongside, or at times even undermine, official histories, creating a symbiotic exchange between body and place, building a deep sense of historical embodied engagement where explored spaces are “not architecture at all, then, but something more strange and inexplicable: structural blurs without identifiable purpose or history” from a “semi-toxic world of old military equipment and abandoned shopping malls – wastefully complex and tinged with melancholy, but gorgeous nonetheless” (Paiva and Manaugh, 2008: 6-7).

Gross (2000: 77) has stressed that “particular elites, groups, or institutions have attempted to dictate which values, facts, or historical events are recalled, how this information is remembered, and the types of emotions attached to these memories” (Legg, 2007: 459). As space becomes increasingly codified, especially in terms that ensure a profitable “heritage market” in late capitalist society, people seek alternative ways to locate memorial thickness, experience devoid of the need to empirically quantify, rationalise, or sell narratives to the next passing cultural history tourist (DeLyser, 1999, Crang, 1996, Edensor, 1999, Neumann, 2002, Stone

and Planel, 1999). In short, people are looking for an experience of the past that resonates outside of the commodification of late-capitalist cultural control or social expectation. Harold Rosenberg wrote there was a,

Process of depersonalization and passivity' brought on by modern social organization, the extension of 'the psychic condition of the nineteenth-century factory worker' into the totality of twentieth-century society... [where] ...members of every class surrender themselves to artificially constructed images that promise to restore their links with the past and future (Marcus, 2001: 43, referencing Rosenberg, 1970).



Figure 31. A beautifully toxic dumping ground, *La Cokerie d'Anderlues*, Belgium, photo by author

Urban exploration weaves part of the fabric of recognition that history is constantly being made and remade by a variety of actors outside of those capitalist spectacles of History (with a capital H). This work, often unsanctioned, frequently comes with a desire to fold the past into the present, creating pluritemporal encounters, "calling forth those memories that satisfy the needs of the present" (Legg, 2007: 458). In *Civilization and its Discontents*, Freud writes about a dream of standing on the Palatine Hill in Rome and imagining the city as a palimpsest, an architectural parchment on which many series of inscriptions can still be detected

below the most recent text written upon it (Pensky, 2005, Bender, 1998, Huysen, 2003), all available for psychological delving, regardless of their material or immaterial state. This type of memory work is as much a freedom of thought as action. Urban explorers do not argue that this freedom should be offered, necessarily, but that where it is not offered, it should be taken. As Patch told me during an exploration “what I choose to do here doesn’t belong to anybody, it’s mine.” Urban explorers insist on the right to temporarily reside in places to enjoy them on their own terms, creating “counter-topographies” (Katz, 2004) that playfully undermine hegemonic discourses of globalisation and understandings of land and buildings as simply property (Jonker and Till, 2009: 307).

An iteration of this fragile stratigraphy is described by Caitlin DeSilvey, who invites us to “imagine a place where the past lies thickly under a layer of dust, and where the simplest act of retrieval kicks up clouds of uneasy speculation. Junk or treasure? Waste or artefact” (DeSilvey, 2007a: 878)? In DeSilvey’s world, the oneiric qualities of the fragile ruin and irresistible material resonances excite our imaginations. Jane Bennett also celebrates this exchange in her work on “thing-power” where she writes that these types of encounters “entail the ability to shift or vibrate between different states of being, to go from trash/inanimate/resting to treasure/animate/alert” (Bennett, 2004: 354). This is the matter of Walter Benjamin’s (1998) “irresistible decay” and comes through in the thoughts of urban explorer Jeremy Blakeslee:

These places become like a drug for some reason. Places of this magnitude get you high, a combination of the history, the architecture, the light moving through, the smell of one hundred years of motor oil in the internal combustion blowing engines all over the floor like blood. And you are just another layer in the history of the place (Blakeslee quoted in Rapp, 2010: 12).

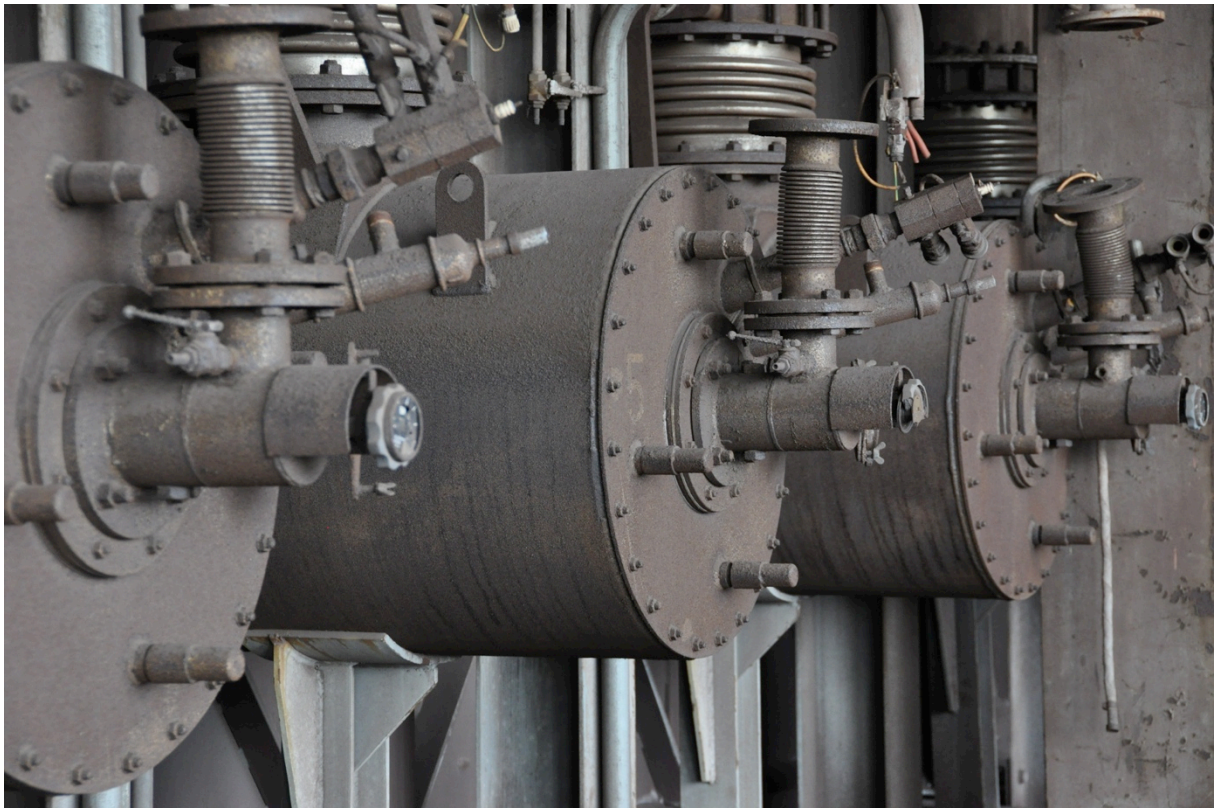

Figure 32. The appeal of industrial decay, *Cokerie Zollverein*, Germany, photo by author

By exploring ruins of the past on our own terms, and allowing them to continue their decay unimpeded, we begin to subvert “a desire to continue inhabiting imaginary identifications that are out of joint with present-day social-symbolic realities” (Steinmetz, 2010: 299). Investment in ruins as places of alternative experiences, such as those described in the writings of Tim Edensor (2005b) have challenged and complicated our ideas about not only what constitutes the ruin as an external imaginary (Hell and Schönle, 2010) but also what these places might contain and/or offer.

*Back in Belgium, we have indeed stopped at the hotel that closed in 1996. It is called Kosmos and at 10pm, in a light rain, we are climbing around on the tin roof hanging over a cliff on the back of the place, our shoulders piled with our sleeping bags, cameras and torches, looking for a broken window since we found the first floor of the place boarded up tighter than expected. As usual, we eventually locate a smashed out window and climb through, the point of spatial penetration blending into the point of historic access. Inside, we to find a few old vinyl couches covered in pigeon feces and some water-warped book shelves with a skyline view of an anonymous valley, twinkling lights mystifying us beyond the derelict pool on a lower terrace of*

*the backyard. We set up tea lights in the old bookshelves, sipping whiskey obtained on the ferry to Calais, thankful to have found shelter for the night.*

*As we sat together with the wind ripping broken glass out of the twisted window frames, aurally tortured by some bit of metal getting smashed over and over again on a part of the roof we can't reach, Silent Motion tells us that never before has he felt so wrapped in the fabric of a place. Temporarily living in ruins, what the community came to call "urban camping" (or going prohubo) folded us right into the materiality of places, uncomfortable as that sometimes was.*

*In the morning, we were walking out over the cracked tarmac of the parking lot, hitchhiking weeds grabbing at our trouser legs, headed to the car to speed to the next location. We briefly stopped to look back at the Kosmos Hotel and consider our night there. I asked Silent Motion if, feeling like he is now part of the fabric of the place, he would like to see it preserved in some way. He laughed and said, "hell no, that place is a shithole – look at it"! I wrote in my notebook as we drove on that we are less attached to the places themselves than to the history, memory and experiences of these places, which may remain even when the material remains are eradicated. Nobody is nostalgic about the material remains of the Kosmos hotel. We felt that both ourselves and the hotel enjoyed the experience, it was a fair exchange, and the memories began their accretions (Field Notes, Belgium, January 2010).*

Urban explorers quarry material and immaterial, functional and fantastical, rational and irrational histories of places. They create myths about places that become embedded in them. The stories of a night spent sleeping on the decrepit vinyl couches in the screeching winds of a cold Belgian winter become just as much a part of the place as the stories from its use-life. At times, we encounter other people in places, especially the further we get from areas of relative economic prosperity. Those encounters, sometimes just consisting of an apology while turning to leave and other times small conversations about the place we found each other in, also remind us that use-lives continue even where the primary industry that inspired the structure's construction has dissolved.





Figure 33. Urban camping road trip, Kosmos Hotel, Belgium, photo by author



Figure 34. Winch, the author, Statler and Silent Motion inside the Kosmos Hotel, photo by author

Urban explorers seek to touch everyday lives in the distant and near past and to celebrate “a different past, not the past which history books describe, but a vernacular past...” (Jackson, 1980: 94-95). In these forgotten places, history is “a social form of knowledge, in any given instance, of a thousand different hands” (Samuel, 1994: 8). Exploration, urban or not, is defined primarily by the spontaneous find (or at least the search) for the unexpected. Assaying for the “the random, the unscreened, allows you to find what you don’t know you are looking for, and you don’t know a place until it surprises you” (Solnit, 2001: 11). As anthropologist Keith Basso writes,

Places possess a marked capacity for triggering acts of self-reflection, inspiring thoughts about who one presently is, or memories of who one used to be, or musings on who one might become. And that is not all. Place-based thoughts about the self lead commonly to thoughts of other things - other places, other people, other times, whole networks of associations that ramify unaccountably within the expanding spheres of awareness that they themselves engender. The experience of sensing places, then, is thus both roundly reciprocal and incorrigibly dynamic (Basso, 1996: 55).

During my research with urban explorers, it has become clear that surprises can exist around every corner, finding them is just a matter of adjusting where one might look.



Figure 35. Ruin infiltration as play, "Gary" and author hiding from the security patrol, Spillers Millennium Mills, London, photo by author

**Reimagining remembered place – the recent past**

“I hear the ruin of all space, shattered glass and toppling masonry, and time one livid final flame. What’s left us then?”

– James Joyce (Joyce, 1990)



Figure 36. The author looking out over the *Sinteranlage* factory, Germany, photo by author

High and Lewis, in their recent condemnation of urban exploration as a shallow spectator sport practiced by “white, middle class North Americans in their teens and twenties” (2007: 63) contend that “urban explorers are more interested in aesthetics than history” (2007: 55). The authors draw these conclusions in contrast to their work on industrial places in the American Midwest where they have located previous employees of those places and recorded some of the rich personal memories connected to the industrial ruins. Their work is fascinating, yet it glosses over much of what constitutes the ruin, firmly establishing “value” as solely memorial rather than potentially experiential and clearly preferencing human over non-human elements of places. They also singularly focus on the

capital use-lives of places, largely ignoring what those material traces might mean to groups other than ex-employees or property owners.

Following from that, what of newer ruins, modern ruins, places with shallow, comical or forgotten stories? Unlike High and Lewis (and heritage “experts” in general), local communities, including urban explorers, do not select places only for their emotionally charged memorial value, they find excitement and intrigue in exploring ruins from all ages and in piecing together, more archaeologically than historically, the rich and entwined pasts of those places. A joy is found in allowing those stories to become reentangled with the biological world, “to resist that punch line, to elide its truth, for it inclines thinking and perception too much toward the primacy of humans and ‘the subject’” (Bennett, 2004: 358). High and Lewis seem to want to assert that ruins should always be socially constituted. But personal, informal identification with places, what happens during the urban exploration “event”, at sites which are perhaps less historically inspiring than grand sanctioned monuments are still cared for in this way.

As Le Corbusier once wrote, we piously work to preserve the Coliseum, yet we allow the locomotive to rust in the scrap heap (Corbusier, 1987: 50-51). Today, we may revere the locomotive yet label the pile of old printers or stacks of floppy disks as “trash” or “waste” (Hawkins and Muecke, 2003). How much temporal distance is necessary to appreciate a place or the artefacts within it? For urban explorers, it seems the answer is very little, in contrast to nostalgic norms normally found in historic accounts. Writing about the urban explorations of Troy Paiva, Geoff Manaugh muses that “...the quasi-archaeological eyes of those poets and artists [from the past] would still be enraptured today. Wordsworth could

very well have gone out at 2am on a weeknight to see the cracked windshields of car wrecks on the sides of desert roads, new ruins from a different and arguable more interesting phase of Western civilization” (Paiva and Manaugh, 2008: 7).



Figure 37. History in the making, University of Liege, Belgium, photo by author

In one instance, “Team B” explored the Courage Brewery in Reading days after its closure and it was, by all accounts, a favourite site that the group revisited many times. Silent Motion, climbing the brewery tanks, declared, “this place is still alive – it’s still humming (Silent Motion, June 2011)!” Courage brewery, eighteen months later, was gone. For all they know, the pictures the explorers took of it (illegally) were the last documentation of the place before it was materially obliterated.

Urban explorers enjoy experiences in places from the recent past as well as the distant past. Part of this enjoyment lies in the idea that by visiting places that have been recently abandoned, we encounter artefacts of abandonment which are familiar to us and invoke spectres of unexpected (Holloway and Kneale, 2008) and

involuntary memories, conjuring what Tim Edensor calls “intersecting temporalities” (Edensor, 2005a: 834) where the “past becomes available to, and the same as, the present” (Crang and Travlou, 2001: 463).



Figure 38. Artefact? Place? Waste? Art? *Montzen Gare, Belgium*, photo by author

Paul Reyes worked with his father in Miami, Florida, just after the 2007 financial meltdown, cleaning out foreclosed homes where homeowners were evicted or had abandoned them. Regarding his experience, he writes,

...I can't help but read a narrative in what has been discarded. I begin to pick, sweating nearly every item we throw away, creeping among gadgets and notes and utility bills and photographs in order to decipher who lived there and how they lost it, a life partially revealed by stuff marinating in a fetid stillness. It is a guilt-ridden literary forensics, because to confront the junk is to confront the individuality being purged from the place (Reyes, 2008: 31).

Whether by human, botanical or animal intervention, the discard or destruction of these objects will inevitably take place. A sense of privilege and respect comes with knowing that you shared time with these things, somebody else's material memory fragments, some animal's den constructed from attic insulation, some vine's

contorted pathway over a control panel toward sunlight beaming through a missing brick in the wall, before their materiality folded back into the earth. This sense is often what is transmuted into the preservation instinct. Notice how in Reyes' description however, he does not contend that these things need to be saved, just that he is indeterminably fascinated by them. His fascination does not lead him to feel as if he has the authority to decide whether or not they are important or significant; Reyes is reluctant to take control over somebody else's past at the same time he feels privileged to have glimpsed it.



Figure 39. Botanical intervention, *Cristallerie du Val Saint Lambert*, Belgium, photo by author

*On January 2009, I was taken on my first explorations in the United Kingdom by spiky-haired urban explorer called Vanishing Days. We visited four sites that day ranging from a Napoleonic era fort to a World War II battery to an equestrian centre closed down in 1986, all of which he said he visited frequently. When we stopped and sat on a small crumbling brick wall in the equestrian centre to catch our breath toward the end of the day, I asked him why he came to that place when we were clearly surrounded by many more historically "significant" sites.*

*He told me that he loved the story of the place. It was a story about an eccentric old millionaire who had begun building the centre and who*



*consistently made impossible demands for permits and strange architectural components, causing both the local council and the construction company to balk. Finally, after years of endless building and rebuilding, the millionaire was out of money. The best part about the equestrian centre, Vanishing Days tells me, is that it was only open for a few months before being shut down again. He was enchanted by the ridiculousness of the place.*

*As we entered one of the rooms of the building, careful to avoid the nails sticking out of the floor where people had been ripping the copper piping out of the planking, a wallpapered mural of a horse half-peeled off and flapping in the wind above us, we found a stack of pamphlets published by the Kent Visitors Bureau from 1985 which include the failed equestrian centre in its list of “top ten attractions”.*

*Vanishing Days shined a light on the pamphlet so I could film it and told me, “I just love how sad this place is. Can’t you feel it?” In fact, I had felt it since we squeezed through the fence into the grounds, it was sodden with a prevailing comical tragicness through and through (Field Notes, Kent, UK, January 2009).*

The equestrian centre is now more memory than history, given “history is posed as the story of the triumphant and the literate, whereas memory is the democratic enterprise of oral traditions, folklore, and material culture” (Legg, 2004: 481, also see Taylor 2003) and while I don’t contend that the “official” history of the equestrian centre, wherever it exists, is invalid, I do contend that the oral traditions and folklore that urban explorers (amongst others) have built around the site are just as important (see video 1, *Urban Explorers*).

From abandoned cinemas to collapsing shopping malls to empty hotels, my project participants have taken me to many recent abandonments. Urban Explorers are interested in both the lives lived in those places, from pre-construction to post-abandonment, and in the life of the building itself. They are interested in the aesthetic qualities of architectural remains but realise the impossibility of dissecting them from the people who lived and worked in them, an important point made by High and Lewis (2007). Winch, as we walked around the Soviet Military Base Vogelsang, exclaimed “can you imagine this place swarming with

Soviet troops, doing parades around here and ferrying all this food and materials deep into a German forest so far from home? Mental..." Statler responded, "Mate, if we were seeing that, it would be the last things we saw, I assure you" (Winch and Statler, August 2010). Clearly, everyone in attendance felt honoured to see able to see the remains of the desolate location, and also enjoyed imagining this alternative reality, sneaking around in a base full of Soviets. Explorers are actors in the constellation of myths about places, whether or not those myths are historically (in an empirical sense) verifiable. This sort of knowledge work is built on the idea that a "sense of the past, at any given point of time, is quite as much a matter of history as what happened in it" (Samuel, 1994: 15) and these complicated historic narratives are what create deep and interesting senses of community, built from the bottom up. The equestrian centre that *Vanishing Days* took me to, perhaps to the dismay of the property owner who may have seen it as a "failure", is very much an integral part of the character of that community.

Tom Vanderbilt tells a story of his myths being shattered as he climbed around what he thought was a set of abandoned atomic bunkers in the American Southwest:

As we explored the area around the bunkers, a collection of wood structures overseen by a rickety observation tower, we would occasionally find scraps of wreckage jutting out of the pale white sand. It seemed a trove of modern archaeological history, and as we climbed the tower we imagined ourselves gazing on the site the way some sentry must have once done. As I found out later, however, both the aged military surplus sitting in the sand and the observation tower were traces of not Cold War history [but] of the film *Con Air*. We could still find scatterings of weathered Hollywood paperwork in the various buildings (the tower was later removed for *another* film)" (Vanderbilt, 2002: 20).

Vanderbilt's experience, though perhaps disappointing initially, leads him to invest his own meaning in the place, for which he is gifted back a different story. The

“authenticity” of the stories there are just one component of a rich assemblage, “underpinning convoluted time [that] is a dispersed, not a unifying, memory” (Crang and Travlou, 2001: 170).



Figure 40. A relief of Lenin at the Soviet military base *Vogelsang*, Germany, photo by author

Pasts are constructed. They are constructed through experience, memory, forgetting, political agendas, spontaneous encounters and myth-making processes, all perspectives and encounters just as “valid” as another. When we allow places to teach us about themselves, when we give agency to places, we begin to build rich tapestries that enticingly rearrange images of our past and, as a result, satisfyingly displace our images of who we are, allowing us to give a part of ourselves to places and “when you give yourself to places, they give themselves back...” (Solnit, 2001: 13). These entanglements are subjectively constructed and appreciated, adding an ever-increasing depth to our existence, encounters and interpretations. In these moments, individuals build history through experience where “memory and myth intermingle, and the imaginary rubs shoulders with the real (Samuel, 1994: 6).

Perhaps most importantly here, building on the foundational values behind urban exploration, it is our responsibility to take control of these narratives, to create the constellation of meanings that we would like to see created rather than wait for those narratives and experiences to be offered. Urban explorers do not necessarily want to create “problems” for bureaucracy by complicating those agendas but clearly do seek to create room for their own stories in places and to be able to open gaps for others to do the same. The goal is, turning back to our central notion of place hacking, to turn place into an open source code that can be recoded indefinitely and to recognise that despite appearances to the contrary, this was and is always the case. Even Disneyland can be decoded.<sup>27</sup>



Figure 41. Sophie and the author playing with a control panel in Abbey Mills Pumping Station

---

<sup>27</sup>In 2009, the urban explorer Shane Perez snuck onto to Disney’s abandoned Discovery Island in Florida: <http://shaneperez.blogspot.com/2009/12/discovery-island.html> (accessed 7th January 2012).

**Do-it-yourself interpretation: past mastering dark histories**

“Understanding the past embraces all modes of exploration.”

– David Lowenthal (1985: 211)



Figure 42. Past mastering: the author wearing a Nazi soldier helmet, Poland, photo by Winch

As Karen Till (1999) writes, some places are more challenging to keep in sight and memory, some places contain a darkness that incite calls for their destruction. Other places seem culturally or socially vacant, leaving one with little to visually process. Many would seek to erase these places from memory, including those who interacted with them during their use-life. Theo Richmond, a developer from New Hampshire, was quoted in *The Guardian* as saying “preserve a steel mill? It killed my father. Who wants to preserve that? (Richmond, 1973 quoted in Lowenthal 1985: 403). High and Lewis write about the spectacular explosive destruction of industrial spaces in the American “rust belt” and adjacent Canadian factories. In April of 1988, over 28,000 people gathered to watch the destruction of the Montreal Miron quarry smokestacks. The event, in the words of the authors, became a sort of “secular ritual” (High and Lewis, 2007: 32), a blast against the

past to heal the wounds inflicted by the corporate entity that ran the factory until the doors were shuttered and at the same time a celebration of the memories that filled the place.

In California, a site called Manzanar was one of the locations where the US government forcibly interned 120,000 people of Japanese ancestry during World War II (Burton et al., 1999). As a site of negative heritage, many wanted to see the place materially erased. Local community groups, however, banded together to save the site which is now run by the US National Park Service as a location that Carolyn Strange might label a place of “dark tourism” (Strange and Kempa, 2003, also see Dobraszcyk 2010 on touring Chernobyl). In post-Soviet Moscow, Legg discusses “the actions of the public in honouring, profaning, or even destroying statues allows them to “speak back” to the state” (Legg, 2004: 484).

On our third European road trip in 2010 with Winch, “Gary”, Statler and myself, when we encountered an 8-foot statue of Lenin at an abandoned Soviet base called Nohra in Germany, I felt an inexplicable need to climb it (see video 7, *Prohobo 3.0*). I think, looking back on what the other explorers seemed to think was a reasonable reaction, I desired an embodied exchange with a Cold War history that meant so much to my parents and so little to me. We all laughed, slapping and assaulting Lenin and then sped off into the forest. On some level, this was just what we needed in the moment and clearly would not have been encouraged inside a heritage park.

As with small stories and recent histories, dark stories are often more complicated than they may appear at first glance. Meskell points out that “as a site of memory,

negative heritage occupies a dual role: it can be mobilized for positive didactic purposes (e.g. Auschwitz, Hiroshima, District Six) or alternatively be erased if such places cannot be culturally rehabilitated and thus resist incorporation into the national imaginary (e.g. Nazi and Soviet statues and architecture)” (Meskell, 2002: 58). This doxic view is a tired rehearsal of the Appolonian/Dionesian modernist trope. Integration or annihilation. Interpret it or blow it up.



Figure 43. Inside a Soviet military gymnasium, Soviet base *Vogelsang*, Germany, photo by author

Urban explorers are one group however that find solace in the morphing materiality of the ruin, where, after sneaking past the exclusion zone of hoarding, palisade, barbed wire security patrols and “no man’s land”, difficult memories are negotiated at a pace, time and manner of one’s choosing. The gradual enfolding of space, lacking societal and cultural expectations for assimilation or obliteration, inspires a satisfying embodied slow collapse of nature and culture, of space and time. Ruin exploration can involve “reflections about history: about the nature of the event, the meaning of the past for the present, that nature of history itself as

eternal cycle, progress, apocalypse, or murderous dialectic process” (Hell and Schönle, 2010: 1), a process that creates “a heritage with which we can continually interact, one which fuses past with present” (Lowenthal, 1985: 410).



Figure 44. A continuing meld, *Château de Noisy*, Belgium, photo by author

It is in these moments, like my reaction at Nohra, where we might make the decision to leave our mark, to take more than photographs and inscribe a place with our own feelings and memories. Importantly, that is our choice to do while trespassing in ruins and although most urban explorers stake claim to an aim not to change the ruin in an effort to preserve the liminality of decay, sometimes this is just what is required.

As mentioned earlier, urban exploration writing has been described as a “postmodern version of Fodor’s [travel guide]” (Wershler-Henry, 2005 quoted in High and Lewis: 42) for the movement’s focus on small and fractured stories (Lorimer, 2003), individual artefacts (DeSilvey, 2007a), embodied accounts



(Edensor, 2007) and depictions of single experiences where “close, detailed description seems to suit the visible remnant just as photography seems to be its main medium” (Hell and Schönle, 2010: 7).



Figure 45. River Monkey lying in somebody else's coffin, *Salve Mater* Sanatorium, Belgium

These small stories, insignificant as they might seem staged against grand narratives, gradually stretch and erode boundaries and memories and are vital to any notion of a “living history” (Handler and Saxton, 2009). Living history, as I have now shown, is an important example of the meld where past, present and future fuse and morph in ways often beyond our control.



Figure 46. The author, Silent Motion, Winch and Statler camping at the Soviet hospital *Grabowsee*, Germany, photo by author

The postmodern origins of the contemporary urban exploration movement are apparent in the rejection of a singular grand narrative, but also in the playful participation with history, in its willingness interrogate its own becoming (Hell and Schönle, 2010: 7). Places are ventured to despite (or even because of) the danger or horror of the experience; poignancies and fallacies of sites (and the practice itself!) are given equal attention. “Gary”, inside a factory in Germany, called out to me across a room and said, “hey Brad, watch this, I’m going to document some ‘history’” (“Gary” July 2010) and took a photo of a broken window, laughing. Reactions to encounters with these places might appear uncouth or even dangerous at times but in the absence of mediating external forces like preservation expectations, those reactions are more clearly visceral and organic. By the end of our trip to Europe, we found ourselves encamped near Berlin barbequing dinner over broken doorframes from an abandoned Soviet military hospital, a place we never could have seen 20 years ago. The irony was lost on no one.

The materiality of ruins crumbles in our hands as we touch them and encounter “memory only in glimpses, through acts of imagination and empathetic identification” (DeSilvey, 2007a: 892), an identification which animates these places with human and animal blood and sweat, with noxious chemicals and vigilant botanicals where “a fiber stretches from a human to an animal, from a human or an animal to molecules, from molecules to particles, and so on to the imperceptible” (Deleuze and Guattari, 1988: 249); where “a dynamic flow of matter-energy that tends to settle into various bodies, bodies that often join forces, make connections, form alliances” (Bennett, 2004: 365). Dirty needles on the ground in a ruin from some secret junkie history in a Luxembourg crack den we

slept in inspired a terror that those needles had already pricked us, infected us, because part of that place was already inside us. This infectious, perilous engagement is the sort of experience that disappointed visitors to Bodie ghost town may have been searching for, a sort of historical “edgework” (see chapter 4) that pushes right up against the limits of those histories we fear encounter with.

*In August 2009, Marc Explo invited me to undertake an exploration of the abandoned West Park mental hospital in Surrey. We crept through the bushes outside of the site in the early morning, hunting for a window that was not boarded up and when we found one, we crawled through it. As soon as we did, the air thickened. We encountered stacked up tables and chairs behind the front door, obviously intentionally placed there to keep people like us out. As we hunted from one section of the hospital to another, we began encountering more personal places and artefacts. We found a padded cell which we entered and sat in for a while, a place that almost felt like it was bleeding with half-congealed horrors. Next, at a slow and respectful pace, we moved into the hospital's crèche.*

*Marc disappeared down a corridor as I sat down on the broken and bending floorboards, slumped in a pile of decaying toys, wondering where the children who played with them were today. Were they my age? Were they doing okay? As I stumbled across a pair of tiny shoes, I almost had a panic attack. All I could think, over and over to myself was “whose shoes are these”? Soon after, I found a burned doll with mouldy skin sitting in a small chair (likely placed there by another explorer) and stopped to take a photo. The moment burned slowly as the wind whistled through the broken panes of glass and the light in the room slowly shifted with the passing clouds above. It felt like someone had increased the existential volume of the place. Though the history here was spectral on some level and my curiosity perhaps a bit morbid, the impact of that moment was revelatory (Field Notes, Surrey, UK August 2009).*

High and Lewis condemn urban exploration as “analogous to the sport of hunting” and, in regard to one urban exploration website, argue that explorers “say very little about the history, function and physical layout of the [buildings] being explored” (2007: 54). What the authors fail to recognize is that “[memories] don't go in a particular sequence... They are just bits poking up here and there” (Christie, 1992 quoted in Lowenthal 1985, 208), and tapping into them can be more essay than excavation. What is needed is room for experience within inspiration. In their

empirical rationalism, the authors seek to order the disordered, to align form and meaning in places which are in a natural state of rational uncertainty. The disordered spaces they encounter, for them, symbolise a distant landscape and urban exploration a type of sociological dark tourism, consuming without rationalizing as they might prefer.

But what is dark is of course also socially and culturally relative. In many ways, the motivations of the authors to preserve stories, details, locative information and “real” memories is fetishistic and rooted in a Western empirical tradition that also deserves to be challenged. This Western material bias was pointed out to Carolyn Gilman, a material culture curator who was having a dispute with a Native American community over reburial of some indigenous remains. Carolyn was arguing that by reburying them, knowledge might be lost. A community member responded ““why do you white people need to know all this stuff? Why can’t you just let it go?”” Carolyn writes that,

Listening, I had such a visceral reaction of horror, I knew we had hit on something very sacred to *my* culture. The thought of deliberately letting knowledge perish was as sacrilegious to me as the thought of keeping one’s ancestors on a museum shelf was sacrilegious to the Indians in the audience (Gilman quoted in Lowenthal, 1998: 29-30).

When demolition at West Park, the asylum I explored with Marc Explo, finally began in 2010, Patch said, “good, now we can stop photographing that fucking place” (Patch, November 2010). While the statement may imply that Patch didn’t care about the hospital, Winch later told me, as we were standing at the fence around the empty lot that used to be the Cane Hill Asylum,

Look, these places are probably better documented photographically than most heritage sites, it’s sad but we can let them go. There will always be new places to explore, new experiences to be had. And hey, if they turn this into social housing or something, that would be great for the community too (Winch, December 2009).



Figure 47. A child's shoes left behind in the West Park Asylum, Surrey, photo by author



Figure 48. A decrepit doll, West Park Asylum, Surrey, photo by author

Every time you log on to the urban exploration web forums, there seems to be some “breaking news” about one of these derelict asylums around London being demolished. London explorers, some of whom are flippantly called “asylum seekers”, love these asylums for their unique and sad histories, aesthetic and affective qualities and often on weekends you can find multiple groups roaming their corridors taking pictures. The mourning process that they go through when sites are lost (Patch later said he just wanted the hospital to “die in a dignified way”) indicate the deep attachment they have with places, even if they recognize other functions they might serve. A few exploration locations have been turned into squats or smashed up by raves (see Ingham et al., 2007, Townsend, 2010), but those events are mostly celebrated as just another way to participate in what Winch calls “this alternative urban experience” (Winch, September 2011), another indicator toward the underlying liberal politic of freedom and personal responsibility in the urban exploration community (Garrett, 2011c).



Figure 49. The West Park Asylum, Surrey, photo by author

Two years into my research, after the destruction of Cane Hill was complete and West Park was being demolished, I began to consider the seriousness of urban explorer's role as documentarian when these places disappear with little or no formal documentation. I also began to consider, building upon my revelations inside West Park, how the anticipated transience of places affects our experiences while in them, moving our experience of the presented past into an imagined future, where these places no longer exist. Winch, in his free time, maintains a website devoted to the Cane Hill Asylum.<sup>28</sup> The website, which contains many archival photographs as well as Winch's own photos of the place during serial trespasses over many years documenting its slow decay, has received thousands of visits and has earned him thanks from workers and patients of the demolished asylum, who suggested to Winch that neither the National Health Service (NHS) or the government had much interest in preserving its memory. Recently, he was contacted by the British Library with a request to archive the site in its entirety. Despite Winch's admonishment that he was okay with letting the hospital go, he was clearly pleased that the memories of the place would be preserved, placing the urban explorer in the rare role of the well-respected amateur archaeologist/photo journalist.

With rumours swirling about the imminent destruction of West Park at the time Marc Explo and I explored it, reinforced by the loss of the Cane Hill asylum, I considered the fact that this exploration might be my first and last visit to it. Although it was bittersweet, my awareness was heightened, creating an impetus for appreciation, an affectual poignancy, which may not otherwise have been as sharp.

---

<sup>28</sup> <http://www.canehill.org> (accessed 8<sup>th</sup> January 2012).



**Anticipated transience and architectural agency**

“What heresy! To show such zeal over these rotten scraps...”  
 – Jean-Paul Sartre (2009)



Figure 50. Time is happening right now, *Cristallerie du Val Saint Lambert*, Belgium, photo by author

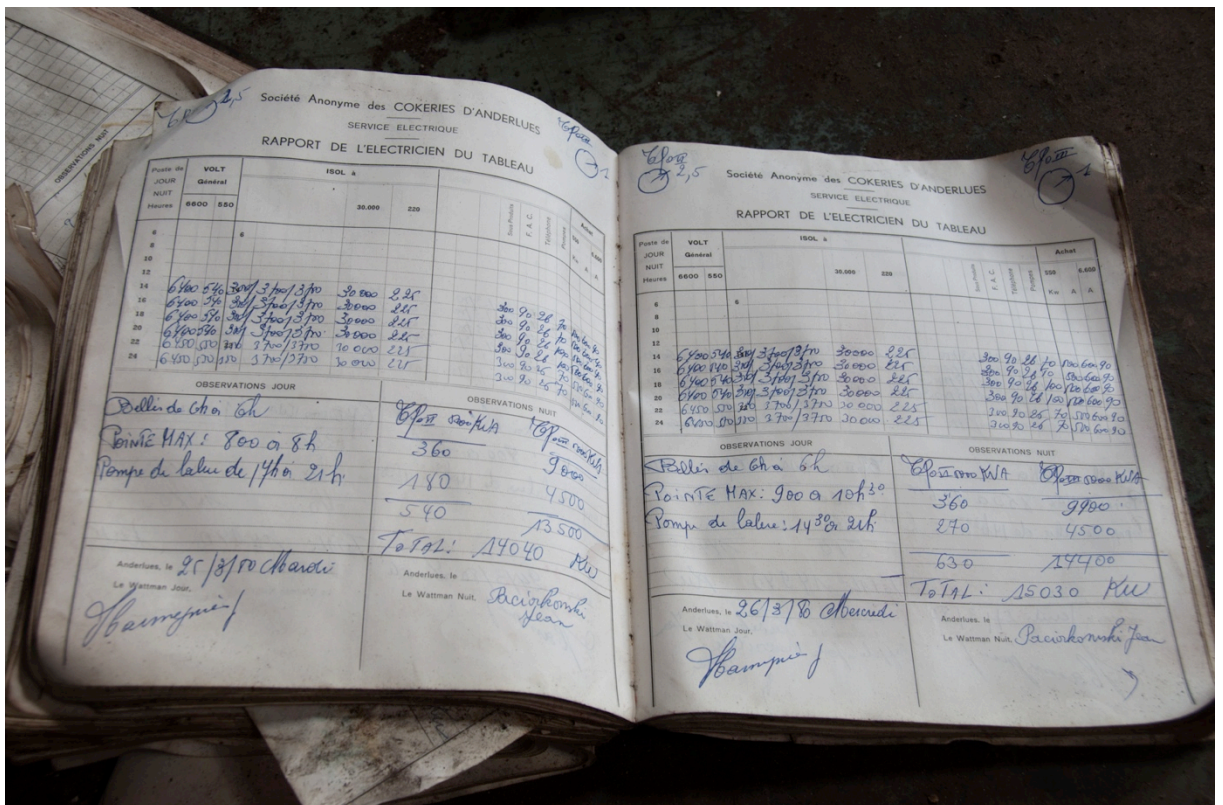

Figure 51. Notes from another time now, *La Cokerie d'Anderlues*, Belgium, photo by author

Caitlin DeSilvey has used the term “anticipated transience” to discuss stretched-out stories, experiences in fragile ruins as braided strands of past, present and future (DeSilvey, 2011). Working linearly through these three concepts, we can first imagine that we go to ruins to read their histories. Sometimes this is actually literal. In my visits to derelict asylums, factories, power stations and military bases, I have found countless ledgers, notepads, pamphlets, medical records and newspapers that gave me personal recollections from employees, dates and story fragments from people who dwelled in these places.

Images of bodies are often conjured up in ruins, particularly by people’s jettisoned clothing and empty chairs. But these artefacts also reveal that these ghosts had minds. Notepads with logs of playtime activities in the crèche at West Park, along with the toys I found, remind us that this was a workplace for some and a site of childhood memories for others. Do these people still live? Do they think of this place? Are their memories inscribed in the walls, peeling off with the puke-coloured yellow lead paint? Would these artefacts that I am photographing be important to them? Remnants of edible rubbish dragged around the place indicate a non-human architectural life just as vibrant. These are the affectual qualities of the materiality that Reyes described earlier, the need to pull meaning out of “stuff” “marinating in fetid stillness”. Through DeSilvey’s meditation on anticipated transience, in combination with my shared experiences with urban explorers, we experience “memory materialised in the body, in movement, it ceases to be pure memory: it is lived in the present” (Game, 1991: 97).

In this past informed present, we might begin to think about our experience, not in contrast to, but interwoven with, these residual emotions and fleeting memories.

We go to these places to attempt to read the inscriptions, to have bodily encounters that challenge or reconfigure our conception of everyday experience and to eventually begin writing ourselves into places by photographing them/photographing ourselves in them. But we can also imagine the tendrils of emotion that we leave behind, the shared moments of fear and excitement that are left floating in corners like twisting smoke in a room full of stagnant air. A security guard on site at West Park told the Badman, another of my project participants, upon catching him in the ruin that “every time he enters the asylum, he says a prayer” (Godwin, 2010). This everyday ritual goes beyond the materiality of the site, though it also reinforces the agency of place by reifying its ability to relay meaning in the present with or without human interpretation, knowledge of the formal histories of the location, or even our presence.

Part of our enjoyment of these places is clearly a regard for their mutable qualities – every time we go back to a place in decay, it is different. The *how* is many times unknown. An explorer moved an old typewriter a centimetre to get better lighting on it for a photo, some youth tagged the walls up, a group of kids had a party here, a security guard put up a new board on a window, a fox dragged the outside in, the rain finally saturated the roof beams to the point of collapse. We get glimpses of nature doing its slow but relentless work, ivy creeping though the windows, mould taking down the walls, trees pushing through the floorboards, rain slowly picking at the roof tiles.



Figure 52. Whittingham Asylum, Lancashire, December 2007, photo by Winch

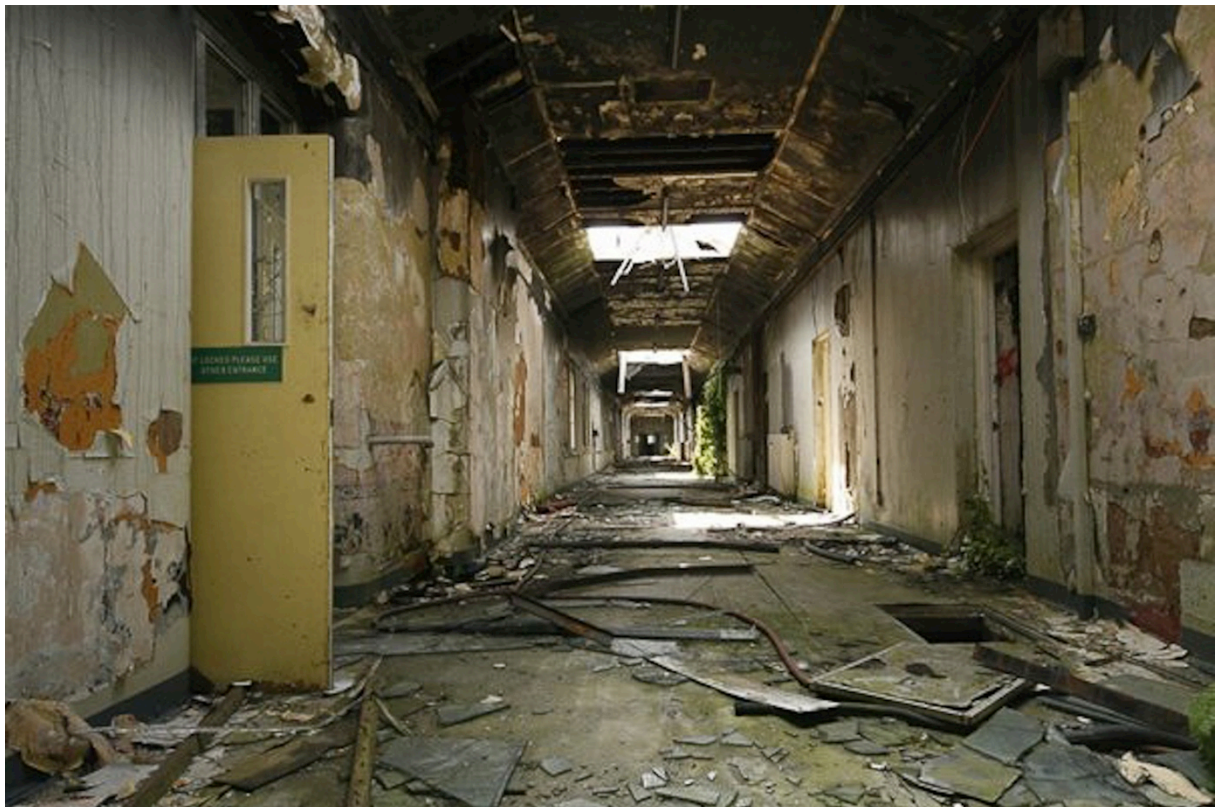

Figure 53. Whittingham Asylum, Lancashire, July 2009, photo by Winch

Our excitement registers when we see and feel these changes; we imagine a future memory forgotten, anticipate the inevitable transience of existence – not just ours but the buildings, leaving us “haunted by the threatening aura of ruins, by their oppressive interlocking of past and present, nature and culture, death and life” (Huyssen, 2010: 26). Anticipating transience gives us an image of ourselves written into this decaying future memory, a glimpse of our footprints in the dust, as we muse about what would have been missed if we hadn’t been brave enough to take that first step into the “unknown” and the “frightening”.

This is what I argue urban explorers have to teach those who look after interpreted historic spaces and managed heritage sites dutifully maintained in a state of arrested decay – something is missing where we cannot anticipate the transience; where material and memorial trajectory is regulated. We cannot see ourselves written into their futures because we are not “allowed” to inscribe them. The act of preservation of a ruin, if the intention is to preserve the aesthetics of decay (Trigg, 2006), is ultimately self-defeating because the essence of that decay is lost with the effort to stall it (Roth, 1997: 8).

We can’t dance with arrested decay because it’s a corpse. We also can’t save every place and preservation is not always the best option. Ruins appreciated for their beauty in the present, combined with a feel for their role in an ephemeral past, activate places because they are recognized as living, breathing sites of memory and experience. Arrested decay is misinterpreted love for ruins when it becomes nostalgic for a cryogenically frozen past. An embodied, living history begins not with the site but with the visitor, whoever or whatever the visitor might be.



Figure 54. Stepping into the unknown, St Josefsheim Monastery, Germany, photo by author



Figure 55. Sleeping in Soviet base Vogelsang, Berlin, photo by author

*On the 25<sup>th</sup> of April, 2009, LutEx and I went to explore Severalls Asylum. After sneaking through a hole in the chain link fence, we ran into 4 other explorers inside the main gate, still in the courtyard looking for a way over the palisade fencing. This was the day I met Dangerous Dave, Patch and Statler.*

*The 5 of us found a ladder in one of the periphery buildings and Lutex took the lead on putting the ladder over the fence so that we could all safely climb over. What was a frenzied pace, once inside, immediately slowed down and everyone walked quietly from the beautifully decaying admin building to the burned out x-ray wards, at one point running when someone spotted a high-vis vest hanging in a room they thought was a security guard. At the end of the day, after filming and replaying the days events as we all laughed in the car, Dangerous Dave said "I think it's great you're filming this stuff so people get an idea of what it is we do, not just what we produce." On the train ride home, Patch and Dave ran off with little notice to explore another hospital they knew was in the area that still had on operating table they could lay on (Field Notes, Colchester, UK, April 2009).*

High and Lewis, in *Corporate Wasteland*, correctly recognize that the distance that leads to "tourism" begins with the body in place, with sensory experience (Edensor, 1998) and that memories can also be built from the present, but then go on to separate the present from the past, situating the liminal zone of crossing at the border of the ruin, contending that "to enter an abandoned site is, in some small way, to cross an imaginative divide separating the perceived post-industrial present from the industrial past" (High and Lewis, 2007: 58). When I asked Winch about this distinction as we walked though the abandoned Soviet military base "Vogelsang" in Germany at the tail end of our first 7-day urban camping road trip, he recognized the liminal boundary of the ruin as a place of imposed spatial distinction but refuted the temporal divide asserted by High and Lewis. He told me that a building's closed life, its afterlife, was just as much a part of its history as its open life or working life and that these phases both contradict and complement each other.



Figure 56. The post-industrial present? *Cristallerie du Val Saint Lambert*, Belgium, photo by author.



Figure 57. A continuing life of heavy industry, *Schwermaschinenbau*, Germany, photo by author



Winch's proposition, interestingly, gives the architecture agency and recognizes that the building, although it has a human history, continues that history after the point of abandonment, with or without our presence, the presence of homeless people, drug users, graffiti artist, geocachers, squatters, film crews, security guards or troupes of children looking for imaginative play space, though these components almost always *do* exist. Winch's primary distinction between the phases of a building are based on its use value in terms of capital function *and* recreational function, both of which are overlapping, neither of which is prioritized or necessary for the building's life or significance. We may appreciate, ignore, despise or even destroy the ruin, but the ruin continues, with or without us (Weisman, 2007).

As I have demonstrated, the urban exploration community many times protects the fragile derelict materiality of sites by minimising impact and not disclosing their locations so that these mutations can endure, so those secret histories continue to be revealed in whispers and through spontaneous embodied discovery, acting as safe keepers of extraordinary affects in a world rendered increasingly mundane. The constant exploration, discovery and re-discovery of the urban environment betrays the fact that material culture is a renewable resource (Holtorf, 2005). Urban explorers constantly rework this resource by assaying histories in new and unexpected ways that inspire a past open to rewrite and contestation where "all time - past, present and future - coexists simultaneously" (Borges, 1971: 189). However, they also protect the sites as reservoirs of affect to be tapped as needed based on accumulated esoteric knowledge. Becoming safekeepers of that rare knowledge can, of course, contribute to the elitist attitudes of explorers, where they live out personal heroic fantasies in strange places.

**Post-human imaginaries: mortal architecture**

“The ruins of a now outlived urban dream revealed, more clearly than ever before, the phantasmagoric nature of the artefact and the hidden scripting of their making.”

– (Kaika and Swyngedouw, 2000: 132)



Figure 58. Author at the post-apocalyptic Burton Brewed Bitter site, London, photo by author

As I wrote in chapter one, while urban exploration appears novel in its global cohesiveness or community aspects, the practice itself is not. Romantic accounts of ruin exploration in the last 2000 years abound. As we anticipated their transience, ruins, like dreams, pull us, in one direction, toward our innermost yearnings and, in another, towards a life beyond the constraints of the real (Pile, 2005: 29). Clearly part of our attraction to derelict space also has a darker component of an imagined ruined future, a Ballardian formulation of urban apocalypse (see videos 5, 6 and 7, *Hoboemia Triptych*).



Figure 59. Imagined ruins of John Soane's Bank of England, by Joseph Michael Gandy (1830), image via Wikimedia Commons

Many 18<sup>th</sup> and 19<sup>th</sup> century depictions of ruins were built around the ethos of artists such as Robert and Panini who painted European dereliction with a healthy dose of nostalgic romanticism. Famously, in 1830, the artist Joseph Gandy was commissioned by John Soane, the architect of the Bank of England, to create a painting of what the bank would look like in ruins before it was built. Later, Hitler's architect Albert Speer wrote the *Theory of Ruin Value* (see Speer, 1970) in which he sought to manufacture the greatness of the Third Reich through the construction of buildings which would decay beautifully. Speer was assisted by the political geographer Karl Haushofer who insisted that German imperial imaginary would be bolstered by "ruin gazing" (Haushofer, 1934 quoted in Hell 2010, Stead, 2007). These representations have deep connections to people's perceptions of what the "use" of ruins might be, an imagination that retains an Imperial taint. These examples, despite not being necessarily common knowledge, have served as models for many contemporary perceptions of ruin aesthetics (Trigg, 2006). The result is a situation in which, following from the writings of Walter Benjamin

(1998) “the metaphorical power of ruination is as relevant today as it was in an ostensibly more Romantic era” (Rapp, 2010: 20).

Nietzsche contends that this type of nostalgic longing is emotionally crippling, creating a society so rooted in preserving some legacy of itself that it fails to appreciate moments of existence in the present; present moments are lived through a lens of historical consciousness. As a result, Nietzsche quips that “every past is worth condemning” (Nietzsche, 2006: 21). Slightly less polemically perhaps, I suggest urban exploration offers an important model for intersections of historical encounter, present-day experience and post-human future imagination. As Ninjalicious (1997: 2) argues, in that post-apocalyptic future, what we need are not wilderness survival skills but “urban survival skills. Fence climbing. Lockpicking. Breaking and entering. Wall scaling. Trap detection. Building navigation. Hole avoidance. Where better to foster such skills than in abandoned buildings?”

Paul Dobraszcyk writes of a trip taken to the exploded nuclear reactor at Chernobyl which “incorporated elements of both dark tourism and urban exploration” (2010: 372) as he searched for what Susan Sontag referred to as confrontations with “inconceivable terror” (Sontag, 1965: 52). Dobraszcyk writes, “coupled with a century or more of apocalyptic visions of ruined cities in literature and cinema and a recent emphasis on realistic visions of urban destruction in many post-apocalyptic films and computer games, the links between real and imagined ruination are becoming increasingly blurred” (Dobraszcyk, 2010: 371, reading Davis, 2002: 5).



Figure 60. Silent Motion and Marc Explo in the urban training ground, *Wolfsschlucht II*, near Paris, photo by author

This imagination, as Dobraszczyk found, is an undeniable part of the allure of urban exploration, normally tied to cold-war imaginaries. We can find resonances in the writing of W.G. Sebald where he explores the derelict Orford Ness military installation:

...the closer I came to these ruins... the more I imagined myself among the remains of our own civilization after its extinction in some future catastrophe. To me too, as for some latter-day stranger ignorant of the nature of our society wandering about among the heaps of scrap metal and defunct machinery, the beings who had once lived and worked here were an enigma, as was the purpose of the primitive contraptions and fittings inside the bunkers, the iron rails under the ceilings, the hooks of the still partially tiled walls, the showerheads the size of plates, the ramps and soakaways (Sebald and Hulse, 1998: 237).

Jonathan Veitch (2010), in the compilation *Ruins of Modernity*, tours the Nevada Atomic Test Site where he finds not the expected response of melancholy or nostalgia upon entering the ruins but Baudelaire's Satanic laughter, a terror that is

so visceral the only possible response is humour, as if the emotions have been short-wired by the horror.



Figure 61. Urban exploration often reveals the disturbing, The Horror Labs, Belgium, photo by author

The experience of being overwhelmed by the environment or situation that is clearly “out of control” is becoming less and less prevalent in a society which prides itself of maintaining order, as youliveandyouburn wrote in chapter 1, which robs the individual of agency over their existential trajectory in the same way that regulation of ruins many times precludes the possibility of writing our own stories into them. Yet despite losing control over actions on a everyday basis, Lyng (1990: 873) writes that “as several scholars have noted (Lasch, 1978, Erikson, 1976), increasing numbers of people in modern postindustrial society feel threatened, both physically and mentally, by forces entirely beyond their control, for example, threats posed by toxic chemicals in the environment, nuclear war, financial instability, the general instability of personal relationships, and so forth”. And so,

developing an embodied situational tactic for coping with a dystopic future imagination, developing the proficiency of the self and community to persevere in the face of utter catastrophe, seems a logical extension of the inability to cope with modern society.

In Clapham, South London, there is a system of deep shelters, three in total, under Clapham South, Clapham Common and Clapham North Tube stations. We systematically gained access to each of these shelters and explored them as a group. The crew also held a leaving party for me in one of those bunkers when I left to write up. At the party, Statler joked with me, saying, “if there’s ever a nuclear attack or something, I know where I’m headed.” Drainpipe, who I brought with me to the party, told me “I’m staying close to you, you clearly have the keys to the city” (Statler and Drainpipe, February 2011), implying that in an event of a disaster, I would know just where to go. Feeling that I had this “insider” urban knowledge was empowering. This process of empowerment though living out fantasy is written about by Marc Explo on his blog *Ejectable*,

As a kid I used to watch superheroes, detectives, and undercover agents on TV. Then, as a teenager, video-games got me involved deeper into these virtual adventures. In comparison reality was dull. It wasn't my fault, I was in the wrong place at the wrong time: unbelievable stories always happen in the past, in the future, or in parallel universes. My only hope was to become a cop or a secret spy. I took an office job. It was less exciting but sounded like a safer career plan. Years later, I had nearly surrendered my dreams when I stumbled upon a few individuals who refused to let adventure die. Since I joined them my life hasn't been the same and there's no way back. We climb churches and bridges, we infiltrate into buildings from the service tunnels underneath, we throw parties underground and at the top of high-rise towers. We have superpowers.<sup>29</sup>

---

<sup>29</sup> <http://ejectable.net> (accessed 12<sup>th</sup> January 2012).



Figure 62. The author descending into the Clapham South bunker, London, photo by author





Figure 63. The author inside the Clapham North bunker, London, photo by author

Thinking back to the discussion in chapter 2 of demographics, involvement and exclusion within this practice, a critical reading of Marc Explo's description of how he got involved can quickly become problematic. His comments suggest that his desire to explore was a reaction to middle class boredom. Perhaps as well, it is a very boyish, childish desire for adventure that compels him to explore. Finally, he appears mildly delusional over what he may accomplish through urban exploration. Looking back over my images included in the thesis, similar critiques can be made of my photography, particularly Figure 63. Am I here attempting to replicate the culture under study or a victim of my own delusion?

Clearly part of the reason explorers enjoy sneaking into decaying architecture is rooted in an imagination of a post-apocalyptic future. These places are viscerally enticing in their wretchedness, in part, because imagining ourselves populating them during futures filled with heroism and adventure (here again the daring male questing for authenticity of experience) is so improbable that it forces one

to meditate on the surreal nature of the past that has led us to this most improbable junction in time. Writing of Pripyat, one contributor to the new book *Beauty in Decay* which represents these sites with burning gothic intensity notes that Pripyat “continues to whisper of a ‘post-human’ earth which, in the end, may be the strongest fascination of them all” (RomanyWG, 2010: np).

In our explorations of the ruins of Eastern Europe between 2008 and 2010, we all took guilty pleasure in witnessing the remains of the failed Soviet Union (Lusito and Conte, 2009) and Nazi Germany, reacting, at times, absurdly to it as I did at Nohra when I assaulted the Lenin statue. The experience left us in a distinctly different state than ruin exploration in the United Kingdom, the reverence for actual state failure (rather than imagined post-capitalist or “site-specific” failure) making our explorations both more poignant and more guilt-ridden (see video 10, *Crack the Surface*, 14:20). If, as Dylan Trigg writes in *The Aesthetics of Decay* (Trigg, 2006), a derelict factory testifies to a failed past but also reminds us that the future may end in ruin, what does the ruin of a failed state say to us?

Henry James (James, 1968 [1909]: 222) writes in *Italian Hours*, “to delight in the aspect of the sentient ruin might appear a heartless pastime, and the pleasure, I confess, shows a note of perversity”. This perversity takes on a different form as you leave “home”. The nostalgia wears a dark mask of exotic fetishism that beckons the days of Empire, even surrounded by the possible beginning of the end of capitalism and the nation state at home. Of course, these expeditions are markedly less decadent than those of ages past but even speaking English marks us as a potentially dark and exploitative party even as we seek to avoid being “tourists” by following Steve Pile’s advice that “in order to get at some of the real (really operative) processes in city life, attention should be paid to those things

that appear marginal, or discarded, or lost, or that have disappeared or are in the process of disappearance“ (Pile, 2005: 48).

In explorations of subterranean features such as utility tunnels, catacombs and bunkers like the ones in Clapham, there is a fantasy being played out of someday taking refuge here. Whether from drought, famine, nuclear attack or a zombie infestation is never articulated, yet it's often implied that this sort of scenario would almost be a blessing, the explorers could then exert the full force of their knowledge and skills; they could finally be the heroes they believe they are.



Figure 64. Almost forgotten, University of Liege, Belgium, photo by author

As Leary (2011: np) writes, these ruins appear to be “a potent symbol of decline and the inevitable cycles of capitalist booms and busts.” Susan Buck-Morss writes in *The Dialectics of Seeing* (1991: 164) that throughout Benjamin’s *Arcades Project* (1999), “the image of the ‘ruin’ is emblematic not only of the transitoriness and fragility of capitalist culture, but also its destructiveness.” Imaginations are bolstered by the thought we are seeing ghosts from a future yet to come (Pile,

2005). In exploring the ruins of a failed past after hearing the stories of workers being shut out of factories after 30 years of dedicated corporate service (Cowie and Heathcott, 2003: 15, also see Milkman, 1997), explorers don't just experience that surreal collapse of time and space that exist within the ruin – they remind themselves that everything is transience and that anything we think we can hold onto is illusion (DeSilvey, 2011).

Perhaps, on some level, this creates apathy toward history that can be translated as memorial disinterest, or even generational selfishness, but it also reminds explorers that we must take responsibility to prepare for the next inevitable economic failure. Derelict site location knowledge and access acts as a post-apocalyptic insurance policy.



Figure 65. Marc Explo, Statler, Silent Motion, Winch and the author sleeping in the quarries of Paris, photo by author

Urban explorers are largely ambivalent about national economic prosperity – however, as I have mentioned, there is an identifiable strain of libertarianism throughout the community, connected to the notion of personal responsibility for risk-taking (High and Lewis, 2007: 61, RomanyWG, 2010: np). Explorers enjoy the excesses of capitalism, the construction, the development, the spoils, yet also celebrate economic and capital failure by exploring ‘ruin’ space and by imagining themselves as the keepers of secrets that would put them at an advantage in a dystopic future. While this would technically be the case, given that explorers know intimately the infrastructural networks of cities, including places like nuclear bunkers, and have access to these places in a way the general populace does not, urban explorers also like to imagine themselves as being more heroic than they are, as if being gatekeepers to that information already makes them postmodern superheroes (thinking back to Marc Explo’s post). Of course, given the surreal nature of the experiences explorers have, some of which I have described, it may not be shocking to imagine the lines between fantasy and reality in the practice often become blurred and my blog, over the course of the project, became a perfect example of that delicious delirium.

These future dystopic, post-climate catastrophe and/or post-apocalyptic imaginaries are evident all over popular culture, from films like *Mad Max*, *28 Days Later* (which the UK urban exploration forum is obviously named after), *12 Monkeys*, *The Postman*, *A Boy and His Dog*, *The Book of Eli* and in novels like *After London* (Jefferies, 2010 [1885]), *World Made by Hand* (Kunstler, 2008), *The Road* (McCarthy, 2006), *Earth Abides* (Stewart, 2006 [1949]), *The Stand*, (King, 1986) or *The Plague* (Camus, 1991) and even in video games like *Bioshock*, *Silent Hill* and *Rage*.



Figure 66. The author commandeering a disused military vehicle in a former NATO bunker, near Paris, photo by author

In all of these depictions, though the future may be bleak and dystopic, there is some underlying euphoria behind the freedom that comes with being released from the state, social life and cultural expectation that has an obvious relationship to the off-the-grid spaces that urban explorers go into. Dsankt, when I raised the issue, disagreed that urban explorers were anywhere near “off the grid”,

*...to me the typical urbex experience and the life of someone living off the grid only overlap in their location. Most explorers I know are middle class, work 9-5 or study, have a phone, car, bank account, maintain an internet presence, pay rent etc, all things attaching them heavily to the grid. It's their/our position and wealth on the grid which allow us to treat these places as a playground and participate in this decay tourism, rather than see them as a means to an end - survival. It's something heavily discussed on a recent trip through the Balkans... where we passed through and treated areas of suffering and poverty like playgrounds. In retrospect I feel a little guilty for taking pictures of the decaying husk of a concrete factory which the current inhabitants utilise to store farming equipment they use to scratch out an existence. A life which in western Europe would be considered very poor. Momentarily stepping off the grid to satisfy our desire for a taste of the other side is a tiny step compared to what's needed to shift our perception of these places from ones of recreation to ones of shelter and survival, and answer all the other questions that come with giving up a life on the*

*grid. It's a very romantic notion and one I loved during the time I was squatting but I never considered myself to be off the grid, I was both connected to it and dependent on it. The homeless guys I passed everyday who slept on the street were off the grid I guess, but were still reliant on it for they dug in the trashcans and took donations from others. Can you imagine your average urban explorer selling their prized DSLR to buy a load of bread, or a tent for the winter when they're forcibly evicted from their squat?<sup>30</sup>*

Dsankt makes important points here – perhaps our imaginations of these dystopic futures just feels like they are becoming increasingly realistic as our faith in the state to take care of us is eroded; as we see the world collapsing around us politically, environmentally and socially (Fukuyama, 1992) and if we actually had to deal with a state-level failure, explorers would not find themselves at any sort of advantage. Now that may be obvious. What isn't obvious is that explorers like the idea to some extent. Many explorers want society to implode, to see how they would fare in a world not regulated by health and safety, to see what might be achieved when confronted with the most basic challenges of finding food, water, shelter, defence and community.

I argue that the urban explorer's interest in post-apocalyptic imaginaries is nothing less than an interest in trying to get back to what we have lost in late capitalism, a sense of place, a sense of community, a sense of self – as Marc Explo tells me, “we want to be a part of a tribe again, where relationships matter” (Marc Explo, October 2011). And although urban exploration passes through places rather than staking them out in any permanent way, it can also act as a vital bridge, a gateway, because it finally makes the move from imagination to action. When we explore, we take a small step off the grid. Perhaps it is only one more to start peeking into that other side that Dsankt mentioned.

---

<sup>30</sup> The full conversation can be accessed at <http://www.placehacking.co.uk/2010/11/16/urban-apocalypse> (accessed 16th November 2010).

**Temporal junctions: the past and imagined future in the present**

“You should create your own icons and way of life, because nostalgia isn't glamorous... live your life now.”

– Marilyn Monroe, Press Conference, Hollywood 1956

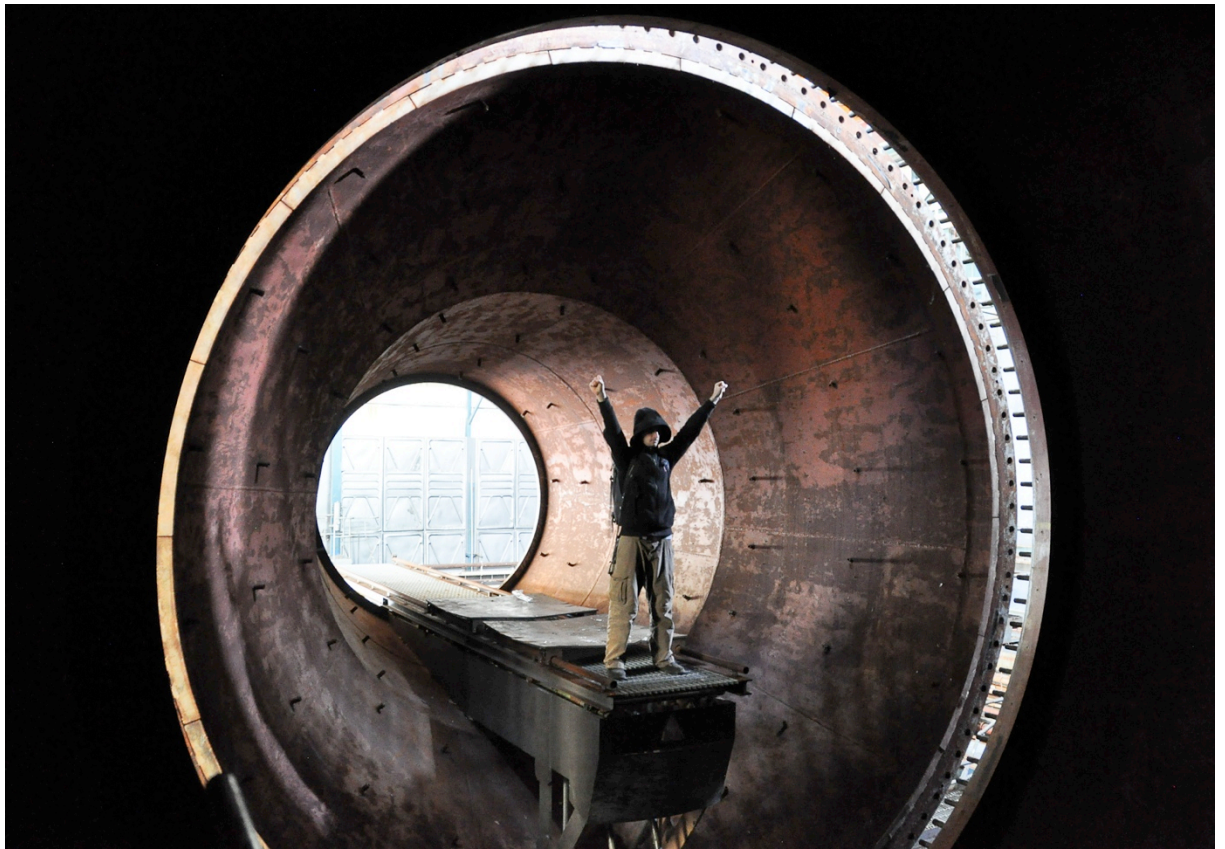

Figure 67. Marc Explo in NGTE Pyestock, Farnborough, photo by author

In this chapter, I have shown that urban explorers are interested in quarrying spontaneous finds through embodied experience in derelict and abandoned places to create enticing embodied temporal juxtapositions. I have shown that urban explorers are aware that “each time we enter a new place, we become one of the ingredients of an existing hybridity...” (Lippard, 1997: 5-6) and are prepared to care for historic sites and to let them disappear at the same time they might imagine residing in rather than passing through them. Again, I am not implying that one view of the past is more important or more significant than another. What I want to argue is that there is a place, a need and a desire for embodied experiences of the past, dreams of alternative pasts, for localized historic interpretation and for unregulated decay because “a ruin can point much more



powerfully than a restored building to its historical and social genesis” (Steinmetz, 2010: 317) and because unregulated experiences in ruins tell us as much about ourselves as about the places we explore.

I have also demonstrated that in these explorations, stories of places are constructed through interaction with the materiality, myths and dreams of places experienced, on personal, sensual, memorial and aesthetic terms, folded into the multiple narratives of our social lives, the lives of those who have come before us and the lives of those human, non-human, ghostly and architectural entities also involved with sites of past, present and future memory. Regardless of the eventual fate of the places themselves, by understanding places on terms of our choosing, we have the opportunity to construct rich, lively, ever-morphing narrative encounters that collectively begin to complicate and transform the ways in which we respond to urban space and our understandings of the values of places.

Ruins may be decaying but they are not dead, they are places filled with possibilities for wondrous adventure, inspiring visions, quiet moments, peripatetic playfulness, dystopic preparation and artistic potential. We could of course take this sense of aesthetics, these small stories, these dark memories and darker imaginaries and fold them into a larger narrative about the historical significance of these places. But I would also suggest that we reconsider the possibility that ruins have agency beyond representation and human engagement, they are sites for performative events, encounters between beings, places where material and immaterial, human and animal, animate and inanimate begin to fall away. Although they might be partially subterranean, trapped in some measure and protected in an archaeological soil matrix, in many cases they're not; they sit on the earth,

exposed to weathering elements that constantly assault them and mark their surfaces with smoothness and striation that cannot be artificially produced. As these assaults begin to morph them, their narratives of capital “progress” begin to peel back to reveal a skeleton of rust, cogs, switches, dials, utility tunnels, circuit boards, and mouldy pieces of paper outlining modes of production, things to remember, forgotten photographs and festering memories, indicating an iterative architectural formulation has begun yet again, perhaps one that even lies outside the fertile imaginations of urban explorers. When we pass through these places, we tap into those multiple mutabilities, revealing the slipperiness of our own existence as much as theirs.



Figure 68. Slippage at the abandoned University of Liege, Belgium, photo by author

This slippage between signifier and signified is where Derrida (1981) finds meaning, in the complicated intersections between what we expect and what we find in what we might call a hauntological moment. Nowhere is this truer than in ruins which are inherently spectral due to their temporal and spatial disordering

where “the spectral above all confounds settled orders of past and present. Spectrality effects in place, and differentially in different placings, an unsettling complication of the linear sequence of past, present and future” (Wylie, 2007: 172).

Exploring ruins reveals a different temporal pace and scale that challenges us to increase our awareness, concentration and participation. Through these explorations, we enter an intensely emotional courtship with place. The meaning, the desire, built through those courtships is something that shouldn't be underestimated, it festers and ferments into a geography of love (Wylie, 2009) folded right back into the fabric of places to be discovered and rediscovered, the explorers and the explored both becoming revenant. In essence, as Holloway and Kneale (2008: 303) write, “what we are dealing with when a space becomes haunted is the disruption or dislocation of normalized configurations and affordances of materiality, embodiment and space.” Urban explorers, while searching for ghosts, also become spectres on the margins.

Urban exploration experiences pasts in what might be unexpected ways. As I have shown in this chapter, practitioners are interested in small stories and local, immaterial, fantastic and whimsical histories. The practice does not exclude dark pasts and does not (usually) shy away from destruction and loss of the places that these stories are found in. Exploration also fosters an imagination of the past and experience of the present informed by a cautious curiosity about what the future may hold as people begin to lose faith in current government and financial systems. Perhaps this the reason the practice is taking on a rapidly increasing social relevance, as people become more curious about what a post-capitalist world would look like – urban explorers can supply those imaginative depictions.

Most importantly though, I hope to have shown that while urban explorers may appear naïve, superficial spectators or an exploitative groups of privileged teenagers, they are also temporal alchemists, undertaking (at times) important documentation and churning the past, present and to some extent the future, into new and exciting forms that I believe we can all learn from.



Figure 69. Time churning, *Barenquell Brewery*, Berlin, photo by author

In the next Chapter, we move increasingly from places of history into places of fear and excitement. During 2010, London “Team B”, after our urban camping road trips in Europe and “rinsing” of derelict locations in and around London, largely moved on from ruin exploration into infrastructural infiltrations of London’s drain and utility network, cranes and skyscrapers, and eventually the London Underground and underground government installations. As we did so, our geographical imaginations underwent a radical vertical reconfiguration, even as our skills grew alongside our expectations of what was possible in the city.

## Chapter 4 – The rise of an infiltration crew

“What you can do or think you can do, begin it. For boldness has magic, power and genius in it.”

– Johann Wolfgang von Goethe (1909: 20)



Figure 70. Jules in the Clapham North Bunker, London, photo by author

The global community of urban explorers, as much as there is one, generally ascribes to the unspoken “code of ethics” I outlined in chapter 1, recording and often defending marginal and ruin space to preserve the types of experiences described in chapter 3. However, in this chapter, I discuss the ways in which particular urban explorers and groups of explorers rise to prominence by, predictably, being the first to explore “new” and elusive locations and by undertaking the most difficult and often dangerous explorations of urban environments, striving for the discovery of what urban explorers call “Holy Grails”. Often, in order to obtain “Grails”, the code of ethics has to be bent to particular needs. Many of the world’s most well-respected explorers often find themselves at odds with “forum communities” when the desire to reveal new locations surpasses the desire to seek community approval, causing social fracturisation.

### **The tipping point – cracking the Ministry of Defence**

“There is no one hacker ethic. Everyone has his own. To say that we all think that same way is preposterous.”

– Acid Phreak (Coleman and Golub, 2008)

*At the beginning of what was to be a long, cold winter in 2009, we received information that a Ministry of Defence (MOD) nuclear bunker underneath an active military base in Corsham, Wiltshire, had been breached. Eight of us arrived in two cars that night to be directed by a local explorer called Tommo in the appropriate direction. We passed our bags through a hole in the gate to Spring Quarry, an abandoned system which, we could see from maps Patch had obtained, abutted the underground MOD base.*

*We worked for hours into the night, checking the walls for newly dug tunnels to gain access to the bunker, finally coming to the conclusion that the only entrance was through a massive blast door that was sealed tightly. Either we had been given bad information or the bunker had been re-sealed in between the time we received it and our arrival.*

*The eight of us took a brief moment to discuss our options. If we were to subscribe to the UE “code of ethics”, this trip would be over, finding no entry that didn’t require force. If we forced the door, we could never speak about it or face social banishment. We had had come to a crossroad that, I would later realise, would change the way our crew*

*operated forever. We voted to pry open the blast door. As the ethnographer for the group, they were particularly sensitive about my feelings on the issue. When I agreed I would participate, they asked if I would be happy to not film or write about how we gained access. Again, I agreed.*

*We found two large metal bars in the quarry and two of us wedged them into the blast door at the top and bottom. Applying pressure to the door, we finally moved it back from the wall enough that we could unscrew the large wingnut on the back that was holding the door shut. The wingnut fell to the ground along with the two explorers prying the door and it flew open with a rusty scream. We stood in front of the freshly cracked Ministry of Defence bunker in plain view of a very large security camera. A panicked discussion ensued. Figuring we had already been seen and praying that no one was actually watching the cameras (often the case), we pulled masks over our faces and pushed forward into Burlington, the UK government's underground city, all scared witless but determined to reveal what was inside.*

*What was contained within Burlington was not just a fantastic material discovery, it was a reconfiguration of our boundaries as explorers. We had breached the UE code of ethics to gain access; when we found a set of electric carts in the base we decided to push it further. We hotwired them and drove around all night long, skidding around turns, taking photographs and laughing, everyone terrified and utterly drunk on the terror. It was not night the Urban Infiltration Scene was born; the night Team B went pro. (Field Notes, London, December 2010 – written after Burlington went “public”).*



Figure 71. The first steps into Burlington bunker, Wiltshire, photo by author

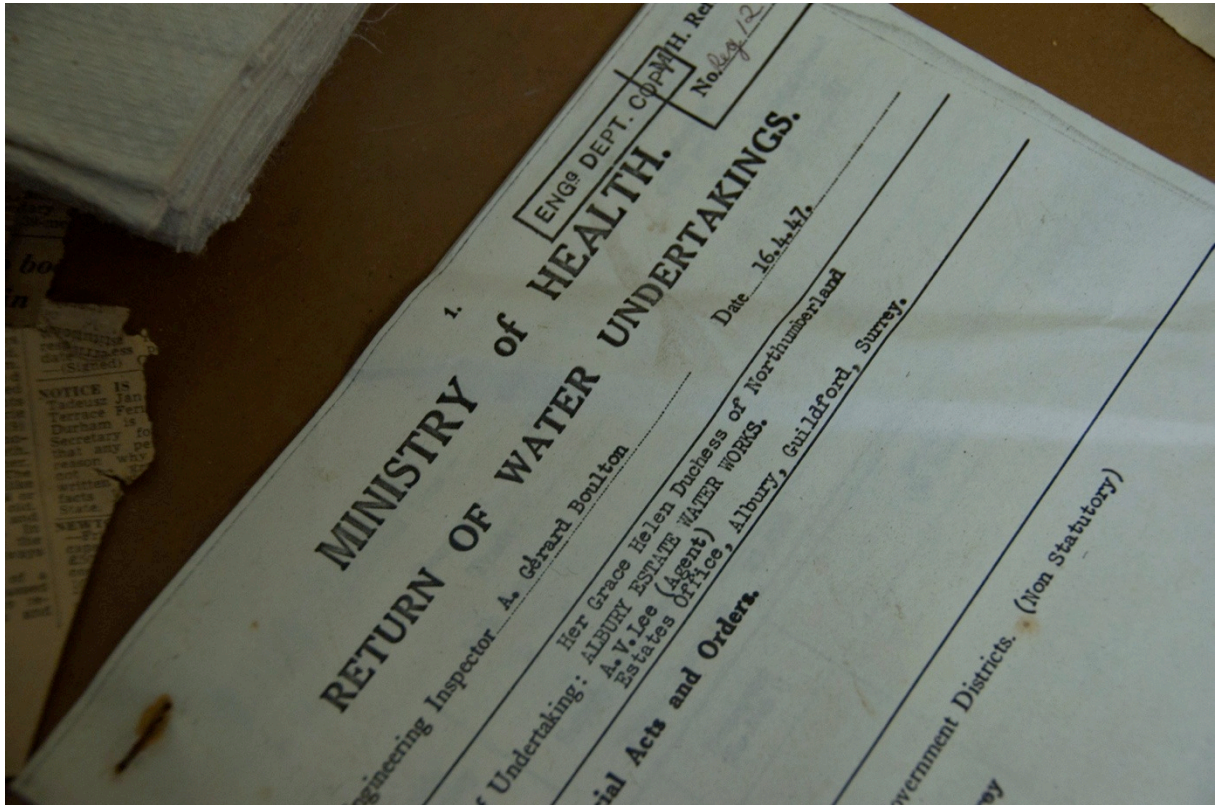

Figure 72. Burlington was an archaeological treasure trove, our personal museum for a night, Burlington bunker, Wiltshire, photo by author



Figure 73. Team B reviewing maps, planning our exploration of Burlington bunker, Wiltshire, photo by author



Alan Rapp writes that the practice of urban exploration “provides a tart reminder that the areas that we have regular access to are not just quotidian, but also normative, if not repressive. The patterning that we can infer from the sanctioned environment is absent from the spaces that urban explorers go; they have been deprogrammed” (Rapp, 2010: 31).

In the same way the “the techniques *dérive* and *détournement* offer the possibility to explore spaces in new ways, and to rearrange existing aesthetic elements into new forms of expression” (Barnard, 2004: 114), urban exploration also fits Alastair Bonnett’s description of offering “a new form of geographical investigation that can enable the revolutionary reappropriation of the landscape” (Bonnett, 1989: 136), even if this reappropriation lasts only for a night, as it did in Burlington.

As I pointed out in Chapter 3, there is a strong strand within mainstream urban exploration of righteous preservationism – a sense that without the help of urban explorer “documenting” these places, they would slip into eternity without notice. Behind the scene though, as we eventually found, almost all infiltration and exploration of “new” locations builds on the back of those willing to transgress the “code” or reliance on somebody else (kids, graffiti crews) opening a location so explorers can follow.

Although every explorer is aware this is, or at least may be, the case, it is largely not to be spoken. As Oxygen Thief, the administrator of 28 Days Later wrote in a thread on the forum,



Figure 74. Silent Motion, Neb and Statler figure out how to start the "Burly buggies", Burlington bunker, Wiltshire, photo by author.



Figure 75. A temporary public reappropriation of military resources, Burlington bunker, Wiltshire, photo by author.

Everybody from the DP (Dark Places) / early 28DL (28 Days Later) days knows the score. We just decide not to say anything and toe the public image line. It's the HDR kiddies and noobs that don't know what really happens out there (Oxygen Thief, November 2011).<sup>31</sup>

Two months after cracking Burlington, I prematurely posted the photos on my blog.<sup>32</sup> At the time, I said that it was a rash decision made in drunken haste. It wasn't. I wanted to test the boundaries of individual freedom within the community and to probe the power of the supposedly informal "code of ethics". Essentially, I wanted to know who would attempt to enforce it. I also, of course, wanted "Team B" to get the recognition they deserved for putting in the effort required to access the bunker, taking the greater risk for the greater reward. It was at this point that I realised how deep I actually was in my research – I really was drowning in my ethnography. I oscillated wildly between thinking it was my duty as part of the crew to promote our exploits and thinking that as an ethnographer I had no right to make such decisions on behalf of my project participants. Soon after though Silent Motion told me that I needed "to stop thinking you have to be one or the other, you will always be both" (Silent Motion, November 2010) and the thought that I could possibly play this double game both excited and frightened me.

The Burlington blog post did indeed become a target of rage for members of *28 Days Later* and *Dark Places*, who claimed that we had exploited information which they "handed to us on a plate". Orangemike wrote, "you make it sound like you are pioneers. Many of us have been in and out of here for years. The only difference is the rest of us haven't crowed about it in a way that ensures increased security (and

---

<sup>31</sup> <http://www.28dayslater.co.uk/forums/showthread.php?t=66190> (accessed 11th November 2011, thread deleted as of January 2012).

<sup>32</sup> <http://www.placehacking.co.uk/2010/12/05/infiltrating-ministry-defense> (accessed 12th April 2010).

probably official interest). Well done you pretentious Prat. Place hacked? Well yes hacked, damaged, ruined.”

Oxygen Thief, the administrator for *28 Days Later* whom I had never met, banned me from the forum for life and called me on my mobile phone, telling me that if I didn't take the post down I would “fucking regret it” and that he would “sick the MOD (Ministry of Defence) Squad on us” (Oxygen Thief, November 2010). I refused and he mobilised people on the forum to attack me in the comments section of the blog posting. It became clear, eventually, that his primary motivation for the ban and personal threats had more to do with the fact that we had taken credit for our successful exploration publicly, though the explorer Speed, who was part of a different explorer group, had already discussed the site publically. My effort to find out who was enforcing this mythic “code”, painful as it was, proved fruitful, “the ego... called forth in a dramatic way” (Lyng, 1990b: 860).

Indeed, the whole Burlington episode revealed the pretensions and politics involved in the UK urban exploration scene, the testosterone-fuelled competitiveness and feelings of ownership (the preservation instinct) built around exploration locations that underlies much of the work that takes place. As I steadily received phone calls and messages of support from other explorers, it was obvious that many people in the community, at some point or another, had become the target of a mob attacking them for a “mistake” they made. The thread on *28 Days Later* turned into a heated battle site between those attacking and those defending me. Luckily for me, a number of people including Dsankt, Siologen and “Gary” came to my defence while I monitored the discussion via an alter ego and a VPN client that hid my IP address. The mob eventually lost interest over the course of a few weeks. Dsankt emailed me in the meantime, telling me “there's something

just so inherently cowardly about the lynch mob that forms whenever someone gets their hate on.” He went on to say that “reasoned logical resolution of problems doesn't even seem to occur to them” (Dsankt, December 2010). As much as the episode served to sever us from the rest of the UK scene, it also solidified us as a crew as my friends rallied to my support.

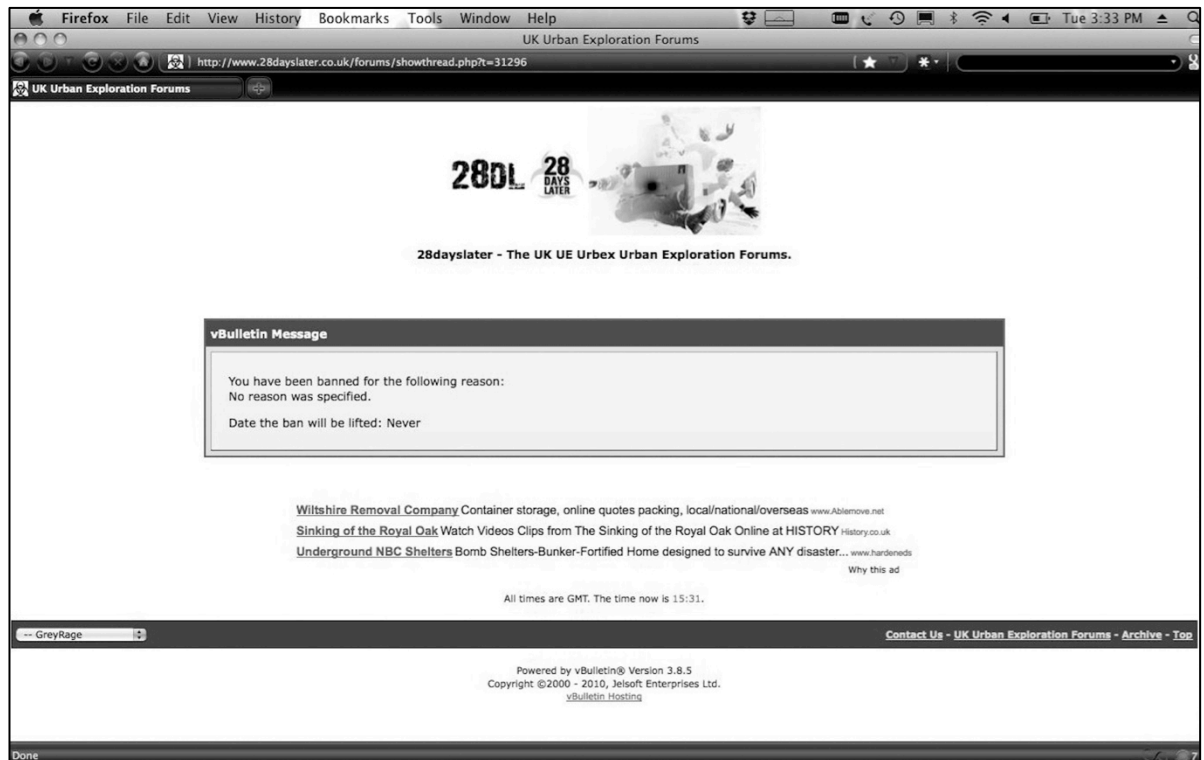

Figure 76. Banned for life from 28 Days Later, screenshot via author

While it would be easy to link the group's attitudes towards control over information sharing to the mostly male demographic and an associated competitive alpha-male complex, I think it also just as much to do with the existential philosophical and libertarian political beliefs that most explorers subscribe to. In other words, rather than seeing this episode as an example of the exclusionary nature of the practice, I argue that it is inclusionary only when a possibility for individual and group gain is threatened. Siologen later told me “shit doesn't operate like this with the Cave Clan in Australia, you guys in the UK are weirdly competitive” (Siologen, November 2010). Although I never had a chance to

explore in Australia, I don't doubt for a minute that the internal political turmoil caused went hand in hand with the deeply political nature of social life in the United Kingdom (I have since been made aware of similar situations in the United States). As Patch said later about our success at Burlington, most explorers "didn't understand it being hypocritical to tell people off for breaking into places when our shared pastime revolves around breaking rules" (Patch, October 2010). He went on to say that the urban exploration community claim

...they don't condone causing damage or committing criminal offences to gain access, and they don't do it themselves. But they also refuse to admit that it wasn't for *someone* tankcatting [forcing] their way around and no 'explorer' being willing to do it, then basically none of the classic asylums or industrial sites would have ever been done (Patch, October 2010).

While it is true that most places are opened by somebody who has come before, our night in Burlington brought renewed vigour to the group and created an even more intense bond between friends, now liberated from association with the larger 3,000 person plus UK community, a move that would inadvertently connect us to a larger swath of the global "elite" of urban exploration (defined by the quality, quantity and geographic range of their explorations). After years of shedding one set of rules (society at large) only to feel we had adopted another (the UE code of ethics), we finally started writing our own. It was the "rebirth of the rebellious subjectivity" (Lyng, 2004: 371).

In time, our now vehemently cohesive crew became increasingly adept at locating, sneaking into, and even temporarily residing in marginal spaces, cracking those which hovered on the edge between urban exploration and infiltration. While doing so, we were all aware that Snappel, Siologen, Zero (Otter) and a few other had been sneaking into the city's infrastructure. These infiltrations being undertaken by "London Team A" consisted of five primary components –

construction sites, electricity and cable tunnels, deep shelters, the city's drain and sewer network and what many of us saw as the most daunting challenge – the city's transportation network including the London Underground (Tube). As our appetite for new experiences grew, the musings of Ninjalicious became increasingly poignant where he said in an interview with Dylan Trigg in 2005 that "I wouldn't say what [urban explorers] are looking for is the beauty of decay so much as the beauty of authenticity, of which decay is a component" (Trigg, 2005). Team B was running on overdrive and ready to go to great lengths to find that authenticity and to, as Silent Motion said in chapter 1, do whatever was necessary to connect with the city.

To my surprise, the Burlington episode earned us some admiration from Team A – perhaps as much for the lifetime ban as for the success at accessing the sealed location. Months later, when myself and a few other explorers, including some from "Team A" threw a birthday party for Marc Explo on the 29<sup>th</sup> floor of King's Reach Tower,<sup>33</sup> other prominent members of Team A, mutual friends of Marc Explo, showed up. Siologen announced he was leaving the country and he suggested that we should all start exploring together, now that we had taken our first public bruising and begun carving our own path outside the restrictions of the web forums. What followed was the collapse of the two top London crews, now reformed as the London Consolidation Crew or LCC, an infiltration crew concentrated on cracking London's infrastructure.

---

<sup>33</sup> For video footage of the party see: <http://vimeo.com/17033526> (accessed 12th November 2012).



Figure 77. Marc Explo's 29<sup>th</sup> birthday in King's Reach Tower: the formation of the LCC, photo by Otter



Figure 78. Marc Explo in the GLC pipe subways, one of our first live infiltrations, London, photo by author

When I asked “Gary” during this time about our move into infiltration he said, “ruins are great and I will keep exploring them but they are kind of ‘outside’ the



city. I like doing [infrastructure] because it's inside the city" (Gary, December 2010). Like ruins, we found that "...urban networks in the contemporary city are largely hidden, opaque, invisible, disappearing underground, locked into pipes, cables, conduits, tubes, passages... Once completed, the networks became buried underground, invisible, rendered banal and relegated to an apparently marginal, subterranean urban underworld." (Kaika and Swyngedouw, 2000: 121, Graham and Thrift, 2007). Revealing them was part of finding that urban authenticity we desired, a way of connecting ourselves to the city through nightly body work. As I will show, this sometimes involved removing locks, copying keys, disabling alarms, popping pins off hinges, climbing with ropes, removing loose boards of metal slat in ventilation systems, carrying screwdrivers, hex and drain keys, scaling barbed and razor wire, climbing through air ducts and generally thinking of the city more as a puzzle that could always be taken apart piece by piece. Most often, we could put it back together as well. However, once we moved beyond ruin exploration, exploring was no longer simply a matter of climbing through an open window or avoiding a lone security patrol in a massive derelict site.

Our move from urban exploration to infiltration, framed in terms of increasingly vertical movement above and below street level, became an "'extravagant passage' through the city in an attempt to discover and remake it" (see Knabb, 1981, Sadler, 1998 quoted in Dickens 2008a: 16). Following geographer David Pinder's thoughts, Luke Dickens writes, "the Situationists [also] sought to counter the contemplative and non-interventionist power of the spectacle 'by intervening in the city and experiencing its spaces directly as actors rather than spectators'" (2005b: 149, quoted in Dickens 2008a: 16) and urban infiltration, following "Gary's" comment, increasingly felt like we were building a deep relationship with

the city. Part of this process was of course becoming more criminal minded, embracing our hacker ethos in chasing our interests wherever they led. Although I had initially intended not to write about those activities, thinking them outside the remit of my research interests in alternative and populist histories, when I returned to sociological literature from the “new” Chicago School, I was again reminded that as difficult as it might be politically and academically to defend our live infiltrations, those parts of this story were also a vital component of the ethnography. Instead of searching for other people’s histories in places, we had begun revealing histories and places no one had ever formally documented. My field notes from the time revealed my feeling that what we were doing was not taking things off in a novel direction but, in effect, bringing urban exploration back to its roots.

*I really think the core of urban exploration has always been infiltration. The practice is about going places you're not supposed to go, seeing places you're not supposed to see. Some of the earliest popular accounts of urban exploration are about sneaking into hotel pools, climbing bridges, going into city infrastructure and exploring construction sites.*

*The scene here in the UK, and Europe in general, has really been hijacked by ruin fetishists in the past five years who actually don't take many risks and have veered the practice away from it's more political roots where the need for planning, scoping and building tactical skills such as lock picking, alarm disablement and abseiling have been sidelined in favour of more artistic pursuits. This has partially to do with the current economic climate and the increasing number of abandoned places in Europe, leaving a lot of ruins to explore, but I think it's also a capitulation to the culture of fear that keeps us from doing what we really want to do. Of course, if people are happy just exploring and photographing abandoned places more power to them, but I see room for sustained, comprehensive work hacking urban architecture.*

*What the LCC, as an infiltration crew, is doing now is to pare the practice right back to it's core, cracking the most difficult boundaries for the highest rewards and, in the process, making an important political statement about the porousness of urban security, despite constant assertions to the contrary. The practice demonstrates a love and a passion for a city that is rendered increasingly mundane by neoliberal forces. We make it clear that London is still full of opportunities for*

*adventure and sublime experience for those who make the effort to find it* (Field Notes, London, February 2010).

Turning to Stephen Lyng discussing the work of Jack Katz (1988), in familiar language, we find in their analysis of criminal behaviour that “some criminal actions are experienced as almost magical events that involve distinctive ‘sensual dynamics’. These criminal pursuits often take on a transcendent appeal, offering the criminal an opportunity for a passionate, intensely authentic experience” (Lyng, 2004: 361). This language of authenticity obviously has its own complications, again connected to the earlier problematized semantics of exploration, and even early academic language of anthropologists searching for “authentic” culture. However, I think the fact that the explorers were decoding their own places, their own culture, gave us more latitude to interpret it as a quest to “authentically” connect with our city, to, as Silent Motion told me, “find something to be passionate about again” (Silent Motion January 2011).

While my actions at Burlington and beyond as an academic researcher may have become ethically questionable, following Silent Motion’s assertion that “I was both”, I had to contend that the sociological literature on criminal activity pointed directly to that “authentic experience” that Ninjalicious highlighted in 2005. We were, as Dsankt had implored, “beyond the ruin fetish”, the place where the more lascivious and exciting tales of urban exploration reside where Statler finally articulated, on a night of particular legal murkiness, that “there's no more rules to exploration, there's just what your morals fit, people who aren't comfortable with it don't need to come along” (Statler, February 2011).

**Getting high**

“I wonder why progress looks so much like destruction.”  
– John Steinbeck (1997: 138)



Figure 79. Atop Strata, Elephant & Castle, London, photo by Silent Motion

Like the famous Night Climbers of Cambridge who undertook illicit night-time climbing (what we now call buildering) in the 1930s (Whipplesnaith, 2007), we looked to the tall structures, scaffolding, rooftops and skyscrapers as well as the churches and cathedrals of Paris for unsanctioned views. Heron Tower, Strata, King's Reach Tower, Temple Court, New Court, the Canary Wharf skyscrapers and eventually The Shard, perched over the Thames on wind-swayed iron cranes and cement counter-weights became our new nocturnal playgrounds.

Soon after completing the New Court crane, I put up a post on my blog,<sup>34</sup> which at the time was full of pictures of derelict buildings and had not received much attention (aside from the Burlington fiasco). The next morning I awoke to find that Web Urbanist had run a feature on my post titled "hack this"<sup>35</sup> and I had received hundreds of hits, inspiring me to consider for the first time about the potential for urban exploration to go beyond our experiences of places and actually have broader influence over creative and critical spatial practice in cities. It also occurred to me that London Consolidation Crew had potential for gaining even more recognition now that we were building the rules of the game according to our group desires rather than the broader social community expectations.

At the height of my involvement, we were going out almost every night and my list of project participants doubled with the collapse of the teams (see Appendix A). Otter, originally from Team A and now an important member of the LCC, told me at one point that he "just fucking gave up on a normal life and became nocturnal".

---

<sup>34</sup> <http://www.placehacking.co.uk/2010/02/13/lust-for-london> (accessed 14th February 2010).

<sup>35</sup> <http://weburbanist.com/2010/04/14/hack-this-erie-abandoned-roof-tunnel-hacking-pics> (accessed 14th February 2010).



Figure 80. The author climbing the crane on New Court, City of London, photo by author

On a trip to Paris, we explored so many places, from catacombs to utility tunnels to Paris Metro to drains to cranes, staying up for almost three days straight, I collapsed on a road island in the middle of an intersection while Marc Explo was dragging open yet another sewer lid and cried “please, I have to sleep, I can’t do this anymore!” sobbing into the grass.

Some within the original “Team B” were initially reluctant to undertake these new forms of exploration. Some stopped participating. I was also reluctant, given that my initial interest in these places had stemmed from my desire to find moments of populist and “authentic” archaeological and historical encounter building on previous research (Garrett, 2009). But the more time I spent climbing skyscrapers, churches and cathedrals, learning ropes, lock picking and new skills, committed to following the ethnography, the more our conversations convinced me of the similarities and overlaps between these seemingly disparate interstitial spaces. In

one instance, while climbing the scaffolding on the St-Sulpice Chapel in Paris which was under renovation, I asked Marc Explo why he felt drawn to these building and renovation sites, pointing out that this was just somebody else's workspace the majority of the week. He responded,

Brad, a construction site is like a ruin because it's in a constant state of transition and part of the enjoyment of the experience comes from being witness to that in-between moment. It's all about getting a glimpse of places normally not seen by the majority of the city's inhabitants (Marc Explo, September 2010).



Figure 81. Infiltrating the Paris Metro system with Marc Explo, Paris, photo by author

It was true that these glimpses were impossibly intoxicating, far above the city's skyline, on top of derelict tower blocks and on cranes where a slight wind caused the jib to shake seductively hundreds of meters above the city; where there was a constantly light mist as you floated in the clouds, causing camera autofocus problems. They were certainly sights most people would never see, there was no arguing with that. Ironically, as Otter told me in this anecdote, these spaces, where one is clearly not supposed to be, are often where one has the most freedom,



Figure 82. Above Paris, St-Sulpice Cathedral, Paris, photo by author

We were all climbing on a crane on a building and Alias was down on the pavement taking photos of us with a telephoto lens. We saw the cops pull up and ask him why he was photographing the crane. We laughed but it did actually prove to me that we are safer up here than in the street (Otter, September 2011).

As a crane operator points out in the 2010 documentary *Solitary Life of Cranes* (Weber, 2009), it's incredible really that so few people ever look up in the city, aside from children. From the perspective of the crane, people on the street become urban flow and rhythm (Lefebvre, 2004) and the sounds of the city, often so intrusive and abrasive, become a quiet music in the background. As Marc commented when we were sitting on top of the Shard, which was at that point 76 stories high, "at this height the train lines going into London Bridge begin to resemble the Thames, it's all flow" (Marc Explo, January 2011).

Silent Motion, sitting with me on the edge of the King's Reach Tower, watching the new Crossrail construction at Blackfriars, told me, "I keep coming back because I



feel so alive up here. It's more real than real life." Part of the allure of being this high is clearly to bond – there is a particular type of deep bonding that takes place when you trust each other with your lives when climbing buildings but we also, more personally, fed on the adrenaline rush of living dangerously. On the rooftop of Temple Court when we heard the laughter of pub-goers returning home at 3am, Tigger told me, "if they only knew how good they could feel climbing this building they have probably never noticed before, they might never go to the pub again" (Tigger, February 2009).

These shared discoveries and feelings of existential superiority bonded the crew in an emotive embrace, tendrils of affect conjured by collective fear and excitement where "...emotions can be conceptualized as the felt and sensed reactions that arise in the midst of the (inter)corporeal exchange between self and world" (Hubbard, 2005: 123). These types of experiences were new to me, being hard to locate in many modern city spaces which Guy Debord argued "eliminate geographical distance only to produce a new internal separation" (Debord, 2006b: 94). Although we were more "in" the city than ever before, being literally inside its most prominent and costly construction projects, we could sit quietly and talk together, paradoxically more capable of having an intimate conversation, than on the streets. Gary later said, "it doesn't matter if you're not doing anything up here, even boring stuff is fun sitting in a crane cab" ("Gary", February 2011). I even wrote some of this thesis in that same crane cab on a construction site above the Aldgate East Tube station, twisting my everyday life into an entirely new formation. The trade off, however, came at a high price. Once we realised what we could get away with, the adrenaline addiction became completely debilitating to everyday life and I felt myself becoming increasingly distanced from all of my

friends who did not explore. I was the worst dinner party guest imaginable, opening conversation with lines like “so yesterday we were in the sewer...” Yet it was the first time I ever felt that life was as it should be: everyday was more exciting than the last. Increasingly I didn’t care about social expectation outside of our primary group and embraced my privileged masculinity, dedicating almost all my time to learning infiltration techniques, drinking, taking photos, exploring and writing our stories. The lifestyle satisfied my compulsive nature and brought out a side of me that I didn’t know existed, a side that was, as Marc Explo said was “ready for Action!”

One night while driving around Paris exploring Metro, Patch said to me, “hey Brad, in terms of your demographics section, have you ever considered how many of us are fucked up? I mean, you’re really OCD and I think there are a really high percentage of people with Asperger’s exploring – you know, I think is satisfies that weird compulsion to collect things, make lists, spreadsheets and maps, organise gear and understand the technicalities of photography. Just a thought...” (Patch, December 2011). He was completely right of course and it made we wonder if the gender imbalance in the community had as much to do with our collective social awkwardness and collector compulsions as it did with “masculine” attitudes. Marc Explo later told me in response “I started exploring because I thought it would get me girls, you know they would be impressed with my accomplishment and I could take them on top of cathedrals to have wine or whatever. But that didn’t work so I just carried on exploring” (Marc Explo, December 2011).



Figure 83. Marc Explo climbing the Shard, London Bridge, photo by author

Despite the ways in which we were becoming increasingly socially marginalised, even within the wider UK explorer community, the work the crew was doing was of critical importance to discussions about the politics of space. We were melding Debord's "internal separation", though embodied investigation of informal spaces, liminal zones, and high profile construction projects. The process was splicing the zones of in-between into the fabric of the rest of the city by dulling the boundaries of can and can't, seen and unseen, imagined and experienced, done and not done everytime we posted a photo online and people realised we had cracked another site together. Those feats never could have been accomplished alone.

Despite the ways in which urban explorations may be seen as transgressive from the outside in, they may also, in this sense, be seen as a strategy to heal human connections through shared experiences of peaked emotions (Cahill and McGaugh, 1998) that build stronger bonds of community through collaborative risk-taking, what I came to call the "edgework" we undertook together (following Lyng, 1990a, Lyng, 1990b). Here, again, urban exploration's lineage stretches back into those Surrealist experiments in Paris where David Pinder writes they sought to "[open] up the 'marvellous' that they believed was buried within the everyday" just as the situationists valorised "sites that were out of time with the city as spectacle..." containing "hidden meanings and associations in the city" (Pinder, 2000: 379).

The desire to explore for the sake of exploring, to take risks for the sake of the experience with little thought to the "outcome" is something that runs deep in us when we are children. Urban explorers are, in one sense, rediscovering and forging these feelings of unbridled play, staying up all night, uselessly wandering, plotting, having substantial conversations during spontaneous encounters, all of which lead

to the creation of very thick bonds between fellow explorers where “play represents a way to de-emphasize the importance of work and consumption and their pervasive monetary components” (McRae, 2008: i). In places beyond the reach of those flows; “the city is rendered a site of play and pleasure, surprise and critical possibility” (Dickens, 2008a: 20). Again, as Lyng (1990a: 870) notes,



Figure 84. On the roof of Temple Court, City of London, photo by author

Research on play (Huizinga, 1950, Caillois, 1961, Wilson, 1981) suggests that this realm of human action often possesses characteristics that directly oppose the experience of people under conditions of alienation and reification. Play is characteristically spontaneous, impulsive, creative, and intrinsically rewarding and, for many people, gives rise to the “flow” experience (see Csikszentmihalyi, 1981).

Although I will unpack this in more detail in the following chapter, the increasing risk that the crew undertook to satisfy an ever-growing tolerance for risk would be familiar to those who had freedom to play and imagine as children – the realisation of dreams and fantasies eventually taking on a scale that may have at one time seemed unreasonable or incalculable. After months of constant play and discovery, feeling that we could get away with almost anything, my field notes began to look

rabid, loosing all sense of descriptive narrative and gaining an unmistakable present-tense “authenticity”.



Figure 85. The author and Hydra dancing on the roof of the Gillette factory, London, photo by Silent Motion

*Desire was everywhere when we stepped off the plane at Charles de Gaulle. We nipped and yelped, scurrying into the city wearing rags and muddied bags, dragging tripods down the walls of Métro tunnels like Freddy Krueger. The thirst, after weeks of depraved scholarship, endless perverted workdays and inert meetings over coffee, had concretised into the force of a tsunami. The wave broke at times around tall objects, splitting and climbing for a moment before splashing down again in a liquid slump of ecstasy. At other junctions, it snaked into infrastructural gaps too small for bodies. We followed the water to find the glitches in the system, trying out various keys and tools for which the original intended purpose was never understood, lost artefacts from another time, rediscovered by our nomadic band of forgotten disciples. We bled and drank, crawling into our sleeping bags when we could smell the bread baking, the delicious olfactory beacon warning us the City of Light had switched on for the day.*

*Life was “lived on the level of surging affects, impacts suffered or barely avoided. It takes everything we have. But it also spawns a series of little somethings dreamed up in the course of things” (Stewart, 2007: 9). Exploited, those affects, glitches, errors in lines of code, paired to the desires to find them, become the preeminent domain of the urban explorer, the skateboarder, the street artist and all children while they are still conscious, before society batters them into submission, huddled*

*in the corner of an overcrowded classroom where they are forced to recite the national anthem repeatedly.*

*Desire wasn't purchased, nor did we try to sell it. At the same time, it was a profitable endeavour, an investment in the communication of the incommunicable, a necessary departure from direct economic production.*

*Urbanity is codified by a set of rules which creates spirals of economic 'prosperity', where relentless velocity must be maintained to preserve the perpetual accumulation of wealth, resources and labour. The result is a system which reproduces itself in ceaseless iterations like a demonic fractal art project, even (or even especially) when those accumulations are superfluous or unnecessary, until it pops.*

*"At its most extreme, capitalism encourages a kind of generalised schizophrenia, a shatteringly intense fracturing of subjectivity. On the other hand, to survive it has to contain these effects through oppressive fictions like the nuclear family and psychiatry, which attempt to 'reterritorialise' desire: to put it safely back inside the home and to keep it there" (Shatz, 2010 discussing Deleuze and Guattari). Night after night in Paris on this trip, we took the secret desires from home and mind into streets and practice. While the Marxists sit in Starbucks with their coffees crying for the overthrow of the system and the anarchists fight each other in squats, condemning comrades as sexists and fascists, we are creating desire. We are coercive machines that produce breaks and mobilise flows, nude in sewers, hanging from cranes, in love with the endless accelerations of material layering that keep cracking open underneath the weight of 7 billion human bodies.*

*The result? An endless stacked stratigraphy of created miscommunications, abortions and aberrations, interminable confusion about what could and should have been, sparkling smiles as the successful accumulation is directed into personal coffers, suicide from bridges where it does not. What sprawls all around us everyday, whether we are in London, Milan, Paris or Los Angeles is a capitalist monstrosity that regrows heads as you slice them off. Our only advantage against this unkillable and utterly beautiful beast is its immensity, for it is this very horrific attribute that allows us to run underneath unnoticed while it spews poison in the Siene.*

*Urban explorers are the result of inevitable urbanic schizophrenia. While the dragon spews its poison, wagged by its own tail, we urinate on its leg, chuckling as our playfulness conjoins deterritorialised resources and temporarily appropriates the surplus from their reterritorialised conjunctions in nice little packages of pixels to print and mount illegally in a derelict barge on the Thames we've occupied. "To each moment, we cling with all our heart, knowing it is unique and irreplaceable – and yet we wouldn't lift a finger to prevent it from being annihilated" (Sartre and Baldick, 2000: 59). We will play, in this form and others, in*

*imaginative permutations of superhumanity that don't yet exist, again and again, until we are dead* (Field Notes, Paris, January 2011).

I include this excerpt not to make any specific point, not in the least in a scholastic sense, but to relay the utter euphoria I was experiencing at the pinnacle of our spatial liberation. I truly felt, as Marc Explo asserted, like some sort of monstrous postmodern superhero. I knew the others were feeling similarly and we all began to “crowd the edge” (Lyng, 1990b: 860) grabbing at the desire leaking all over the place.



Figure 86. Patch in the Barbican utility tunnels, London, photo by author





Figure 87. The author at play, *St Josefsheim* Monastery, Germany, photo by author

**Doing edgework**

“We entered, by this hidden path to fare  
To the bright world, from out of the place of doom,  
Nor cared to rest upon the arduous stair,  
He first, then I, till saw I in the gloom,  
Through a round opening, as though through prison bars,  
Heaven’s lovely harvest fields, and, from our tomb,  
We issued forth again to see the stars.”

– Dante Alighieri (1920: 393)

After balancing on a girder in any icy wet wind atop Heron Tower in the City of London, Silent Motion wrote on his blog that, “sometimes I just desire the edge. It’s not about adrenaline or ego or any of that bullshit; it just happens, as if drawn by the reins held by some deeper level of consciousness”.<sup>36</sup> In the moment this photo was taken, it seemed to me that Silent Motion was issuing a distinct challenge to those who would seek to disembody, sanitise and commodify our personal experiences, those who would turn the city into a mausoleum of spectacles of sights to be seen rather than places to be touched; he had hacked reality and found his edge. All of us, it seemed to me, were dangerously close to letting desire reign unchecked and getting caught in a spectacular way – we were beginning to feel invulnerable and the edge was getting closer.

Edgework was a term first used by gonzo journalist Hunter S. Thompson in his book *Fear and Loathing in Las Vegas* to describe the necessity some people find in pushing boundaries for fulfilment. The idea is to work as close to the “edge” as one can without getting cut (or at least not too deeply). For Thompson, this meant putting himself in perilous situations such as doing ethnographic research with the notorious Hell’s Angels biker gang, ingesting hallucinogenics to the point of near overdose and taking drugs of unknown origin in unexpected combinations.

---

<sup>36</sup> [www.nocturn.es](http://www.nocturn.es) (accessed 1st December 2010, site down as of February 2012).



Figure 88. Doing our edgework, Silent Motion on Heron Tower, City of London, photo by Silent Motion

When Thompson tried to describe “the edge” of edgework in his 2003 autobiography, he wrote,

The Edge... There is no honest way to explain it because the only people who really know where it is are the ones who have gone over. The others- the living- are those who pushed their luck as far as they felt they could handle it, and then pulled back, or slowed down, or did whatever they had to when it came time to choose between Now and Later.

But the edge is still Out there. Or maybe it's In (Thompson, 2003: 530).

The sociologist Steven Lyng appropriated the term edgework in the 1990s as a blanket term for anyone who “actively seek[s] experiences that involve a high potential for personal injury or death” (Lyng, 1990a: 851-852, also see Olstead, 2011, Fletcher, 2008). Lyng goes on to explain edgework as a negotiation between “life and death, consciousness and unconsciousness, and sanity and insanity” (Lyng, 1990a: 857) and describes how and why his project participants approached the edge,

The mundane everyday world provides the boundaries and edges that are approached. And it is the very approach to the edge that provides a heightened state of excitement and adrenaline rush. The thrill is in being able to come as close as possible to the edge without detection... (Lyng, 1990b: 53)

Many urban explorers not only feel the need to test those limits, but to actually change the collectively perceived limits of possibility, to move the edge. Edges are found in drain systems, where the obvious risk comes from flooding, drowning and (less likely) cave-ins to abandoned buildings which have both short term (collapse) and long term (respiratory problems, cancer) perilous impacts on our bodies to high places, where falling is always a possibility.<sup>37</sup> In these locations, unregulated by health and safety, urban explorers are free to do edgework,

---

<sup>37</sup> In 2009, Downfallen, a prominent London urban explorer and BASE jumper, fell to his death while BASE jumping in Switzerland (see <http://www.skyscrapernews.com/news.php?ref=2414>). The next year a 13-year old Swedish boy fell into an underground canal in Stockholm (see <http://www.oursisthefury.com/2010/the-fall-of-urban-exploration/>). Then in 2010 the explorer Solomon fell to his death from a hotel balcony in Thailand (<http://www.guardian.co.uk/world/2010/aug/26/urban-explorer-hotel-death-fall>) (all accessed 8th November 2010).

(re)locating boundaries by hanging from cranes, balancing on edges of long drops, precariously tiptoeing over weak floors and scrambling under collapsing structures.<sup>38</sup> Neb, when I asked him why he insisted on swinging from every high thing we climbed (including jibs of cranes) with ropes and a harness he carried, he told me, “well, I want the rush and I figure if I fall at least I’ll be dead and not disabled” (MC Nebula, July 2011).



Figure 89. "Gary" doing his edgework, abseiling 30 meters into the pre-metro ventilation shaft, Antwerp, photo by author

William Gurstelle (2009: np) writes that “done artfully and wisely, living dangerously engages our intellect, advances society and even makes us happier.” While creating strong bonds of trust between exploration partners, edgework also reaffirms individual subjectivity and creative potential; “to think of the subject as an autonomous self... authorizes the fear that if the boundaries are breached at all, there will be nothing to stop the self’s complete dissolution... when the human is seen as part of a distributed system, the full expression of human capacity can be

<sup>38</sup> <http://www.nopromiseofsafety.com> (accessed 9th November 2010).

seen precisely to *depend on the splice* rather than being imperiled by it" (Hayles, 1999: 290, italics mine). Where we spliced self and place, where we invoked the meld uninvited, we created new vibrant urbanisms the likes of which we may never have known existed otherwise.

*It was a crisp night outside London Bridge station. It was still but our breath curled in the 2am air. Marc Explo and I were standing on a temporary wooden walkway looking through a viewing window into the ground level construction yard of the largest skyscraper in Europe. "Gary" walked up behind us and, with a pat on our shoulders, also peered through. "One security guard looking after the Shard huh?" he said and we chuckled. We waiting for the guard to finish his current round and go into his hut. It took a few minutes of lingering before the walkway was clear of people – we grabbed on to the scaffolding pipes and swung off the bridge. Hanging on the freezing pipes, we pulled ourselves on top of the walkway and laid down out of view, waiting for a reaction in case anyone had seen or heard us. It didn't seem so.*

*Staying low, we then descended the other side of the scaffolding, right behind the security hut where we could see the guard watching TV, not the cameras. Quickly, we scampered across the yard and found the central stair case, again pausing to see if there was any reaction from the yard, phones ringing or doors opening. It was silent.*

*First we took the stairs two at a time. All three of us were in pretty good shape and could do 25 or 30 floors like that. But by the 31<sup>st</sup> floor, I was sweating heavily. Knowing that the sweat would sting when we emerged onto the roof, I tried to pace myself and breathe. By floor 50, my calves burned horribly and I was having to stop every once and a while to let them pulse a bit and untighten. When at floor 70 the cement stairs turned into metal ones, indicated we were near the top, I was ecstatic. I final burst of enthusiasm took us from metal stairs to wooden ladders. We threw open on last hatch and found ourselves on top of the Shard at 76 stories.*

*As I climbed up on the counterweight of the crane, my breath caught. It was a combination of the icy wind and the sheer scale of the endeavour that shocked me. Slowly, I pulled myself to the end of the counter weight and peered over the edge down to the Thames. We were so high, I couldn't even see anything moving at street level. No buses, no cars, just rows of lights, train lines that looked like converging river systems, a giant circuit board.*

*We found the cab of the crane open and sat down inside. "Gary" pointed to a green button on the control panel and said "watch this, I'm going to build the Shard!" and pretended to press the button. We only lasted about half an hour on top before our muscles were seizing up and we*

*were actually yearning for the stair climb down. Which is always much easier than coming up.*

*Later, standing next to the Thames and staring up the Shard at the little red light blinking on top of the crane, it seemed unimaginable that I had my hands on that light just hours earlier. Ever after, whenever I see that Shard from anywhere in the city, I can't help but smile (Field Notes, London, February 2011)*



Figure 90. "Gary" "builds" the Shard, London, photo by author

Urban exploration, like street art (Dickens, 2008b), skateboarding (Borden, 2001) and parkour (Mould, 2009, Saville, 2008), is a practice which reappropriates urban space for an unintended or unexpected use that may result in bodily harm. One of the common reactions to people choosing to take unnecessary risks is, of course, suspicion that these people are acting “transgressively” (Cresswell, 1996). But as Christopher Stanley has written, “these subcultural events [could] assume the status of resistant practices not in terms of ideology but rather in terms of alternative narratives of dissensus representing possible moments of community” (Stanley, 1995: 91).



Figure 91. The author on top of the Shard, London, photo by author



Those moments of both individual accomplishment and collective identification come from the notion that explorers are doing “...work carried out on ourselves by ourselves as free beings” (Foucault and Rabinow, 1984: 47). Skydivers have espoused similar notions during ethnographic interviews conducted by Lyng. One jumper said,

While we're riding in the airplane on the way to jump altitude, I always feel scared and a little amazed that I'm fixing to do this bizarre thing-jump out of an airplane! But as soon as I exit the plane, it's like stepping into another dimension. Suddenly everything seems very real and very correct. Free-fall is much more real than everyday existence (Lyng, 1990a: 861).

The release of adrenaline clearly becomes addictive, causing participants to spend an increasing amount of time and energy chasing the release. In Belgium, we actually entered a live blast furnace in the middle of the day and snuck around the grounds, running up stairwells when workers had their backs turned. When I asked Statler whether he thought he was addicted to the adrenaline rush we got from those sorts of infiltrations, he told me “well everything else was boring anyway, so I guess I'd rather be addicted” (Statler, August 2010).

As Lyng rightly points out, “risk taking [is] *necessary* for the well-being of some people” (1990a: 852, emphasis in original) as individuals work to “develop capacities for competent control over environmental objects” (see Klausner, 1968: 156) inspiring edgeworkers to “sometimes speak of a feeling of ‘oneness’ with the object or environment while undertaking these risks” (Lyng, 1990a: 861). Silent Motion told me that the places he felt he had the deepest relationship with were where risks had been taken, social codes broken, and new social templates drawn up from desire and the recognition and transcendence of fear. In those places, urban explorers have bonded not only with Lyng’s “object and environment” but also with friends who shared those risks. Similar to what Saville (2008: 891) found

in his work on parkour, participants are “trying, experimenting, and gradually learning to be in places differently” (Saville, 2008: 891) and many find that process liberating. It is a rare moment when “‘knowings’ and skills of the body organize action in the absence of the social mind” (Lyng, 2004: 360), an embodiment of individual subjectivity that gives agency to the actor by allowing them to submit to, or indeed create, a moment outside of normative everyday space (see chapter 5) and revisit it on terms of one’s own choosing.

If we follow Sanders’ claim that where “the body and its pleasures [are] a locus of political meaning, a site of both political repression and liberation and we can see that criminal pleasures also incorporate forms of political resistance and escape” (1995: 314), the transition from urban exploration to infiltration to edgework and place hacking is a move deeper into the libertarian notions of freedom that many explorers embrace. Clearly, where “freedom is what you do with what’s been done to you” (Sartre quoted in Wright, 2008: 98), the desire to explore subterranean and aerial urban space could be seen as a reaction to a growing existential angst in urban inhabitants built on a feeling of frustration where “...the desire for alternative options starts with disappointment and anxiety” (Rapp, 2010: 38). This frustration is on public display in a manifesto for draining by the Cave Clan member and avowed anarchist Predator where he says, “we enjoy thumbing our noses at petty bureaucrats and puerile legislators, and their half-baked attempts to stop us going to the places where we go... places they built with our tax money” (Predator, ND: 2).<sup>39</sup> Predator demanded public access to public works and drains were his favourite targets. It is to draining we turn next.

---

<sup>39</sup> <http://www.infiltration.org/observations-approach.html> (accessed 12th November 2010).

**The sub in subterranean – sneaking under the city**

“Public access to public works!”

– Predator, Sydney Cave Clan (ND: np)

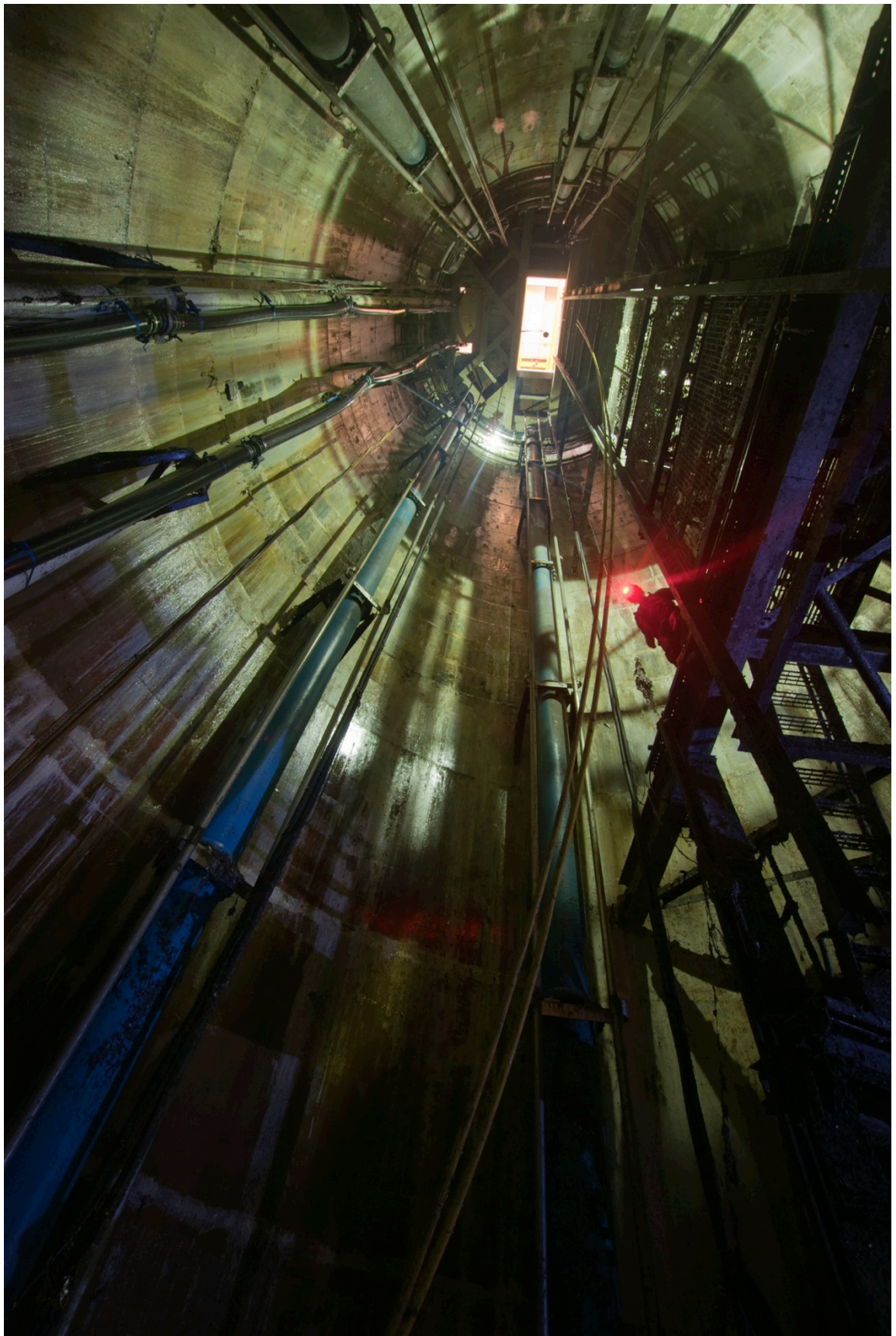

Figure 92. The author in the Colossus of the South (COTS) drain, Brighton, photo by author

As Graham (2000: 271) has written,

The expanding subterranean metropolitan world consumes a growing portion of urban capital to be engineered and sunk deep into the earth. It links city dwellers into giant lattices and webs of flows which curiously are rarely studied and usually taken for granted.

Through these new infiltrations, the group became gatekeepers to an intimate spatial knowledge about the urban environment most of the city's inhabitants ignored, a role both empowering and exciting. Again, Ninjalicious stated it beautifully when he wrote that "rather than passively consuming entertainment, urban explorers actually strive to create authentic experiences, by making discoveries that allow them to participate in the secret workings of cities and structures" (Ninjalicious, 2005: 3). These secret workings were evident not just from the dazzling heights above the city where we did our edgework but from below street level where pumping bass from nightclubs, the sounds of rolling tyres over manhole lids and high heel clicks-clacks drifted down to us as we walked single file through urban cable networks and drain systems in stunned rapture, the waste of our fellow inhabitants flowing over our fishing waders. We excitedly revealed the extent to which the city was interconnected, where "buildings extend into the ground, connecting directly with a city's arterial systems of transportation, communication and resource distribution" (McRae, 2008: 17). But these networks connect people as well as places.

In the book *Divided Cities*, a sewage worker in Cyprus tells the authors "all the sewage from both sides of the city is treated...the city is divided above ground but unified below" (Calame and Charlesworth, 2009: 121). While London and Paris, our two primary locations for exploration, are not divided quite in the way Cyprus is, it was the unveiled interconnectivity we didn't even know existed that excited

many of the explorers. At times, we could quiet literally find the boundary point between, for instance, a government bunker and the London Underground, putting our ears to the brick wall separating the two and listening to Northern Line trains fly by. Empowerment came in knowing that in three hours with a hammer and chisel, we could reconnect two subterranean networks, rework space as we chose.

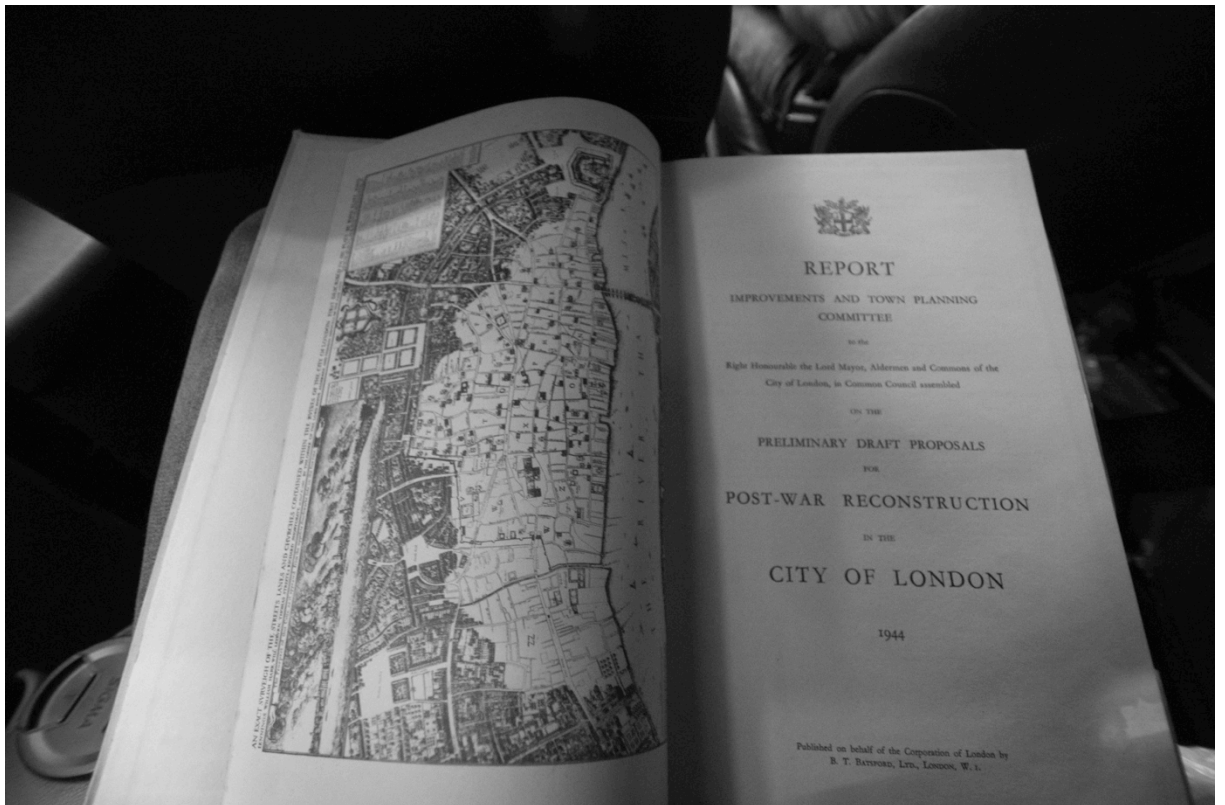

Figure 93. Neglected public information, the post-war infrastructural layout of the City of London, photo by author

When Winch, Otter and myself went to visit Marc, Dsankt, Iris, Olivier and Kat in Paris in January 2011, we entered a sewer lid in a side alley and walked for some time underneath the city before finding a side channel in which there was a ladder. Climbing the ladder, we found ourselves on top of a metal mesh walkway going over a highway. Following it further, I gasped when I realised we were walking over the Seine in some sort of maintenance area *inside* the bridge, totally invisible and inaccessible from the road on top. Halfway across, we dropped down onto one of the bridge supports. Dsankt and I then climbed out onto the bridge infrastructure over the swirling Seine and sat on a beam for a photo. Continuing

along the bridge, we found that it, strangely, placed us inside a power station, which we also explored. At the end of the night, we had “cubed” the location and ended up moving miles across Paris having traversed sewers, utility tunnels, bridges and a power station, the connections to which would have never been obvious from the view of “everyday space”. Of course, importantly, once we had taken the route, learned the connections, and knew that it existed, it became a viable way to move across the city, changing our perception of traversable space indelibly. It was also, ironically, probably a safer route than crossing the bridge over the Seine by foot from a purely physical standpoint.

Just as ruins offer up enticing juxtapositions, “conventional accounts of the uncanny suggest that, in passing from the world above ground into that below, we are entering a new intensity of zones between the rational and irrational, nature and culture, male and female, the visible and invisible” (Gandy, 1999: 34). When entering the sewer networks, this became clear as we passed through a literal threshold (the sewer lid in the street) into a world where the only social expectations to be found were the ones we chose to bring with us. In Paris, the networks urban explorers have discovered, negotiated and built are so extensive that we can traverse the city underground at times more efficiently than aboveground. The underground culture of “cataphiles” is so enticing many Parisians spend more time living under the city by candlelight than in the “City of Lights” above (Garrett, 2011b, Shea, 2011).

In a sense, the explorations of the crew became less about the places themselves and more about the freedom to choose to spend time as they saw fit, choosing how to interact with the environment and experiencing the “pleasure and excitement of

being drawn out of one's secure routine to encounter the novel, the strange, the surprising" (Sandercock, 2003: 403). We stored that information in our brains and hard drives, making us more active and participatory citizens in the way we contently acted, reacted to and caused reaction in the city. However, I felt these explorations were becoming more about boundaries than sites, more about the hack than the place.



Figure 94. Breaching the threshold, London, photo by author

Here we make an important connection again to the work of Tim Cresswell who argues that "although 'out of place' is logically secondary to 'in place', it may come first existentially. That is to say, we may have to experience geographical transgression before we realize that a boundary even existed" (Cresswell, 1996: 22). When I asked Statler about our transformation into an infiltration crew, he responded, "when you become obsessed with pushing these boundaries, you move from urban exploration to infiltration" (Statler, October 2010) and once you cross

that boundary, it's very hard to go back, each success marking a new boundary we could then cross with relative immunity.

Although we might be tempted to make connections to transgressive mobilities like those undertaken by the American Beats (Cresswell, 1993), urban exploration, as well as being transgressively empowering, also creates a group dynamic of deep investment in the places we hacked where "various objects constitute the basis of an 'imagined presence' carrying that imagined presence across the members of a local community." (Urry, 2005: 80). Urban explorers know and love cities inside *and* out because in many cases they learn cities inside *then* out. Rather than directly resisting through transgression, urban explorers are investing through subversion, even as those moments of investment are indebted to the modern legacy of transgression (graffiti, punk, hacker and beat culture, etc.), by their (at times) complete disregard for what is socially expected or acceptable. But the libertarian philosophy behind much of the motivation is not to be mistaken for anarchism. Again, Marc Explo makes the point,

I believe we are an apolitical movement. I would not like to associate, for instance, with a group who protests against the waste of empty space in prime locations. I don't think we are against the system, we're just pointing out its limits. And as soon as the authorities realise we do, the boundaries evolve; that's the game (Marc Explo, September 2011).

Of course, these games do involve those outside the community and explorers are also interested, though this remains largely unspoken, in mental shifts they can inspire not only in themselves but also in the urban inhabitants who witness our spatial hijacks.





Figure 95. Light painting a bunker in Dover, photo by Vanishing Days and author

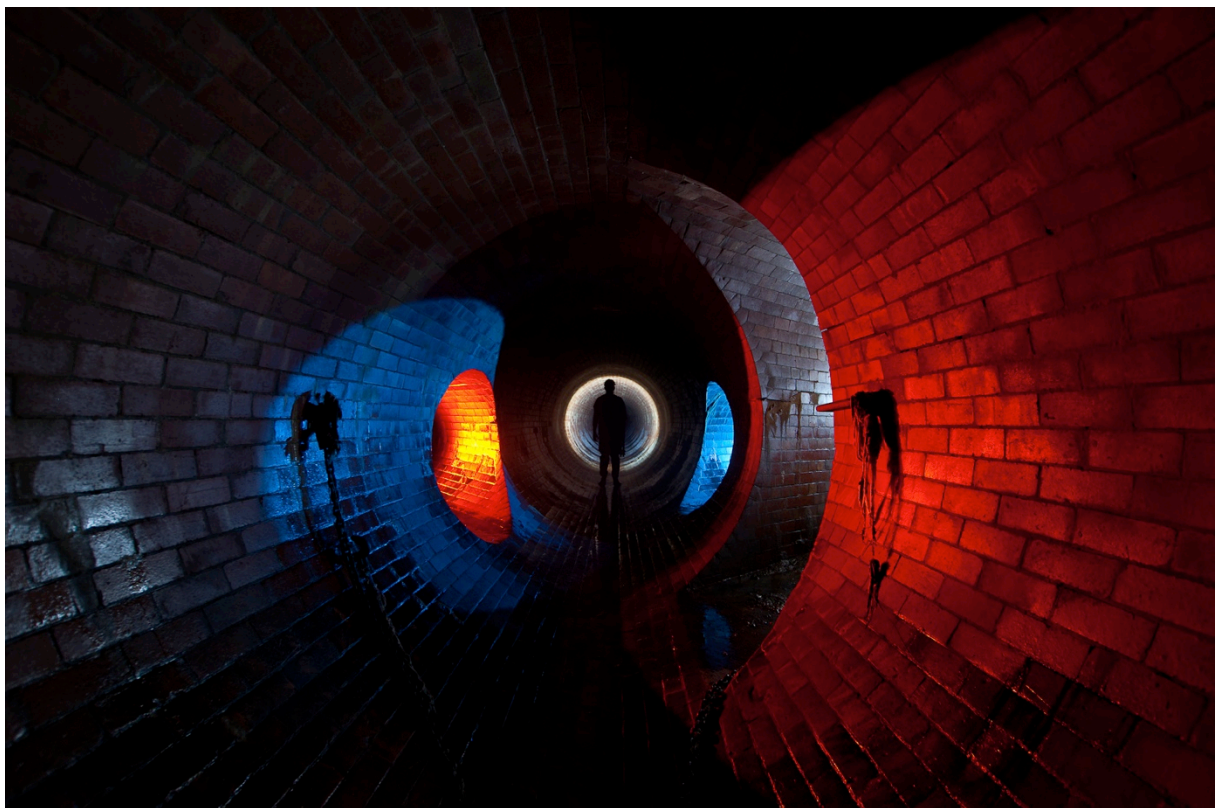

Figure 96. Playful lighting, Rubix, River Effra, South London, photo by Silent Motion, Statler and Author

As Luke Dickens writes about street artists, “there is a good deal of evidence to suggest that various publics seem to view some of these alternative inscriptions as a beneficial and desirable part of living in the “creative city” (Dickens, 2008a: 26). Physical display of action, rather than a virtual representation of potential action, was often seen as valuable in “awakening” the people around us, again highlighting the importance of embodied knowledge and grounded potential. Each exploration has the potential to open a new urban ludic space (Stevens, 2007) where we can, for instance, playfully decorate places with light during long exposures.

As John Hollingshead noted in 1862, “there is a fatal fascination about sewers, and whenever an entrance is opened, a crowd is sure to gather” (Hollingshead, 2009 [1862]: 60). In these instances, in contrast to covert exploration of ruins, emergence from infrastructure into public space encouraged bystanders to question the urban environment around them, much to the explorer’s delight. An excerpt from my field diary illustrates the point:

*Tonight Statler, “Gary” and I infiltrated some utility tunnels under Bloomsbury dressed as construction workers. We had entered a lid in the middle of the street at around 9pm and when we returned to the entrance at close to midnight (also the only exit) we could hear a crowd of people outside. We all decided just to get out quickly, not knowing what was happening above. As we emerged, people started screaming and laughing and we realized the nearby theatre had just gotten out and everyone around us was dressed smart and holding drinks. Some woman pointed at us and screamed “oh my god, it’s the Ghostbusters!” We all laughed nervously, closed and locked the lid quickly and returned to the car. Driving away as we pulled off our “costumes”, we all laughed about the absurdity of the situation, hugging each other with tears in our eyes. Gary, barely able to speak through his laughter said “those people are going to be trying to figure out what the fuck just happened for weeks!” And he’s right, if those people spend more than a moment thinking about what just happened, it will be pretty clear we weren’t legit at all (Field Notes, London, July 2010).*

In these situations explorers go beyond asserting “I did this” (as through photography) by intentionally implying “you could also choose to do this” and “the political implications of this intentionality lie not just in the transgressive action itself, but in the resistance of the status of passive citizens” (Rapp, 2010:45). The transition into infiltration from ruin exploration seems, in hindsight, an organic progression. Those early ruin explorations revealed cracks in the façade of the urban spectacle. Urban exploration, in this light, is nothing less than a rejection of our enforced pact with social norms in the process of questing for sites of urban tenderness under the hard and fluid city, flippantly exploiting those capital investments to find places where alternative channels of investment in places resided in all their duplicities, authentic and strange forms.

In these spatial reinterpretations, bonds, desires and the need to find deeper communal meaning in life take precedence over the ability to create profit or to produce something. It was often commented by the crew that we were having a better time than all those poor saps seeing a show or getting wasted in the pub or sitting at home watching television. While those comments are of course somewhat arrogant (include Siologen’s classification of “normal” people as “the dumb fucking retards up top”, see video 9 – *IDM 2011*, 1:16), I think that militancy, again, comes from the explorer’s frustration with constantly negotiating an ever constricting spatio-political landscape and desire to be left to interact with the city in whatever way they see fit. The excitement of those engagements with the city causes an overwhelming desire to share them that often translates into disdain for whoever isn’t receptive to the explorer’s desire to hack places and tell the tale.

Urban exploration is a way to create room for disjunction and difference through what Justin Spinney has referred to as “tactical subversion” (Spinney, 2010) by

weaving an alternative spectacle (Dickens, 2008a) that explorers expect may please others. Their spatio-subversions allow the explorer to observe not just what is hidden on the streets but to experience the hidden verticality of the city from cranes towering over under-construction skyscrapers and from within hidden rivers and drain networks of contemporary metropoli. In her book *New York Underground*, urban explorer Julia Solis writes that “the real adventure is far below, down the elevator shaft, where you can feel and smell what New York is really made of and where the very fabric of the city vibrates with life” (Solis, 2007: 3). Again, that tone of “authentic” experience manifest, regardless of whether explorers are in derelict, under construction or infrastructural space, usually framed, perhaps unfairly, in contrast to “everyday life”.

By 2010, we had had begun to seriously start mapping out and exploring the famous sewer system built in the 1850s by Joseph Bazalgette (Dobraszcyk, 2005) and the London Underground (Tube), encouraged by the groundbreaking work of “Team A” explorers John Doe, Zero, Snappel, Dsankt and Siologen (Manaugh, 2009, Zero, 2009), the first explorers to crack the sewer and drain network, now often in collaboration with them. These vertical explorations became new points of contestation to the philosophical and political underpinnings and boundaries of the practice as the exposure of such interstitial spaces added the “poignancy of the vertical axis to our understanding of the cultural appropriation of urban technologies, since the subterranean environment is not only a technological construct, but also ‘a mental landscape, a social terrain, and an ideological map’” (Williams, 1990: 21).



Figure 97. Yaz and the author at Lucky Charms, River Effra, South London, photo by Otter, Yaz and author



Figure 98. Winch in the river Tyburn, West London, photo by Winch and author

The map of London looked quite different when taking into account the Fleet, Westbourne, Effra and Tyburn sewers, crisscrossed by subterranean storm relief systems, cable and utility tunnels, the Tube and deep shelters. Essentially, London, in any one place, might be composed of five or more “layers” of space, with daily life for most inhabitants only taking place in one where explorers move readily between them all.

In short, where “the ruin is invoked in a critique of the spatial organization of the modern world and of its single-minded commitment to a progress that throws too many individuals and spaces into the trash” (Hell and Schönle, 2010: 8), exploration of derelict places in the city, and the political implication of not only what space is “open” to access but also the significance and affordances of “off-limits” and “off-the-grid” space on a whole drove the explorers to begin unravelling everything around them. Our gaze had been so indelibly altered that we could no longer see the city in the form presented, the spectacle had been decoded. The crew followed Rapp in believing that “...today’s infrastructure sustains the paranoid and waning civilization that will be tomorrow’s ruin” (Rapp, 2010: 34). Although, as Debord writes “[t]he construction of situations begins on the ruins of the modern spectacle” (Debord, 1981: 25), the crew had clearly found that “‘ruins’, both [pre and post utility] are characterized by certain ‘affordances’ that destabilise not only the functionalist body but the anti-functionalist also” (Smith, 2010: 112). Many of the places accessed had clearly been empty for decades and often the group commented when we were in places on how bizarre it was no one had ever thought to do this before.

After exploring around a dozen drain systems including the Westbourne, the Fleet and the Tyburn, the group was more than ready to go anywhere that would lend itself to surreal experience and the harder it was to get into, the better. Our introduction of a heightened vertical imagination into daily life opened up even more freedoms, possibilities and questions.



Figure 99. Author knee-deep in sewage, River Effra, South London, photo by author

### **New tactics: high invisibility and social engineering**

“Using simple credibility props, one can acquire near-universal trust and respect without doing a thing to deserve it...”

– Ninjalicious (2005: 37)

As Marc Explo taught me that night on St-Sulpice, construction sites are more similar to ruins than they first appear – once past the liminal zone of cameras, motion sensors and security guards, we are relatively free to do as we please. However, our methods of access may differ in these places. In gaining access to derelict areas, stealth is almost always the preferred tactic whereas infiltration requires more elaborate creative thinking, planning and group cooperation. When

entering other areas such as London's drain and sewer systems, we found that posing as construction workers (builders) proved very fruitful. As the street artist D\*face points out in an interview with Luke Dickens (2008a: 20):

The best camouflage is actually not being camouflaged and looking like you are meant to be there and pitching up in broad daylight, wearing a neon vest and looking like you are a worker and start painting a wall. You look like you have permission and who is going to question you? (D\*face, 13/10/05)

Londoners seemed to ignore the hidden vertical dimensions of the city not just in a physical but in a social sense. The middle class, true to its name, moves horizontally and overlooks most of what doesn't, including builders (recall the insight from the crane operator above). When we dressed up in high visibility vests and hard hats, we looked like we were at work and, in a sense, we were. In these instances, attitude was everything; our stealth tactics gave way to social engineering. During an infiltration of subterranean Paris, Winch and Dsankt had a discussion about it, with Winch suggesting,

“There are only two types of barriers we face, aren't there, the physical, which we have little problem with now, and the social. Social barriers can be overcome too; we just have to hone our skill.

Dsankt replied, “Yeah, we just hope the people who know what's going on don't show up in the meantime” (Winch and Dsankt, January 2011).

The first time I experienced this was with LutEx long before infiltration had become our *Modus Operandi*, when we entered a system of air raid shelters under Luton, north of London. My field notes from the day record my shock at his audacity:

*LutEx mystified me with his calm, organized and rational approach to the concept of what he called “overt camouflage”. He pulled his car up on the pavement, coned off the area, adorned himself with a high visibility vest and proceeded to wrap tape around the cones, creating a cordon, redirecting pedestrians and giving the site the look of a public works project. He then produced two drain keys which we fit into the split-square manhole, lifted it up and voila! 60 years of buried history was ours to experience.*



*I am interested in other ways overt camouflage could be used but also had another thought about this idea. Basically, this only works if you have the appearance of someone who 'belongs' there. This means that people with body jewellery, tattoos, even dreadlocks would become more suspect immediately. Which leads me to suggest that the real revolutionaries may not be the kids with purple mohawks, but the people who look quite normal yet work to resist banality through their thoughts, word and most importantly, actions, in more subtle ways (Fieldwork Notes, Luton, March 13<sup>th</sup> 2009, see video 4 – Luton Bunkers).*

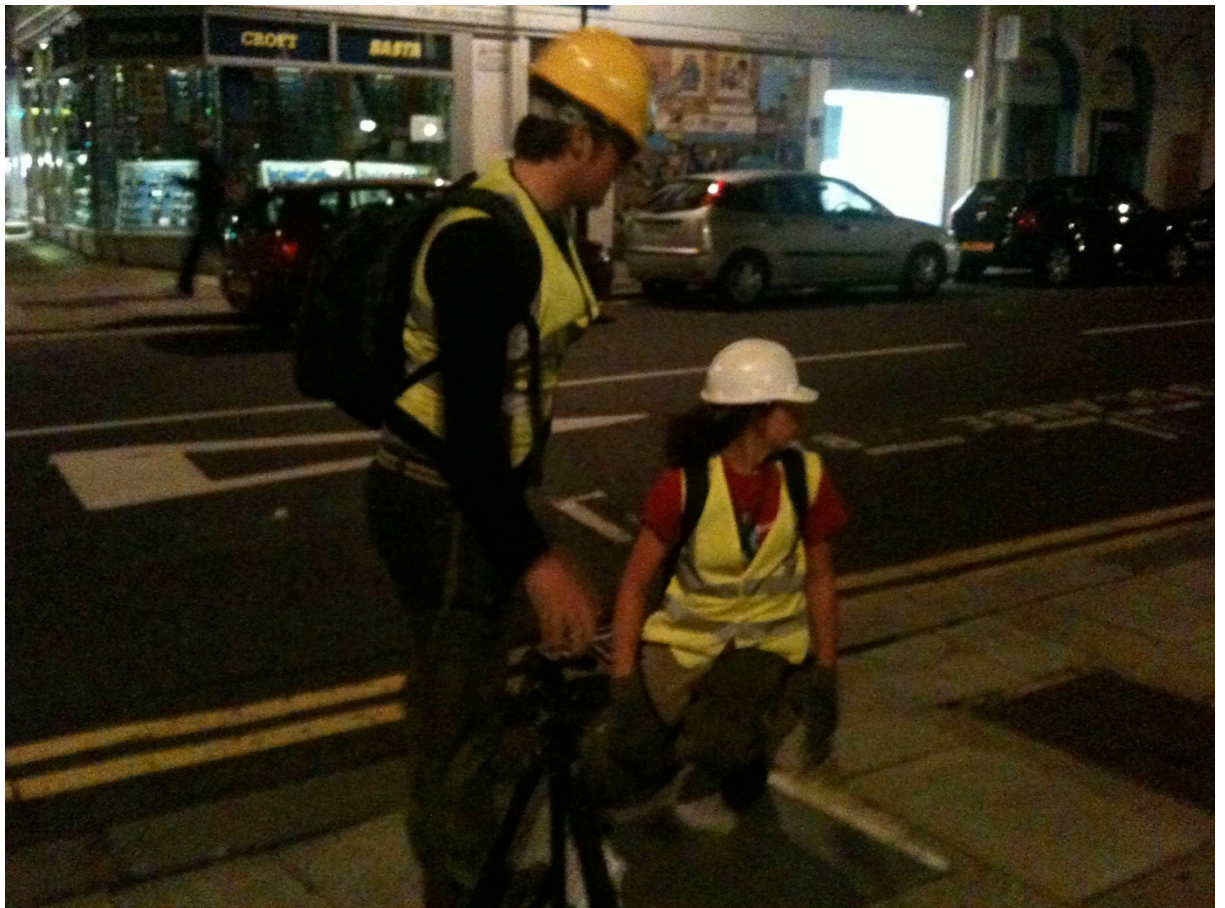

Figure 100. Winch and Neb in costume popping a lid, London, photo by author

Winch later commented on this when reading my field notes, saying, “yeah, it's shocking really how two years ago we didn't really understand this concept just yet. Now it's just part of how we work.” In fact, forays into the city dressed as, for instance, Thames Water workers, became so common that we often carried the uniforms in the boot of the car all the time, like work uniforms. On some level, we convinced ourselves that the “outside” was “in”, almost shocked when someone actually confronted us. In one instance, a drunken woman on the street in the City of London asked Winch why he had a hardhat and high vis on at 3am, he

responded, in all seriousness and slightly annoyed, “obviously we’re going into the sewer to take photos” (Winch, May 2010).

Organized transgressions against normative daily behaviour, what Oli Mould has termed urban subversions (Mould and Garrett, 2011), are in fact rarely riotous. Creative resistance in places may take the form of refusing to move where you are expected to, such as in a flash mob event where large groups of coordinated participants freeze in unison in public spaces designed for pedestrian flow (Wasik, 2006) or in rural areas designated private property where groups such as the Ramblers Association of Britain hold annual “Forbidden Britain Day” mass trespasses (Solnit, 2001: 167), a simple act of walking where you are not supposed to. Some incursions into places do not even take place physically, such as Trevor Paglen’s visual trespasses onto United States military property through the telephoto lens of a camera, or his more recent work called *The Other Night Sky* photographing US spy satellites that supposedly do not exist (Paglen, 2006).<sup>40</sup> Like many other activities, urban exploration, while conceptually provocative, would look almost dull viewed from the outside in when someone comes along on an exploration. A lot of time is spent, for instance, sitting around waiting for security guards to leave when we think they might have heard us or waiting 30 minutes for someone to take photos, moving lights around to achieve the desired aesthetic. The edge brought to the activity is in fact largely conceptual – it’s the notion that what is taking place, what the group is actively participating in together, is authentic life, whether or not anyone actually cares (or knows) that it’s happening.

---

<sup>40</sup> [http://www.paglen.com/pages/projects/other\\_night/index.html](http://www.paglen.com/pages/projects/other_night/index.html) (accessed 6th January 2012).

**Sneaking around, failing and getting busted**

“In a closed society where everybody's guilty, the only crime is getting caught.”  
 -Hunter S. Thompson (1998: 72)

**METROPOLITAN POLICE SERVICE** Form 5090(X)

Family name\* ..... GARRETT BRADLEY

First Name(s)\* ..... GARRETT

\*(if name not given, use space to give a description)

Gender M  F  DoB 01/04/1981 A/Age .....

EA Code 1 SDE Code 09 Height 58

Address 2848 MONUMENT DRIVE RIVERSIDE CALIFORNIA USA Post Code .....

Vehicle Type ..... VRM .....

Stop & Account Behaviour  Action  Possession of an item  Presence in area

Search Grounds SEEN CLIMBING ON A CRANE IN A BUILDING SITE ON TOTTENHAM COURT ROAD Oxford St.

Stop/Search Search (if different location)

Date 13/06/2010

Time 01:10

Loc'n Oxford Street

BOCU Code CW BOCU Code .....

Stop Only Code Search Code A Outcome Code 1 Arrest Code .....

Person Only Y  N  Vehicle Y  N  Damage caused\*  Injury caused\*

\*Details .....

Searching/Stopping Officer ..... 21051

Warrant/Pay No. 229872 B(OCU) ..... Team/Unit T13

MP 672/08 Copy for person stopped

Figure 101. A “stop and search” form received by the author from the London Metropolitan Police after being seen climbing a crane, image via London Met and author

With the increasing risk the group took also came an increased likelihood that we would be caught and/or put ourselves in dangerous situations, both above and below the city.

*In February 2010, I got a call on my mobile. It was Sunday evening and my friend Erika was visiting from Sweden so I ignored it and let it go to voicemail. Hours later, after a few pints in the pub, I checked the message. It was a garbled recording of Silent Motion sounding like he was underwater. All I could catch from it was “help” and “trapped”. Thinking he was taking the piss, I called him back and after many rings, he picked up. The conversation was difficult, I could barely make out what he was telling me. What I could eventually piece together was that Silent Motion, the most agile and sneaky of our crew, had gotten himself stuck in a lift at 100 Middlesex Street in the City.*

*I called LutEx who I knew had a handful of gear in the boot of his car for just such an occasion. He picked Erika and I up from Clapham and we raced to 100 Middlesex, arriving at about 10pm. We jumped the hoarding and quietly made our way to the lifts. Indeed, one of them was stuck on the 13<sup>th</sup> floor, the button unresponsive. We pulled out a set of lift keys but none of them fit this particular model. We then went to the stairwells and realised why Silent Motion had taken the lift (which we learned never to do early in our infiltrations, both for safety and the possibility of alerting security): the stairwells were boarded up tight.*

*We worked for hours trying to push the boards back without breaking them, not wanting to exacerbate the situation should the authorities get involved. As LutEx pointed out, even if we had gotten through the boards, there was no guarantee we would be able to pry the lift doors open on the 13<sup>th</sup> floor. We had to give up.*

*With no way to contact Silent Motion inside, we did the only thing we knew to do at 3am on a Monday morning in such a crisis – we called the fire brigade. The first time I called, the woman answering phones told me my story “was not amusing” and hung up on me. The second time, I was told they would “send a unit”. About 20 minutes later, 12 police cars showed up and walked into the building next door, talking to the 24-hour security guard. Clearly, the guard had seen us hop the hoarding on our way out. I then rang back 999 and told them “look, I am standing here now with officers everywhere, can you please send one of them into 100 Middlesex, this is not a joke, there is someone trapped in there”, explaining that I did not want to speak to the police in person as I was on a student visa. The receptionist assured me that she would make the call. We left before the police started looking for us.*

*Nobody slept that night as we waited for word from Silent Motion. Finally, at 10am, he called. He told us that neither the fire brigade nor police had come but a throng of workers greeted him when they turned the power to the lifts back on at 8am Monday. The site manager, not wanting to cause any “unnecessary paperwork”, sent him on his way after 48 hours trapped in a lift with no food. Although Silent Motion was appreciative of our efforts and very forgiving of our failure to rescue him, I had never felt so helpless in all my life. I think I will always be haunted by the failure (Field Notes, London, February 2010).*

In another instance, when I was out of town, Winch, Statler, Patch and Neb had a very close call in a Hastings storm relief system called The ‘Stinger, which Winch wrote about on his blog.

*We’d been here for perhaps 40 minutes, and with a roar coming from the infeed on the right, the waters suddenly speeded up. First they sloped up and over the edge of the walkway, then within 30 seconds they were flowing over the top and running down the walkways. With haste we*

*packed up and the others joined me from the platform on the right as the flow reached our calves, and eventually our knees. We'd had two choices. Either sit it out up high or aim to head down the 300m or so we'd come up the tunnel and away.*

*Neb's bag was carried away and we crossed the flow using slings wrapped round our wrists, the combined body weight of the group giving stability to the person deepest in the water. We shuffled down towards the exit with haste, the distance seeming far greater than on the journey up. Shadows and colours on the walls tricked us several times as we thought we had reached the exit, but only reaching stained marks on the concrete wall. Eventually we reached the infeed tunnel and had to wade up through a waist high flow, using an extended tripod to pull ourselves through to the ladders. We clambered up and out, grateful to be out of the sewer, as the thunder and lighting crashed around us. This hadn't been in the weather forecast, and certainly not in our script.<sup>41</sup>*

With the increased risk we were now taking to see more deeply hidden sites came an increased possibility of things going wrong, or even of one of us dying, falling from a crane, being hit by a train or drowning in a drain during a rainstorm (see video 10, *Crack the Surface*, 9:00). However, as David Heap writes about the similarly hazardous exercise of caving, the experience “stands for something real: danger, fear, romance, curiosity, physical exaltation are important components” (Heap, 1964: 22 cited in Cant 2003: 71). The risks undertaken in these types of infiltrations were deeply satisfying embodied moments of presentness where explorers were “forced to deal with the immediacy of the moment by responding ‘instinctively’ to the evolving circumstances. It is simply not possible to formulate, via the social mind, an effective response to a challenge that threatens to instantly overwhelm the actor” (Lyng, 2004: 362). Despite the terror of such events, they often become the stories worth telling. As Neb said to me about ‘Stinger,’ “there are a lot of people who have near death experiences but not many who have interesting ones” (Neb, May 2010).

---

<sup>41</sup> <http://www.thewinch.net/?p=849> (accessed 6th July 2010).

The requirement of self-determining action reinforces the power and agency of the individual over the situation, in contrast to everyday space where we are constantly under the influence of situations created by others (this is certainly the case for many people's lives at work). This is why Guy Debord of the SI insisted on the "creation" of situations we find to be "authentically real and creatively satisfying" (Lyng, 2004) to reinforce our place in the world as intentional actors. What is found in those moments of manufactured fear – keeping in mind we place ourselves in harm's way – (Pain and Smith, 2008, Saville, 2008, Tuan, 1979, see chapter 5) are times when the image of self, what Lyng (2004) calls the "dominating body", is dissolved into the embodied action of the situation or the "becoming body". Although we are always already becoming, our submission to the moment, indeed our submission to the embodied encounter with the very physical and changing matter of the city, provoked it to respond to us in exciting ways, where Deleuze sees the ethical injunction of the body being subject to the nonhuman flow of life, in this case, a vibrant urbanism (Zylinska, 2009: 29).

A collapse of the ego is experienced when explorers lose sight of self in moments of precognitive environmental action and reaction. Attempts to control the chaos of unstable and unsafe situations mark new urban terrain where the "...becoming body that cannot control chaos but rather is transfigured by chaos" (Lyng, 2004: 368). The reduction of those opposing forces evokes the becoming body, which is forced to grapple with surroundings in a way not usually experienced. Those moments are captured though the digital prosthetic (the DSLR), in the meld, when self becomes machine, city becomes body and where we as a collective become an event taking place – an anti-spectacle asserted through group consensus to cause and experience chaos. Returning to chapter 2, we might see the camera as in

inhibitor to experience where the technical process of photography takes precedence over experience. But again I will suggest that the camera can also augment the experience as a prosthetic even as it acts as a legitimisation prop.



Figure 102. Oh us? We're just photographers... photo by author

The explorers were, returning to chapter 3, rewriting that urban history of capital, investment, banking, construction, national heroes and government as a populist history “and what we make history with is the matter of a becoming, not the subject matter of a story” (Deleuze and Guattari, 1988: 347). That process of becoming is here captured in images with a particular style, a signature, thus “the aesthetics of style create new possibilities for resistance to the disembodied imperatives of the system. In making the transition from fashion and conspicuous consumption to style and aesthetics, the mirroring body is superceded by a becoming body that discovers new terminations of corporeal contingency in its complex appropriations of consumer objects” (Lyng, 2004: 370). To reiterate, the body is being formed through a constant pull between conformity and subversion

where “the body as a site of power, a node which is contested between forces of control and resistance” (Foucault 1979 cited in Fox, 2002: 348). Urban explorers tip the scale back into a more balanced state by extending the realm of intercorporeal possibility off the map and into the realm of uncertainty.

At times the crew had to trust each other in heated moments and in others submit themselves to the situation as “becoming bodies” where ego was transcended by the experience of surreal moments which threatened to overwhelm us as biological, sensory beings. However, “as one moves to the final phases of the experience, fear gives way to a sense of exhilaration and omnipotence. Having survived the challenge, one feels capable of dealing with any threatening situation. This no doubt contributes to the elitist orientation of some edgework groups” (Lyng, 1990a: 860). Lyng was right, as our list of successes as a group grew and our edgework pushed reconfigured the boundaries of the practice, it was impossible to ignore the smugness that arose with it. From the perspective of the urban exploration community we were now operating at the margins of, in the words of Urbanity, we were experiencing a “meteoric rise on the scene” (Urbanity, July 2011), both ostracised and admired. That ostracisation came with an assumption that in order to accomplish what we were accomplishing, we must have been committing criminal breaking and entering. Which was not strictly the case – in many instances, our successes came from better research, better planning, blind luck and the willingness to be caught if necessary.

Our increasingly arrogant attitude arose in inevitable confrontation with authorities in places where, not unlike our encounters with architectural resistance, some in the group enjoyed exacerbating an otherwise routine



encounter insisting that they, not the authority figure, were in the moral right. In Berlin, we visited the 1936 Olympic Village where half the site was a heritage park and the other half in ruins. With beers in hand, we slipped into the abandoned sections, snapping photos. When the park “security” came around and yelled at us to get out of the closed sections, we mocked them, yelling back “we paid our Euro” and continued on, knowing they were relatively powerless to stop us. A masochistic element of bodily asserting a right to place was increasingly in evidence. No longer stimulated by ruins, which, as Winch said above seemed a shallow physical challenge in terms of access at this point, the ego re-emerged in that absence of the becoming body in a vicious manifestation of I.

Later, when caught in more sensitive places such as on skyscrapers, group members tended to react with much more deference, apologizing to the police for wasting their time – as at times the police reaction was almost absurd, sending dozens of cars, vans and dog teams to give us a lecture and a stop and search form. Often though, encounters with workers in particular had no negative consequences at all (see *Crack the Surface*, Marc Explo interview, 2:16) as during an encounter with track workers (trackies) at 3am in an abandoned Tube station in Central London where they walked into Silent Motion. He wrote on the forum,

I think they were more confused than anything else - just walking the track then suddenly there's some guy with his face covered holding lots of camera gear, fiddling with a light fitting in a side tunnel (Silent Motion, UIS, March 2011).

Silent Motion politely said hello and absconded, leaving the pair standing in stunned silence. We later mused that perhaps it had made their night, something strange happening at work, and Patch ventured, maybe the trackies just really don't care as much as we thought they do, you would have thought they'd have

said a bit more than that” (Patch, UIS, March 2011)! Winch then added, “well, whatever [they] thought, they will have reported an intruder and they'll have sealed it on the back of that so we should still be avoiding those encounters” (Winch, UIS, March 2011). Clearly there was some joy to be found in “blowing their minds” by revealing we had gained access.

Those experiences, even when they led to arrests and, as I will soon show, worse, always resulted in an increase in skill level and awareness for future situations, causing an escalation of tactics when caught as well as an escalation in pugnaciousness when punitive measures were taken by authorities. Silent Motion later posted,

We might want to change how we react to these situations. We should gtfo (get the fuck out) when the shit hits the fan, but to avoid that happening too often maybe we should just slow down, be more considerate and realise there's no rush, even if our hearts are pounding like crazy” (Silent Motion, UIS, March 2011)?

Finding the edge in these situations was always a difficult balancing act between pushing the limits and not making irrational decisions that led to unnecessarily complicated situations (such as setting off an alarm that was easily avoided, resulting in police showing up). One of the ways in which this was countered was through skill specializations. Particular people became quite good at planning, others with ropes, and others at picking locks. We all settled into roles that were not only comfortable but vindicating in getting our place in the group. By late 2010, we operated with the tactics of an elite military squad. And for what the group intended to do next, those skills were going to be vital.



Figure 103. Gaining access to Down Street abandoned London Underground station, photo by author

## **The first grail - hacking the London Underground**

“Although born in a prosperous realm, we did not believe that its boundaries should limit our knowledge.”

– Charles de Secondat Montesquieu (1901: 31)



Figure 104. The infiltration of the London Underground, Down Street Station, London, photo by author

It wasn't long before Marc Explo's birthday party on King's Reach Tower we cut our teeth on Mark Lane, an abandoned station on the District Line between Monument and Tower Hill stations we accessed by squeezing through a small window under a restaurant we found open. It was the first disused London Underground station that "Team B" had done, despite the fact that Siologen and others on Team A had already explored a number of areas in the network and had generally been doing ARTS (Abandoned Rapid Transport Stations) for a number of years. Dsankt, QX, Sergeant Marshall and others had famously "demolished" the Paris Metro<sup>42</sup> before we even began in London, a story which went viral all over the Internet and, along with the Niagara Falls Tailrace,<sup>43</sup> was one of the holy grails that really defined the limits of urban exploration at the beginning of the 21<sup>st</sup> century.

I think it's fair to say that some of us feared our experiences in Mark Lane while others revelled in it. Those of us who lapped up the adrenaline rush of the trains

<sup>42</sup> [http://www.sleepycity.net/posts/252/Demolition\\_of\\_the\\_Paris\\_Metro](http://www.sleepycity.net/posts/252/Demolition_of_the_Paris_Metro) (accessed January 2011).

<sup>43</sup> <http://www.adventuretwo.net/stories/into-the-belly-of-the-beast> (accessed January 2011).

flying by on the District Line while we hid in shadows and photographed the light beams streaming through the tunnel became “Tube junkies” and were quite openly obsessed with finding more stations to explore – prompting Statler to tell me in a German ruin later that he just found it boring now; “when you become obsessed with the rush of the Tube it’s hard to go back” (Statler, April 2011). Dsankt told me a few months after Mark Lane, when it was clear we were going to carry on exploring Tube, that “the real exploration begins once you get over that initial dereliction fetish” (Dsankt January 2011) and he was happy when we arrived on the playing field.



Figure 105. Our first disused London Underground Station infiltration, Mark Lane, London, photo by author

Soon after Mark Lane, our crew (still “Team B” at the time) cracked the City Road station. It had never been done before and once we had done it, others followed. City Road did a lot to establish our credibility as a crew and we encouraged us to then explore Lords station, running the tracks when the current to the 3<sup>rd</sup> rail was

switched off for the night to the connecting stations at Swiss Cottage and Marlborough Road.

Reformed as the LCC after Marc's birthday, there were over a dozen of us up every night doing Tube. South Kentish Town, Brompton Road, Marlborough Road, Old King's Cross, York Road, and Down Street followed rapidly. It was a full-scale assault on Transport for London's security, we were finding openings into stations so fast TfL could not keep up, though often they would board up access only days later, so we knew they were aware of our nightly escapades.



Figure 106. Signage at Lord's disused station, Metropolitan Line, photo by author

Those of us who began taking greater risks soon realised that *not only* were there greater rewards to be had but that there was a possibility of a holy grail at the end – the completion of the entirety of the disused parts of the system (18 disused

stations, 2 abandoned platforms and 9 stations for the mythical Post Office “Mail Rail” system). Siologen put every station onto maps and a text file and we shifted entirely from exploring “sites” to striving for completion of an entire urban transportation network.



Figure 107. Checking the tracks at Lord's disused station, London, photo by author

My final Tube exploration, before I left to write up, was with Winch, Statler, MC Nebula and Siologen in Down Street Station on the Piccadilly Line. An entry from my field notes depicts the night,

*It was about 11pm in February 2011 when I found myself walking from Green Park Tube Station into a swanky bit of London toward Hyde Park Corner. It seemed the least likely place to undertake an infiltration of the Tube but the last few months, given all we had actually accomplished, made me sure that regardless of the circumstances, we were going to get in. In my backpack, I had a massive cordless drill with a cross head bit on it, a razor, tape, a bunch of zip ties, some screwdrivers and my usual assortment of camera gear, lenses, tripod, gloves and lights. It was really heavy and jabbing me in the back. By the time Statler, Siologen, Winch*

*and Neb showed up, I was well ready to get on with it. Neb, Winch and Siologen kept watch when Statler and I slipped down a side alley on Down Street. A small board with 8 screws through it was pinned to the side of a grate. I quickly removed the drill and zapped each one as Statler grabbed the screws from the asphalt where they fell. The noise was horrendous. The board now off, we pinned it in place with a brick and walked back to the street. Neb assured us no one had seen. We all walked off down a side street where there was a small builder site and stashed every piece of equipment that might look incriminating if we were caught, though we hadn't technically broken anything. Then, altogether, we walked back to the grate, and slipped in.*

*On the other side, we were greeted by glowing control panels in a dank room. The floor was a mesh metal grate that gave a bit when we walked. As Siologen was pulling the board back behind us, I heard Statler say, "shit, they've locked up the hatch." I looked down where he was standing and saw it was indeed locked. Winch then looked up and said, "looks like we're going over then." We climbed over a 5-meter high gate and dropped down on the other side where we could get hold of a ladder. At the bottom of the ladder, we sat on a concrete ledge with a straight 20-meter drop into darkness. Every few minutes, a train on the Piccadilly line would fly through the tunnel underneath us, pushing a warm wind laced with black dust into our faces. Having no ropes, we carefully grabbed onto the bolts holding the structure of the shaft together, along with some rusty pipes and began the descent.*

*Layer after layer, we had to continually overcome small problems in access, closed hatches, locked gates. Finally though, we emerged at the bottom of a set of stairs and realised we had done it – another Tube station had been cracked. We patted each other on the back, smiling madly, and began unpacking the camera gear. We hid from the train drivers as they sped past in small nooks, all of us now knowing the rhythm of the trains and method of hiding as intimately as we knew our camera gear after doing a so many stations together.*

*We had planned the timing of this infiltration perfectly and as the last train on the line went by, followed by a work train, we watched the glowing panel next to the tracks as the TfL workers turned off the power to the third rail, also the trigger for the lights to turn on in the channels. We then spilled onto the tracks, quietly jumping the rails and running off into the tunnels. Previous experience told us we had about 15-20 minutes until the trackies arrived to do inspections and we made use of all of them, running into side tunnels, running into each other, laughing and adeptly setting up the tripods in waves like a volley of rifle fire, moving together so as not to get in other's shots for 10, 15 and 20 second exposures. Without speaking, everyone knew when it was time to leave. Gear went back into bags and we made the slow climb out.*

*After retrieving the drill and securing the board again out on the quiet London street, the only material reminder that we had ever been in Down Street was a small "explore everything" sticker that I always leave*



*behind, tucked in the station where the next explorer would find it. We sat in Green Park at 2am and talked for hours, celebrating yet another disused Tube Station brought to light. We all knew it was only a matter of time before we had seen them all. The high lasted for days (Field Notes, London, February 2011).*

Between 2008 and 2011 we completely reconfigured the boundaries of London urban exploration. Other crews scrambled to keep up, hitting stations we had cracked right after us. As Otter writes about our conquest of Down Street, after the consolidation, through individual ambition and collaboration, once we decide something would be done, “the unconquerable was conquered” (Otter, March 2011). And as Brickman so gracefully added, “TfL would fill their pants if they came across what we get up to on any given night” (Brickman, March 2011). I also like to think they would respect it immensely.



Figure 108. Kingsway tramway, London, photo by author



Figure 109. The "Holy Grail" of the London Underground, Aldwych disused station, photo by author



Figure 110. Silent Motion in the "Magic Door", London, photo by "Gary"



Figure 111. Down street disused station, London, photo by author



Figure 112. Passing train on the London Underground, Down Street disused station, London, photo by author



Figure 113. The author on the tracks of the Piccadilly Line, Down Street disused station, London, photo by author

Only track workers could truly understand the depths of the Tube and train fetish we had developed and clearly only a group with a great love for the city would spend all their free time studying old Tube maps, mapping locations, finding access and working that hard to bring them all to light. After a year of cracking the system open nightly, we probably knew more about the London Tube network through illegal infiltration than many of the workers in the system. Patch joked one night,

If I'd filled my head with knowledge that's actually useful rather than endless information about the Tube then maybe I'd have come up with an amazing idea or business model and become a millionaire by now (Patch, June 2011).

Even though much of it remained unpublicised, information travelled quickly via word of mouth within the wider London community, online and off, on secret forums and public ones. Speed, a London explorer on *28 Days Later* later wrote,

*I think most people could see it coming... the whole scene in London is really on its toes right now. You have a large group of very capable [people] who are not afraid to take big risks and push into stuff people have previously only skimmed the surface of. It was only a year or so ago one of the main protagonists was telling me how he was moving to London and was going to 'batter the tube' and things to that effect. A year on and he's done exactly what he said with success even an 'optimist' such as myself didn't really see coming. That's the sort of thing I've got a lot of respect for.*

*Focus gets you a long way* (Speed, July 2011).<sup>44</sup>

Group dynamics were further solidified by undertaking this work together, as well as through our collaboration on a now very concerted goal – achieving a complete exploration of the entire system. I would not be there to see it as I needed to go begin writing. However, just before I left London, I had one more goal that I was aching to achieve, an exploration that I saw as the ultimate test of our nerves and abilities. I called the crew to see if we could make it happen.

---

<sup>44</sup> This thread was viewed in July 2011 and was removed as of January 2012.

## Unsecuring Iron Mountain secure file storage

“When the going gets weird, the weird turn pro.”  
– Hunter S. Thompson (2003: 530)



Figure 114. An Iron Mountain security archive van transporting documents, photo by Sarah Hg

Underneath South London, from Clapham to Stockwell, there rests a series of disused shelters as deep as the Tube, four in total. The Clapham North shelter was a site of serial trespass, where in March 2011, the crew threw me a going away party as I left to write up. Just before that however, I was determined to gain entry to another shelter, given I lived so close to it almost my entire time in London and had never seen what was inside. In all honesty it was eating me alive, not knowing, a symptom of seeing all we had seen and yet having this heavily secured historic location right next to my house. I couldn't stand it. But I also had another motivation. The shelter I wanted to see was no longer disused, it was being rented by a secure file storage company called Iron Mountain. I asked the crew if they

would be willing, given all we had done with live infiltrations on the Tube in the preceding few months, to see if we could sneak in and rummage through the files.

*I went in the afternoon to the airshaft leading down to the shelter with a duffle bag and a crowbar. A restaurant next-door had put a number of pallets out next to the shelter. I knocked on the door, holding the crowbar and dufflebag and asked if I could break up some of the wood to burn at home. "Sure!" they said, happy to get rid of it. I piled the wood between myself and the street to hide myself from view and immediately took the crowbar to the lock on the door, ripping it off the hinges. I then put the hinges and lock in my bag, threaded a chain on the door through my own lock, piled wood in the bag on top of the crowbar and walked off with Marc Explo and Otter who were waiting across the street.*

*Statler wrote on the forum, "access involved brad chopping some wood (Tankcatting the lock) outside the door of the vent shaft.... cue Brad sending txt's to people letting us know that he had "chopped Wood" and that the vent shaft was mysteriously open" (Field Notes, date omitted).*

Six of us returned at 3am where Statler again writes:

*Luckily I was in town with [Patch] and ["Gary"] and had 50mtrs of rope and abseiling gear in my car, more msg's were sent and [Silent Motion] soon arrived on his push bike and we sent him down the big black hole shortly followed by Brad and then [Patch] the pack mule who abseiled down the pitch black shaft with 3 heavy bags and 3 tripods attached to his body somehow, it was a fast abseil down for him I believe! [Silent Motion], Brad and [Patch] then crawled through the smallest of vent ducts to bypass a padlocked steel door and then systematically remove all the magnetic door trips and open the Firedoor for me, ["Gary"] and later Marc and [Otter].... (UIS Forum entry, date omitted).*

Once inside, we had disabled the magnetic reed switch alarm systems on the doors, following a technique from Ninjalicious' book *Access All Areas* (Ninjalicious, 2005: 126-127) and, finding that the PIR (Passive InfraRed) sensor alarms were apparently not working, had free access to an entire bunker full of potentially sensitive documents. In the end, we all joked about how useless most of what was in there actually was and left almost bored by the end of the night. However, the successful infiltration of this bunker proved that we had veered far from the public conception of "urban exploration", both in skill level and motivations; we were place hackers.

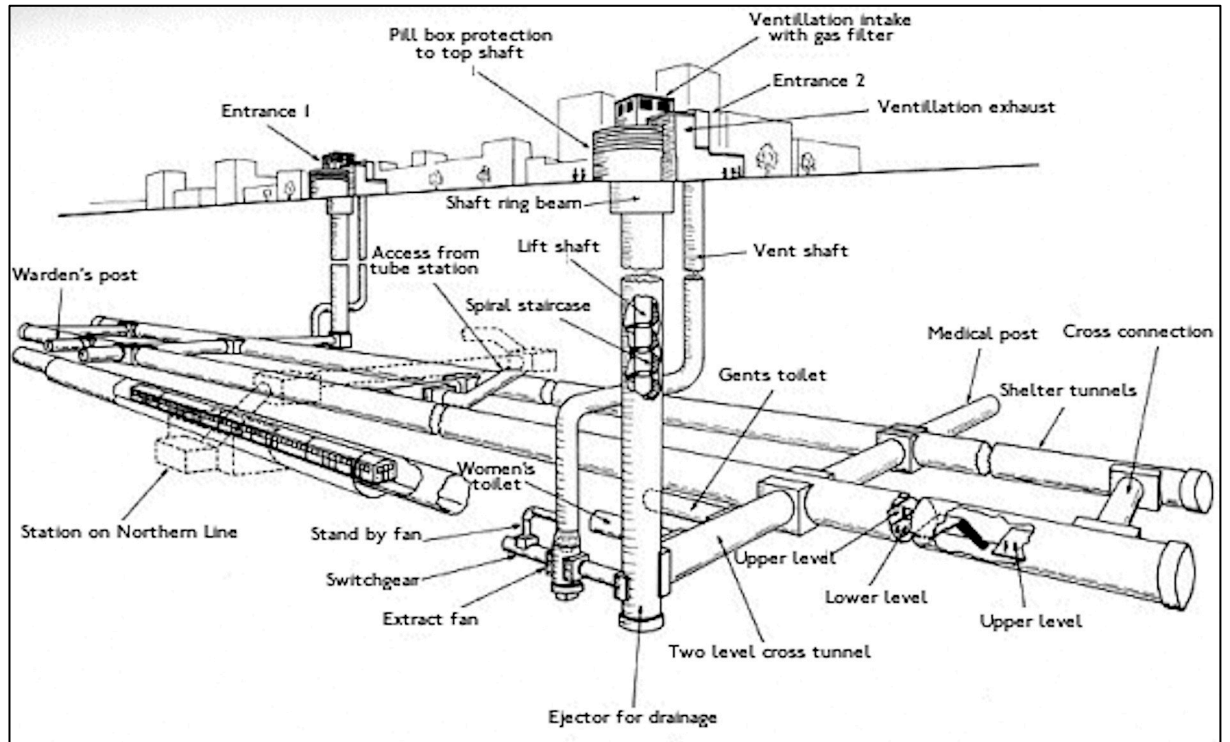

Figure 115. The subsurface layout of a London deep shelter, photo via <http://underground-history.co.uk/shelters.php>



Figure 116. Silent Motion abseiling into a secure file storage through the ventilation shaft, London, photo by author





Figure 117. The disabled magnetic reed switch door alarms in the secure file storage, London, photo by Silent Motion



Figure 118. Successful access to Iron Mountain's security archives, London, photo by Silent Motion

Just weeks after the Julian Assange Wikileaks scandal, when he appeared in a London courtroom for disclosing government secrets, we had gained entry into a secure file storage area, rummaged through the documents and photographed everything potentially “sensitive” we could find. I imagined Assange would have enjoyed knowing this was happening, his ethos for transparency so closely aligned with ours. We never wrote about it publically, knowing what a scandal it would provoke within the UK urban exploration and beyond, especially after the Burlington incident that now seemed a lifetime ago. However, I think it is important to write about it here and reflect on what it meant for us as a crew to do something that was purely for the joy of doing it, purely for the adrenaline rush, for what could be the historical value in seeing a shelter exactly like the others we had already seen, aside from the fact this one held secure files? In terms of Siologen’s early comments in chapter 1 about urban exploration being a victimless crime, I couldn’t help but wonder – what were the eventual consequences of Iron Mountain finding out their secure file storage area had been breached, locks replaced and alarms disabled? Did they have to tell of their clients that there had been a potential document leak? Did they have to inventory every document in the bunker to see what had been taken (for surely, what else would be the motivation)?

We laughed about it for weeks, leading Winch (who was out of town when it was cracked) to comment that “this sounds like the heist of 2011 so far” and Brickman to reply with “now it’s been explained, it sounds like a job even professional bank robbers would have been proud of...” Statler, finally, half-joking wrote “This forum is turning into [www.urbanburglaryscene.co.uk](http://www.urbanburglaryscene.co.uk)” (Winch, Brickman and Stalter, UIS post, date omitted). Although we made light of the situation, the implications for us as a group were becoming quite serious, as we will find out in the next chapter.

**Professional infiltrators, leaking spatial secrets**

“Our particular view on the mechanism of transparency is to selectively go after material that is concealed.”

Julian Assange (2010)



Figure 119. Security breach: the author flipping through Deutsche Bank archives, London, photo by author

Lefebvre has written that the organization of space is never neutral, it is always entangled in complex power arrangements (Lefebvre, 1991) and in contemporary urban environments, an attempt is made to code space to invoke particular responses predictably conducive to the acquisition and accumulation of capital. Edensor points out that “perhaps it is in the contemporary Western city that... tensions are most evident, the site of an ongoing battle between regulatory regimes concerned with strategies of surveillance and aesthetic monitoring, and tacticians who transgress or confound them, who seek out or create realms of surprise, contingency, and misrule” (Edensor, 2005a: 829-830, referencing de Certeau, 1984). Although one could see these tacticians (of whom urban explorers are one) as opposing dominant narratives in a traditional Gramscian formulation,

as Alastair Bonnett writes, “merely to oppose social representation is to become a part of the spectacle” (Bonnett, 1989: 135). The nature of subversion, and the power of urban exploration, is in its subtlety. Like the Situationist *dérive*, the practice appears to be playful, comical, even pointless, yet it’s an indication of a possibility for alternative options. In the case of the secure file storage, for instance, we did not speak about it or release pictures – the only indication we were ever inside was an extra padlock on the air shaft, a few taped up alarm strips and, of course, an explore everything sticker on the fire exit. But every time we drove by it leaving the house, we delighted in the secret we shared with the place and in the thought that the property owners might not even be aware we had disabled their security and infiltrated their bunker.

Given Edensor’s suggestion that this, the here and now, is the place and time for subversion, perhaps it comes as little surprise that urban exploration emerges in the midst of a cluster of growing urban interventions developed to (re)seize agency where freedoms “appear to be constantly under attack in the modern city, constantly circumscribed, constantly surveilled – often enough in the name of freedom, service and protection” (Pile, 2005: 8). Urban explorers seek not to dismantle what Deleuze (1990) termed the “society of control” but to playfully subvert it and raise awareness on what possibilities are available to urban inhabitants within the structure of the system, even as it may serve as a (perhaps underarticulated) critique on the illusory nature of control over and security within that system. Whether or not explorers choose to vocalise it, I follow Rapp in suggesting that urban exploration, while hacking into the cracks in the urban façade seeking freedom of experience and expression, “...is an index to assess the

intensities of security, control, and surveillance in the contemporary urban environment” (Rapp, 2010: 4).

Although I have shown urban explorers are not largely anti-capitalist, within capitalist systems, the invitation to coproduce place often has a price or the output of that production is expected to become commodified. People begin participating in informal modes of cultural participation out of a desire for human bonds to take precedence over outcome and production, seeking becoming over being and community over capital. Rather than asking to be involved, as Marc Explo exerts,

We just figure it out for ourselves don't we? And once we know that, once we know we could cripple this city in an instant, take whatever we want, then we are empowered, then we are citizens. I don't need the state to offer me a say, I already took it.



Figure 120. Security glitch located at Abbey Mills pumping station, London, photo by author

By the middle of 2010, the Internet was awash with stories of LCC successes. We were receiving a steady stream of media request from production companies, newspapers and even the BBC<sup>45</sup> and hate mail from UK explorers condemning for becoming arrogant in our success - which we were. But the crew took little notice – they were too busy continuing the search for the British Telecom deep level tunnels, the London Mail Rail and finishing off the last Tube stations on the list. On “nights off”, they were in the sewers, mapping out systems and finding new junctions or climbing cranes we had already done simply to take a break and have a beer. London was transformed into a nocturnal playground.

Returning to chapter 1 and thinking again about whether or not urban exploration can be thought of as a global community of practitioners, something interesting began to happen in 2010. While the UK community was busy condemning the LCC for what they assumed was a blatant and constant violation of the code of ethics and an increasingly arrogant attitude toward the rest of the UK scene, we began getting messages and online social network friend invites from groups of explorers in other parts of the world. Soon we had made ties to New York, Milan, Paris, Stockholm and Minneapolis and were receiving encouraging messages from other groups who had broken away from the “scene” to start carving their own paths. We had, in a sense, joined a blossoming global group, an inner sanctum of urban explorers I never knew existed when I started my research in 2008.

Given my initial stumbles with this community just 2 years before, our “meteoric rise on the scene” (Urbanity, July 2011) caught me almost by surprise. I was so embedded with the crew that I had almost forgotten I was here to make sense of

---

<sup>45</sup> <http://bbc.in/iz9eYL> (accessed 24 January 2012).

the practice. What began to be revealed in 2010 was something I knew no other researcher interested in urban exploration knew much about – I had made it, in terms of my research goals but more importantly, as a member of one of the most successful urban exploration crews in the world which, not insignificantly, we had built together.



Figure 121. Nocturnal hospital infiltration, London, photo by author

From ruin exploration to increasingly elaborate infiltrations, the group was working toward goals that do not require sanctioned consent and are, in the framework of late capitalism, largely pointless. To us, they came to mean everything. Similar to Luke Dickens' work with street artists, our new projects looked more like social engineering as we probed the potentials of costumes, affected accents and props, what LutEx called "high invisibility" back in 2008 and we became increasingly adept at sneaking around, using ropes, picking locks, temporarily disabling alarms and CCTV cameras and finding very tricky access points we would not have noticed years earlier. These escalations in tactics prompt

an important question – how would this “golden age” conclude? Did the crew have any chance of winning this arms race against the forces of control and surveillance in the city before they were caught?



Figure 122. The author having a beer and listening to NASA radio feeds in in a crane cab, London, photo by author

Before answering that question, in the next chapter I am going to address yet another aspect of the practice to further complicate these necessary empirical components. After the whirlwind ride we have taken into new forms of infiltration that radically challenge the notion of what urban exploration might consist of, I want to spend time highlighting the important embodied component of urban exploration, given it is often depicted as a disembodied representational practice (Bennett, 2011). Our move into disparate, tactile, and exhilaration-driven forms of exploration were if fact, I will argue, an effort to increase our sensory indulgences and range of possible interactions with the city. To do so, we increasingly worked by feeling even as we became more skilled and persistent.



## Chapter 5 – Recoding the city through bodywork

“All art is at once surface and symbol. Those who go beneath the surface do so at their peril.”

– Oscar Wilde (1998: 3)



Figure 123. Infiltration of infrastructure offered new possibilities for bodily damage, GLC pipe subways, London, photo by author

Due to urban explorer's obvious preoccupation with the visual media technologies, described in chapter 2, and exhibited throughout this thesis, the practice would seem an easy target for those who insist that many modern practices are rooted in a visual bias, carried over from the Western tradition of foregrounding the visual over other senses (see Jay, 1993, Macpherson, 2005, Cosgrove, 2005, Driver, 2003) at the expense of multisensuality. Photography is obviously a core aspect of group participation, engagement and shared interest in this practice and McRae contends this has already become problematic because,

Fixation on image and a specific aesthetic of decay indicates that urban exploration and the transgressive spaces it explores might already be moving towards Baudrillard's (1998) signed and symbolised economy (McRae, 2008: 158).

In other words, the overwhelming fixation on representations is a sure sign of spectacle appropriation in progress. However, in this chapter I will explain that while images dominate the depiction of this practice, they are also the other side of an embodied practice, often overlooked. Urban exploration uses a range of tactics and strategies (following de Certeau 1984 and Bourdieu 1986), both distal (visual representation) and proximal (tactile encounter) (Dixon and Straughan, 2010), to hack its way into and reconfigure places so that they feed into the identity of the explorer even as the explorer multiplies their stories to create myths, dreams and visions of a present moment of possibility available to those harbouring desires to make them manifest. Moss and Dyck describe embodied space as “an intellectual space from which identities may be reformulated... from which to challenge binary and ‘fixed’ social categories...” The body that chooses to enter these places then becomes “a discursively produced body which is constantly lived through both its materiality *and* its representations...” (Moss and Dyck, 2003: 67, emphasis mine), and this seems to me a good description from which to begin.

The important point to make here, in response to those who insist that urban explorers are entrenched in the visual to the degree it has become the primary motivation of the practice (High and Lewis, 2007, Bennett, 2011), is that without the embodied aspects of practice, without human relationships, without physical architecture and without, as Marc Explo contents “action!” urban exploration could not take place; as McRae writes “explorers share Lefebvre’s belief that change can only happen through action in space” (McRae, 2008: 78). A photo of exploration is then, as Hetherington describes, a “haptic reaching out and does not presume in advance the necessity of an engagement in the act of visual representation, let alone its outcome as knowledge that can be communicated discursively to others”

(Hetherington, 2003: 1937). Other explorers do rely heavily on the production of “fantasy” representations such as the ones discussed in chapter 3 (RomanyWG, 2010), however my ethnographic experiences with explorers have always foregrounded those proximal, tactile, pathic pathways. So, in this chapter on recoding the city through bodywork, let us begin with a discussion on the relationship between body and place.



Figure 124. Bodies in action, West Ham Storm Relief, London, photo by author

Discussion of embodiment within geography frequently incorporates enticing phenomenological discourse, calling forth Heidegger and often references Merleau-Ponty's *The Phenomenology of Perception* (Merleau-Ponty, 1962). In the text, Merleau-Ponty makes an impassioned argument for the foregrounding of embodied, haptic, subjective experience, exhorting readers to “plunge into action” (Merleau-Ponty, 1962: 110-111) but, as scholars have pointed out (Cresswell, 1999), does so at the expense of the object against which the actor is to “plunge”, reinforcing a problematic structural binary of self and other, subject and object.

Merleau-Ponty also levels all bodies, not taking into account issues such as gender and disability (see McRae, 2008), making “the body” a singular entity capable of action.

However, the faults we may find in the arguments of the phenomenologists should not preclude us from thinking about the important ways in which we think and act through the body. Geographers writing more recently on embodiment have worked to meld the subject/object binary and to recognise not only the effect of the acting body on place but also the effect of place on the body, where the encounter between bodies and places creates new “sensuous dispositions” (Lorimer, 2005: 85), porous encounters of bilateral exchange. These sensuous dispositions are always contextual, always a negotiation between a range of characters and affectations, bodies and presences, people, places and things where “we need to explore how we feel – as well as think – *through* the body (Davidson and Milligan, 2004: 523). On this project, nowhere were we more aware of thinking through the body than inside the Tube network where one mistake, such as tripping on the 3<sup>rd</sup> rail, may have been fatal.

The embodied synaesthesia of intimate body/place/thing/time is the urban exploration praxis, the point where thought and action collide in place. It is the most important indicator of what Silent Motion, Winch and even Oxygen Thief have asserted throughout this thesis – the primacy explorers place on lived experience *and* representations, perhaps surprisingly given the overabundance of modern explorer imagery online.



Figure 125. Silent Motion and Keitei sneaking into the London Underground, photo by author



Figure 126. Running the tracks from Lords to Marlborough Road and Swiss Cottage disused Stations, London, photo by author

Although social credibility is gained through sharing photos as an indicator that one was “there” (the reason why so many explorers take photos of their bodies in places or “people shots”), tales of urban exploration are also not published. They are rather shared through storytelling, often while exploring. As an example, I now turn to a field note entry from an exploration of a derelict Russian submarine I often retell when people want to hear about an exploration “gone wrong”.

*I got a call from Hydra one night when I was at home, explaining that she had heard there was a derelict Soviet submarine, a U475 Black Widow, sitting in the middle of the Thames somewhere near Rochester. Telling that she had purchased an inflatable dinghy off eBay for 30 quid, she asked me if I wanted to meet her there to see if we could get aboard and inside.*

*I arrived in Rochester at about 11pm, stepping off the train to find an unexpectedly sleepy little Dickensian town. We made our way to the riverbank by midnight and found a small set of wet stairs covered in green slime just at the waterway that would shield us from the eyes of passing drivers. 30 minutes of absurdly loud dinghy hand-pumping ensued, leaving my arms completely sore and limp by the end, not just from pumping but from fending off the trash getting washed up onto us where the tide was rippling against the shore. Finally, with the boat pumped and loaded with our equipment, Hydra in the front, I shoved off the river wall and plunked down in the back. In the silence of the night, floating into the middle of the Thames, the first thing we noticed was a terrible hiss coming from the boat. We were sinking. Both of us, in a panic, decided quickly to try and reach the sub, about 100 feet away, where we could repair the boat. I paddled fast and hard, working against a strong current and when we came speeding into the hull, Hydra tried to stop us with her oar, snapping it in half. We both watched solemnly as the broken paddle floated out to sea with the ripping current.*

*I grabbed a mooring rope and tied off the dinghy. When we both climbed out of the boat, scaling the side of the sub, the hissing stopped. Up top, we found the hatch covered in pigeon shit inside a small enclosure. Holding my breath, I slowly wrenched the handle and opened the hatch with a horrendous sucking sound. From inside, an oily, mouldy crusty pigeon olfactory cocktail hit us full in the face. We descended. Inside, the air felt compressed. It was a satisfying aroma of oil and machines, rust and decay, driftwood and dead bird. We played with the defunct radar, used the periscope and telephone and had dinner in the bow. The sub was resting unevenly on the hull, so walking required using an off-kilter sense of balance and setting up photos was almost pointless as they all turned out wonky and the space was very*

*tight. After a good five hours in the boat, both our heads began to hurt - I think from breathing the stale air. We decided to leave.*

*Hydra was first up the ladder where we had left the hatch open. As she reached the top, swimming in darkness above me, I heard a horrible thud followed by a blood-curdling scream. She came down the ladder in a limp pile, falling on top of me, holding her head. The hatch, just as she was poised to leave, had swung shut, the sealing wheel hitting her hard. After she took some time to recover, both of us becoming increasingly paranoid about our headaches and the stale air, we worked together to get her to the top.*

*With the swirling black and tan Thames around us, she was dizzily wandering toward the dinghy on the slippery hull. I ran to grab her and at the moment I did so realised, with horror, that the tide had gone out while we were in the sub. With only one option left, I helped Hydra into the boat, got in myself (oh yeah, that hissing!) and paddled as fast as I could toward the shore. We beached the dinghy at some speed and I jumped into the mud to find that I sunk to my knees. We were at least 15 meters from the slippery stairs. Holding Hydra up with one arm, dragging the dinghy full of kit with the other, we slowly made our way to the shore, step by step with the horrible stinking sucking sound announcing our progress to a dismayed early morning jogger standing on the shore with his mouth open. Finally on the shore, we fell to the ground panting, laughing like mad. What a great Saturday night out (Field Notes, Rochester, UK, June 2009)!*

Urban exploration is not a geography of the body but a geography *through* the body, with a particular attention given to the unique sensual experiences that these hidden places offer, but, as I will show in this chapter, not necessarily limited to our biological sensory system or empirical rationalisations.

While feminist scholars like Judith Butler have written about the ways in which individuals may contest the social conditioning embodied within them by others, in the case of urban exploration we find individuals contesting the expectation of that social body (the habitus in Bourdieu's language) by putting their bodies in places they are not supposed to be (Cresswell, 1996, Mitchell, 2000), making an important move from embodied victimisation to embodied empowerment.



Figure 127. The mothballed Russian U-475 Black Widow submarine, Rochester, photo by author



Figure 128. Hydra playing inside the Black Widow submarine, Rochester, photo by author



The body in this case is also, it follows, not subject to the whim of the senses as much as testing the boundaries of those senses, probing, hacking, plying. Cresswell describes Bourdieu's notion of the strategy as "human action that marks a break from structuralist suppositions of 'agentless actions', which are more or less unconscious" (Cresswell, 1999: 177, discussing Bourdieu 1985) to produce new, unexpected actions and encounters. Sensory engagement, in this light, can be seen as yet another strategy in which the urban explorer seeks to subvert normative life in late modernity. Inside a derelict factory in Germany, a number of us stumbled into a toxic waste pit littered with oil pools, green water, toppled barrels of pink powder and animal corpses. The haptic horror of the moment caused a collective sensory shortcircuit. Gagging and coughing, we fled, smiles all around. The immediacy of the moment encouraged us to choose to go back one more time to see if it really was that delightfully horrible. It was.

What I am describing here is in contrast to much recent embodiment literature focusing on the "everyday" (de Certeau, 1984, Edensor, 2002, Frers and Meier, 2007, Harrison, 2000), instead following the work of researchers focused particularly on disrupting the everyday (Loftus, 2009, Pinder, 2005a, Pinder, 2008, Vaneigem, 2010, Bonnett, 2009), though of course making the everyday interesting can be accomplished through far less dramatic methods. This type of bodywork forces encounter with taboo realms and forbidden sensory confrontation at great risk that, again, undermine social notions of what is acceptable or even possible. Following the work of Kristeva (1982) Smith and Davidson write,

The embodied emotional experiences exemplified by sufferers' gut reactions to specific phobic objects both replicate and express, albeit in an extreme form, something of the underlying logic of contemporary society . . . The severe, felt disruption to the phobic individual's bodily hexis and mental health is indicative of, though not necessarily caused

by, tensions within the symbolic ordering of the larger social “body” (Smith and Davidson, 2005: 46, quoted in Dixon and Straughan, 2010: 453-454)

Exploration of forbidden space confronts individual fears, which can be a liberating experience, but also confronts material stigma, an embodied subversion which decodes aspects of the social body. Upon seeing photos and videos of people exploring sewer systems for instance, touching objects, drinking the water and playing in a space popularly conceived of as “dirty” and “untouchable”, static is introduced into the generally accepted notions of what we are told is taboo and what is actually possible.<sup>46</sup>

Using the body as a medium to transmit a message of quiet social subversion, the explorer softly insists on the right of the individual to decide to engage with urbanity in different ways. Ninjalicious (1999: 2) writes that while some curious people are content with a peek at a construction project, others “need to touch it, climb it, smell it and examine every minute detail in depth and figure out how everything works”. The same can be said for our fetishized infrastructural networks such as cable tunnels and sewers. Everyone need not take the functioning of those systems for granted, one can choose to enter them and begin to decode the mysteries behind the urban metabolism (Gandy, 2004, Kaika and Swyngedouw, 2000, Graham and Marvin, 2001, Graham and Thrift, 2007).

---

<sup>46</sup> See <http://vimeo.com/2890081> for footage of Siologen playing with a dead rat in the sewer (accessed December 2011).



Figure 129. The author and Silent Motion confronting the wretched, "stoop" sewer, London, photo by author



Figure 130. Absolutely filthy! Silent Motion in the River Effra, London, photo by author

Further transgressions against social expectations, such as taking nude photos in forbidden places (Binnie, 1992), also empower explorers through their active engagement in reconfiguring places in an image of their choosing, one that may be, in opposition to normative behaviour “in place”, highly sexualized, covered in dirt and toxic chemicals, illegal, suicidal, inebriated, forceful, playful or disrespectful. At its most basic level, urban explorers are “bodies out of place”. Importantly though, where often the categorisation of “out of place” is imposed by others (Cresswell, 1996), it is an embodied state of liminality chosen by explorers in an effort to shift the range of acceptable engagement with the environment.

While the practice clearly taps into themes of post-humanity and immateriality through the type of ruin exploration described in chapter 3, it is impossible to ignore the primal ways in which the body feeds into those imaginaries. Urban exploration, while it can clearly be seen as embracing a form of “thing materialism” (following Bennett 2004, 2010) in its rejection of identifying solely with human narratives and its passion for the built environment and architecture, is also a practice of “body materialism”. Much of the existing literature in this strain, I argue, reaches too far into the power of “things” to the point of denying the agency of the provocateur in making events happen. Although urban explorers search for places with particular aesthetic qualities that lend themselves to sensory indulgence, they also trigger these surreal sensory experiences through their agency as beings asserting their free will in places where public participation is largely excluded and/or suppressed, but also contend that they go there to experience something “beyond” the everyday; to find what may even be beyond sensory explanation.



Figure 131. Site nude in the sewer, London, photo by Site

Perhaps, in terms of embodiment, the most closely linked academic studies to urban exploration are Iain Borden's work on skateboarding where he writes about learning the city through action in places (Borden, 2001), Elizabeth Straughan's ethnography of scuba diving where divers describe to her the meditative qualities of being underwater (Straughan, 2011), Stephen Seville's work on parkour where participants "play with fear" (Saville, 2008) and Sarah Cant's research with cavers where a search for danger and mystery keep them crawling through the mud week after week (Cant, 2003). Quickly touching back on chapter 2, the important connecting factor between all these studies is that each of these researchers have become a part of the culture under study, doing embodied research with their project participants, undertaking "active recreational participation... based on 'being, doing, touching and seeing, rather than just seeing'" (Cloe and Perkins, 1998: 112). In other words, it is, to a degree, beyond representation and has to be felt.



Figure 132. Impossible places, London, photo by Silent Motion

Inside the Tube network, the feeling of trains passing by at high speed, the warm wind smashing against your face as they scream through every two minutes (see video 10, *Crack the Surface*, 2:50), watching the light panel as the current switches off after the last train and then playing on the tracks, running down the tunnels of the Northern, Piccadilly and District lines, the sheer audacity of the moment, spills into everyday life in unpredictable ways. When riding the Tube past a station we have explored together, conversations cease and we stare out the window and laugh, harbouring a secret that no one in that carriage could ever guess.

The places that urban explorers go lack the textural smoothing in evidence in more worked areas of the city. In ruins, artefacts are sometimes coated with what looks like hundreds of years of grime. Finding an old bottle that is thickly layered with time dust, one can get close to it, zooming in on it with your camera lens and watching the light refract in different patterns as you shift your stance, seemingly revealing layer after layer of active life taking place behind the scene. Quietly sitting down on the creaking floor, soft pigeon cooing above you, feeling like an out of place thing - the only thing not covered in dust - the eery ceaseless scratch of a branch rubbing against a broken glass pane down the hall, the desire to inscribe oneself into the place becomes unbearable, the existential tension building until it pops. Slowly, you lick your finger and reach out, rubbing it down the side of the bottle. Slowly now. And you take all those years of history into your body, watching your salival DNA glisten in the broken sunlight, a new layer cut right into the old. These are the ways in which a body might react, but more importantly the way a body *can* react in space where one may take the time to slow or stop, pay attention and, as Drainpipe suggests, “just be” (Drainpipe, April 2011).



Figure 133. "Gary" and the author experiencing a different pace in Spillers Millennium Mills, London, photo by author and "Gary"



Figure 134. The living ruin, Spillers Millennium Mills, London, photo by author



Some authors have described the fetish for the aesthetics of decay as ruin porn (Millington, 2010, Leary, 2011). While that is certainly a vocational fetish, let me also exhort that this sense of inscription exchange, this deeply haptic placemaking process, can also be felt in sites of construction and urban infrastructure, where the infiltration of the city's innards reveals secret sound and smellscape that pulse with hidden life. Cracking a sewer lid releases a blast of hot gases and warm air that now, after dozens of sewer explorations, has its own noxious comfort, especially in the cold of winter. The satisfying clang of the lid over our heads, plunging us into darkness until somebody clicks on their headlight, is fulfilling; a place of rare safety and security in the city where the urban traffic noise is attenuated to a hum, drowned out by the sound of water flowing over glistening Victorian brick. The feeling of security is also satisfyingly ironic of course, given we have just breached urban security to gain entry and that if it were to rain suddenly, we would likely die.

*Walking single file down the drain, the swish of fishing waders resisting the rushing grey water takes on a lovely rhythm, and voices, muted by the ceaseless swishing, morph into singing and screaming, people using their voices as drones to test the spatial reverberations of the subterranean architecture. These choral drones probably float out of manhole covers into the street, causing passing dog walkers to crack a smile or panic slightly.*

*As we reach a huge overflow chamber where we all stop to take photographs, the noise of the expedition suddenly dissipates into the vast space that creates an otherworldly echo. For a while, we sit around, basking in the stillness, the sound of trickling sewer water upstream, a slow buildup of condensation on a piece of hung-up toilet paper dripping methodically nearby, the distant prospect of a rushing river of unknown depth behind a brick barrier ferrying little pieces of decomposing mixed matter to the sea further upstream. Our stomachs still quiver from the transgression of going through the lid, the fear of drowning in fast rising water during an unanticipated rainstorm leaving us tuned into everything around us. We feel something. It's so delicious to use all of our senses, the experience so pungently vivid, existentially accelerating (Field Notes, London, October 2010, see video 8, Sewer Skank and video 9 – IDM 2011).*



Figure 135. Statler near Rubix, London, photo by Silent Motion, Statler and author

However, this tactile engagement is also the point at which the urban exploration community exposes some of its strange contradictions, as we saw with the Burlington episode. In the effort to “preserve” through photography and to leave behind some “pristine” or “virgin” sensory experience for others (RomanyWG, 2010), the community seems to be trying to fit the social expectation of contemporary eco-tourism (see Straughan, 2011, Waitt and Cook, 2007). The contradiction lies in the fact that, as Patch pointed out, the practice is based upon breaking law and expectations, yet participants are shamed into submitting to a code of ethics that no individual ever necessarily agreed to, the very reason why my project participants “broke away” from the UK scene so that they could carry out their most ambitious plans. Similar to what Straughan (2011) found in the scuba diving community, with regard to not touching the aquatic environment, and Waitt and Cook (2007) found in their work with kayakers in Thailand, participants are shamed into conformity by the mob. Though it is obvious from the stories told

in chapter 4 those who define the edges and boundaries and make the greatest discoveries in the practice likely do not subscribe to the code, either in whole or in part, it remains an integral part of the package explorers publicly offer to define themselves as a community, similar to the images they produce.



Figure 136. "Virgin" assemblage or carefully staged set? *Barenquell* Brewery, Berlin, photo by author

While many scholars have pointed to the potential affordances of everyday experience, urban exploration, along with the other activities I have highlighted above, foregrounds the importance of intentionality in invoking *extraordinary* experiences where they are perceived to be lacking. Although these experiences can be located "on the beaten track" of the everyday by shifting awareness into a heightened state of sensual presentness, the range of sensual experiences available to the urban body, especially in "public" areas are regulated by "threat of violence", accused criminality or immorality from others and leads to collective "self-surveillance" and "acceptance of dominant norms" (Moss and Dyck, 2003: 67). This

inevitably leads to what Simmel (1995 referenced in Edensor 2007) refers to as a state of neurasthenia – a dulling of the senses. However, as Edensor writes,

More powerful sensations may be sought in places on the urban margins, in which a low level of surveillance promotes a rich and varied sensory experience. Such spaces may be sought precisely because they confound familiar forms of comfort and mundane sensual experience (Edensor, 2007: 230).



Figure 137. The urban margin, Schwermaschinenbau, Germany, photo by author

Edensor goes on then, using the work of Frykman, to describe the ways in which “the modernization of the body and the senses can be described as a process containing experience [and] discovery” (Frykman, 1994: 65) which “pacifies the body” (Sennett, 1994: 15, quoted in Edensor 2007: 221). However, while these liberating places on the urban margins are often made out to be different than, on the margins of, or outside the city, urban explorers demonstrate they are in fact an integral part of the urban constitution. The right to cross the boundaries into those spaces is, Statler argues, “up to each person regardless of the legalities involved”

(Statler, August 2010) and is often asserted not in opposition to normative space but in addition to it. Ninjalicious writes,

Urban exploration revives an old and long-out-of-favour legal concept called usufruct, which basically means that someone has the right to use and enjoy the property of another, provided it is not changed or damaged in any way. Back in the day, before all property on earth came under the control of corporations, usufruct was a legal privilege that could be awarded or withdrawn by the powers that were. Today, urban explorers see nothing unreasonable or disrespectful about claiming the same privilege for themselves and applying it to their utterly benign explorations of other people's property (Ninjalicious, 2005: 69-70).

Now not all these exploration are entirely benign, as I have now shown in my concerns over the potential bureaucratic chaos we caused in the secure file storage. However, in comparison to the damage done through, for instance, fistfights that arise from nights of heavy drinking around the country or, dare I say, a financial system built on speculative investment, the inconvenience caused by a few people sneaking into the sewers, tunnels, and construction sites of cities, even if a lock is replaced or alarm temporarily disabled, is negligible. Urban explorers do no more damage than, for instance, skateboarders "waxing" a curb or a street artist stencilling characters on sterile walls and the rewards, in the form of an imaginative, desirous citizenry, are well worth the trade offs if we are truly interested in cultivating creative cities.

Explorers also, like "white hat" computer hackers, assist in strengthening security by exposing the weaknesses through benign exploration, before a group with more malicious intentions does so. It is clear from the reaction of authorities I have encountered through exploration that the "problem" with what what explorers do is not that it is "illegal", it is that, in capitalist terms, it's pointless and therefore highly suspect (I will expand on this in the final chapter). However, while authorities may be confused by it, as I have clearly shown now, urban exploration

is much more a celebration than a condemnation of capital and spectacle. It is an anti-spectacle that runs alongside the main act, weaving a breathtaking double helix.



Figure 138. The beauty of the spectacle, King's Reach Tower, South London, photo by LutEx and author

Edensor, in his 2005 book *Industrial Ruins*, writes that capital investment are the catalyst for both sensibly sterile spaces of economic production and spatial fluidity (some would say forced mobility) as well as left over, forgotten and disused spaces (albeit unintentionally); places that feel like tiny time and space seizures. Both sites, Edensor writes, are the “inevitable result of capitalist development and the relentless search for profit” (Edensor, 2005b: 4). Urban explorers are openly cognisant of the role monetary investment plays in creating both new constructions and ruins and, where preceding movements connected to my notion of place hacking condemn capitalism for creating sterile space and seek to turn streets into battlefields in an effort to overthrow the dominant social order (Juris, 2010), urban explorers celebrate capitalism for its successes and failures, rejoicing

over the construction of new skyscrapers as well as the economic crises that empty them. Both construction and destruction, which Benjamin sees as intertwined forces, create spaces of alternative tactile play and embodied opportunity, open to the usufruct hack any time, any day.

The spaces on the margins, or indeed under or above the city within the margins, facilitate the urban body in achieving altered states of experience, an altered state that Silent Motion tells us “is right there in front of you, you just have to grab it” (Silent Motion, September 2011). The places of urban exploration become portals to the surreal, cut into the everyday landscape.



Figure 139. The journey into the Paris catacombs with Marc Explo and Hydra, photo by author

*Into Paris proper we walked, past highway overpasses and old railroad tracks, into a dark alley frequented by graffiti artist and underage kids drinking cheap wine, into a hole in the wall with a four foot drop behind it, and voilà, we had crossed the liminal zone of the 'known' city into a realm of illicit encounter, raw experience, playful exuberance and corporal terror. We crawled on all fours through the mud into the darkness (Field Notes, Paris, July 2009, see video 2, Paris Catacombs).*

After entering the Paris catacombs here (Garrett, 2011b), our expectations of what to expect, think and feel began to melt, dripping off of us with the sweat and blood and caked quarry mud. It seemed all we could do was act, except in those moments when we were so shocked by some sight, smell or crushing feeling we were rendered temporarily inert. We would sometimes run into other sub-urban dwellers down there, cataphiles who spend the majority of their lives below the City of Light. We also encountered groups of people hunched over single file with bobbing headlights and bottles of port, and we would nod hello as we passed, acknowledging our shared experience in this space of unregulated sensory madness. It seemed to go on endlessly, and we achieved a state of supreme disillusionment or exceptional clarity (the meld). When we left and had to reconform to social expectations the come down hit hard.

*At the end of three days in the Paris Catacombs, perhaps due to the delirious excitement that was amassed over the course of the expedition, we thought it would be a grand idea to exit via a manhole cover in central Paris at 4 a.m. After some cartographic negotiation involving deciphering hand written notes about newly welded manhole exits, we found the cover we were looking for, realizing with some trepidation that it was up a 30 meter ladder. While Hydra guarded our packs, Marc and I climbed slowly and carefully to the top of the wet ladder and began taking turns pushing up the round iron plate which seemed to have a newly welded bar underneath necessitating superhuman strength to lift it from the inside. After a few minutes of concerted effort, I panicked, and began pushing with all my strength, back against the cover, balancing on the slippery steel ladder in the darkness, the trembling beam from my headtorch shaking against the wall. Shoulder blades jammed firmly against the cover, it tilted slightly but remained wedged like a cookie too large to fit in a cup of tea. Traces of light fluttered in from the quiet street above and I could see pavement, I felt hopeful. Then a car drove by. No it was a van. A white van. And it stopped. And then reversed.*



*Seconds later, torches were beaming through the open crack in the manhole, voices yelling unintelligible commands and inquiries in French, fielded by an exhausted Marc below me on the ladder who assured them we were not terrorists and yes, we needed help getting out. It took four police to open the manhole cover. I emerged first, being at the top of the ladder, and was sat in the police van I had seen from our subterranean prison, too tired and overjoyed to breath fresh, open air to care that I was in police custody. A female officer, assigned to guard me I guess, looked me up and down and only now did I realize that I was still wearing hip waders, my headtorch still shining, wrapped around a greasy mop of hair that had not been washed in 3 days, smelling of whiskey and sweat and coated in quarry mud from head to toe. I could tell that her first instinct was to assume I was homeless or a vagrant living beneath the city, but the obviously expensive video camera setup strapped around my neck was confusing the issue. Was her next guess that I was a geographer doing fieldwork? Not likely I suppose (Field Notes, Paris Catacombs, July 2009).*



Figure 140. Marc Explo and the author after being caught exiting a manhole in Paris, photo by Hydra

While in the quarries, we found ourselves in a negative space, a spatial gap that exists because earth matter has been excavated to build something else entirely. In architecture and urban planning this is sometimes referred to as space left over after planning or SLOAP (Maruani and Amit-Cohen, 2007). While in some writing,

like Iain Borden's research on skateboarding (Borden, 2001), we find that those negative spaces are used for various urban subversions, being largely ignored space, we rarely imagine SLOAP as vast as the urban underground in Paris. As Marc Explo told me while we were wandering the 180 kilometres of subterranean galleries and chambers "if you want to know how big the quarries are, just look at all the buildings made of limestone in Paris. Then you understand the immensity of what we're in" (Marc Explo, April 2009).



Figure 141. A gathering in the illegal underground cinema, Paris, photo by author<sup>47</sup>

### **The sensory surreal**

That immensity goes beyond a spatial metaphor, it is also a feeling. While I argue urban exploration is a deeply embodied practice, I also want to make it clear that much of what urban explorers are assaying is that which verges on the indescribable, the sensory surreal. In short, embodiment here is as much about

<sup>47</sup> <http://www.guardian.co.uk/world/2004/sep/08/filmnews.france> (accessed 10th October 2010).

emotions as it is about sensory input. Winch sees the experience of discovery during infiltrations as deeply personal where he writes,

The whole point of this activity of ours is to discover, and those noobish ideas of discovering histories is washed away with the sweat we excrete when we're discovering experiences and emotions. Nostalgia is usually a rich ingredient of those experiences we revere, be it the nostalgia for youthful play or the nostalgia of a bygone age we inexplicably aspire to. It's bollocks really, the discovery we really make is within ourselves.<sup>48</sup>

This, I argue, is also a form of embodiment, though perhaps to understand it we have to stretch ourselves into the realm of extraordinary senses to include temperature (thermoception), kinesthetics (proprioception), pain (nociception), balance (equilibrioception) or dwell where senses spill into emotions like fear. At times I have experienced what I can only describe as existential pressure on the verge of manifesting in the bowels (always evident in the Tube), a moment of incorporeal embodiment when it feels life is being tugged in impossible, or at least incomprehensible, directions. This I like to imagine as a type of slit sensillae, the sense that spiders have to detect mechanical strain in the exoskeleton, providing information on force and vibrations. Kathleen Stewart describes these moments, in a more everyday context, as atmospheric attunements, flashes when we negotiate "the kinds of agency that might or might not add up to something with [any] intensity or duration. The enigmas and oblique events and background noises that might be barely sensed and yet are compelling", attunements which might compile as little more than "qualities, rhythms, forces, relations, and movements" (Stewart, 2011: 1). These qualities are abundant in the places urban explorers inhabit where the ghosts of time await the conjuring that takes place when bodies enter places unbidden (Edensor, 2005a, DeSilvey, 2006).

Before we begin to feel that we are moving beyond the body here, that perhaps this

---

<sup>48</sup> <http://www.thewinch.net/?p=2856> (accessed 30th March 2011).

is stretching into the realm of non-representational theory, it's important to remind ourselves that the "phenomonologists saw as one of their principle tasks the discovery of essences" (Cresswell, 2004: 23). As Cresswell goes on to write, from a phenomenological perspective "place is therefore a pre-scientific fact of life – based on the way we experience the world" that encompasses all of those "feelings", "attunements" and "essences" that makes up those (extra)sensory experiences of being in the world. While the acquisition of these forms of extrasensory knowledge may require a particular attention to the senses, we are also seeking to unbind them. Here "the body 'thinks' itself solely in terms of its involuted interconnections with its 'outside', existing as an abstract network of flows of energy and information, and in which sensation operates as the 'extremity of perception'" (Massumi, 1996, quoted in Pearson, 2009: 233).

Quite simply, the body, when undertaking urban infiltration, is in a constant state of action and reaction, not dwelling but becoming (working the edge), prepared for both the necessity of bodily engagement as well as the possibility, indeed the likelihood, of confrontation with the uncanny (Lipman, 2009, Pile, 2005) even as it observes the present moment with a clarity perhaps only available at and in the "margins" of the city, though as we have seen, those margins do not necessarily imply an in/out binary. To avoid falling back on notions of what the body *is*, we must begin to imagine what the body might *become*, both in terms of action and awareness. The explorer seeks to take control of negotiating that boundary, no longer waiting to be activated but activating themselves, others and the city around them.



Figure 142. The author in the Pimlico steam tunnels, London, photo by author

It is the becoming body, reacting to and entangled with place, that defines the nature of the exploration – one must always expect the unexpected. Touching the uncanny, whether that be the popular history forgotten or the adrenaline rush of being somewhere supremely naughty, becomes highly addictive. The fact that it can be touched, though we may be told otherwise, also reinforces the fact that places are also always becoming. In the case of “Team B’s” infiltration of the abandoned City Road Tube station in London, the crew returned week after week checking the same maintenance door until, inevitably, a worker left it unlocked.



Figure 143. Activated: the LCC in King's Reach Tower, London, photo by author

The crew immediately made calls, gathered ropes, tied off and abseiled into the station, springing the London exploration scene into action as soon as the security loophole had been identified, bodies and place instantly reforming into a new configuration, in this case, an intermingling of shredding skin and Tube train brake dust at 3am. That night, London pulsed with subversiveness as the crew abseiled into London Underground and it fought back, one descent after another in a

“reciprocal interpenetration”, where things and objects (ropes, harnesses, cameras) “became materially prosthetic organs of the body, then the body too is materially an organ of its things” (Pearson, 2009: 233). Here, as Lorimer writes, following the work of John Wylie,

Sensations which might ordinarily be conceived of as ‘external’ or ‘internal’ are replaced with explanations where affect and percept ‘are neither mysterious transhuman determinants of our sensibility, nor are they simply vectors of personal psyche, emotion or intention. They produce and circulate within a non-subjective, sometimes intersubjective, relational spacing’ (Lorimer, 2007, quoting Wylie, 2005: 243).



Figure 144. Marc Explo in the St-Martin disused station, Paris, photo by author and Marc Explo

Considering the spaces that urban explorers go, many of them forbidden and subterranean, the connections between body and city become readily apparent. The underground has long been a symbolic site of hidden and uncontrollable psychic, conjectural and mythical forces (Williams, 1990). This ominous legacy affects our relationship to apparently utilitarian underground structures and activities, such as mines, tunnels and transportation networks. While the urban explorer could, in one sense, be seen to de-mythologise those spaces, there is also

certainly an element of wanting to be enraptured by them and attempting to disseminate the wonder of that feeling widely through digital media.



Figure 145. The author in a Metro line extension before tracks are laid, Paris, photo by author and Otter

Similar to wilderness backpackers, urban explorers seek to tap into the surreal in places of inhuman scale, to enter the meditative state of being in between life and death where everything, including our own embodied sovereignty, hangs in the balance, where one is suspended in rapture by a moment of such utter sensory incredulity that the only appropriate response is inarticulable, an infantile gurgle. It is a deep embodied work of bringing passion to the in between, wrapped in the sensuous pleasure of spatial liminality and embodied subversion. The double-edged reward to be found, up high and underground, is articulated in the early writing of Edmund Burke,

The passion caused by the great and sublime in nature is astonishment, and astonishment is that state of the soul in which all its motions are suspended, with some degree of horror. The mind is so entirely filled with its object that it cannot entertain any other, nor reason on that object which fills it. Astonishment is the effect of the sublime in its highest



degree; its inferior effects are admiration, reverence, and respect (Elliot, 1937: 49).

Recent work in geography around ghostly presences, what Derrida calls hauntology, also edge into frame. Thinking back to Freud's notion of the palimpsest that I mentioned in chapter 3, the appreciation for memorial stratigraphy of both material and immaterial traces, this sort of surrealist archaeology (Bey, 1985: xii), Derrida writes,

Even if it is in oneself, in the others, in the others in oneself: they are always there, spectres, even if they do not exist, even if they are no longer, even if they are not yet. They give us to rethink the 'there' as soon as we open our mouths (Derrida, 1994 1994: 11, referenced in Wylie 2007).

This is the becoming body manifesting again (Lyng, 2004), a body negotiating boundaries, revealing the strains, cracks, limits and potentials of ourselves as free beings. These spectral encounters are to be found all around us in urban environments, hibernating in ruins, tunnels, crane and train cabs waiting to be tapped and tested. While this experience is felt, mediated and attenuated perhaps, through the body, it also touches something greater than body-as-self, something more than human, something more than worldly. It is problematic to describe this as an "emotional" response, given the importance of embodied exchange in the encounter, but where emotion plays its part, it is impossible to ignore the pre-eminence of desire and fear.

### **Sociopathic metabolism**

Urban exploration has been described as a "a type of play that generates *closeness* with the city" (McRae 2008: 130). It has also been argued that children have a greater capacity, range or perhaps attunement to the world, before social conditioning begins to slowly constrict the range of perceived possibility (Jones,

2001, Aitken, 1994). Exploration of liminal space, and the patience, persistence and creative thinking that it requires to hack places in the ways I have illustrated in this thesis, multiply the possibility for affective engagement where affect is the capacity that an agent has to form specific relations to people, places and things (Buchanan, 1997). Here we can make a short leap, using the work of Kathleen Stewart (2011), to see that children are born into a world, into a body, with a vast range and potential for affective engagement. However, as the social body begins to condition the individual body, the range of affective possibility narrows according to the range of possibility accorded by the dominant society – in this case late capitalism and its insistence that affective relations be profitable and serve national and economic interest, many times at the violent expense of community and/or individual freedom.

By infiltrating the material social body, the urban body, by entering the metropolitan metabolism and jittering its internal organs, undertaking pointless subversive play in the veins and arteries of the city, we physically, psychically and playfully rearrange the affectual register, thereby rewriting fragments of the spatial code which then feed back into the social code. Each fragment is a slow seeping virus of wonder that causes the social body to go into spasms and fits (the public backlash) when viewing the effort and energy invested in what is *clearly* so pointless and yet so stunningly beautiful and infectious nonetheless. The virus unleashed, when it reveals secrets that seem so incredibly unlikely (i.e. people running through Tube tunnels), is unstoppable in inspiring symptomatic mass panic and joy, backlit affectual celebrations registered as world wide web hits on our servers in the millions and jealous vitriol in comment boxes. The interest that we receive in the practice, from writers to journalists to students to documentary

filmmakers, a relentless appetite for more, betrays the desire that urban exploration invokes, a desire for something more than the everyday that eclipses the practice to the point we are under threat of being consumed by it, McRae's spectacle appropriation in progress (McRae, 2008: 158).



Figure 146. The author acting on a desire to fear, Paris, photo by author

*Desire* is radically intransitive, not a thing in itself but that which enables us to desire (Buchanan, 1997, Buchanan and Lambert, 2011). We are both the consumers and producers of that emotional state, in the same way we might manufacture fear to increase adrenaline levels while exploring, in the same way I have manufactured the group under study to some extent. Urban exploration, while it may be viewed externally as transgressive, is rather full of moments of comprehensive engagement with social life, flashes when the “husk of alienation [is] shed” to reveal “fruits of collective activity” (Shields, 1999: 31, referenced in McRae 2008) that are fantastically playful and deliriously beautiful. Edensor writes “derelict factories are vast centres for exploration containing lengthy corridors to

run along, stairs to scamper up, windows to climb through, trap doors, pulleys and channels to negotiate” (Edensor, 2005b: 25) and recalls

Familiar sensations of childhood for me, when I dwelt in dens and woods and ostensibly off-limits derelict houses alone and with friends. The “thingness” of these objects, their material qualities and their potentialities for manual apprehension release a flood of neglected sense-making capacities (Edensor, 2007: 228).

What Edensor describes is “an enchanted notion of place which, through wonderment, imagination and participation, is in continuous composition” (Saville, 2008: 892, following Crouch, 2003, Edensor 2005b, Fenton 2005 and Thrift 2004) that may “encompass an enhanced clarity of thought, or act as a portal to new modalities of feeling” (Conradson, 2007: 34). But whether these modalities of feeling, as Conradson suggests, are actually new, is an interesting point. Alastair Bonnett contends that,

[Urban Exploration] may be about reclaiming a childhood. I think there is a real interesting thing in this whole debate about childhood and people getting older and feeling conscious that they’ve lost something or they never had something in their childhood. Because, you know, the way children are treated these days, it’s a very caged experience (Bonnett in Garrett, 2010a: 1452).

So urban exploration, like parkour, is a call to experience the world in a way which veers from what constitutes normative behaviour but also aligns more closely with childhood “as a practice that can enrich and redefine our existence, one which encourages contact, wonder and the willingness to place a hope in fear” (Saville, 2008: 909).



Figure 147. Childish behaviour: Silent Motion spinning in an office chair, Gillette factory, Hounslow, photo by author

*I had been running around all day collecting various things, tea lights, balloons, a propane tank, alcohol, snacks, and of course, a load of fireworks. Winch picked me up and we headed to King's Reach Tower (KRT), a 30-story derelict office block sitting right over the Thames. In the street we met Statler, Otter, Silent Motion and Patch. Silent Motion slipped away as we were talking and went over the hoarding in front of three disabled security cameras. Moments later, he opened the fire exit and I walked through dressed in a high visibility vest and hard hat, lugging the propane tank over one shoulder and a duffle bag full of fun in the other.*

*When we reached the 29<sup>th</sup> floor of the building, we spent hours blowing up balloons off the propane tank, lighting candles and drinking Red Stripes. By the time Marc showed up, we had assembled a few dozen people for his 29<sup>th</sup> birthday in a derelict penthouse with the most spectacular London view one could imagine. Neb had somehow lugged a sound system up 29 floors hooked it up to a car battery – how he got it in I had no idea. We danced, drank, laughed, screamed and exploded fireworks, the city below us completely oblivious to the fact we had just taken over a 30-story building for the night. Somewhere around 2am, Silent Motion and I slipped out to the park below. Borrowing some parking blocks and cones from the street, we arranged a dazzling array of exploding fireworks aimed at the 29<sup>th</sup> floor of the tower for everyone to see. When the police arrived in the park to tell us they had seen the explosion from the street, the occupiers of the KRT explorer penthouse laughed their asses off, silenced by the distance and unnoticed at street level as Silent Motion and I apologised and then*

*snuck back up the tower after the police left* (Field Notes, London, December 2010).

This LCC party in King's Reach Tower, ridiculous as it may have appeared to outsiders<sup>49</sup> was incredibly liberating – to just be childish and free for a night, to let desire reign in a Bacchian frenzy. It was a night when “freedom [became] a form of embodied awareness: a choosing to sense and, more specifically, a choosing to feel and touch an environment” in an intimate way (Lewis, 2000: 58, quoted in Saville 2008: 904-905). Many times, these events inevitably led to encounters with authorities, as it did in the park under KRT, but we also play with the fear of being “caught”, which adds another enticing layer to the embodied experience.

### **The right to fear**

It is arguable that in childhood we also experience fear more often, which, like play, can be liberating in inspiring the surreal. In Greek, there is but one word for “fear” and for “wonder” (Buchanan 2008). This bridges the physicality of an exploration with other connecting emotions, of which fear is perhaps the most powerful. In 2010, the well known and respected London urban explorer and BASE jumper Downfallen fell to his death in the mountains of Switzerland. In a piece written in his memory, a friend quoted him as writing,

I choose to live my life to a different tune of music, one which is not censored or wrapped up so much with a blanket of over regulation, Health and Safety gone mad (because these days it has), fear and blind compliance to anything you are told to do...a blanket so thick, that you no longer can hear the music. If I'm injured, you'll hear me blaming only one person...myself. It's acceptance of personal responsibility for my actions, a quality that's very much lacking in society these days.<sup>50</sup>

---

<sup>49</sup> <http://vimeo.com/17033526> (accessed 11 November 2011).

<sup>50</sup> <http://www.skyscrapernews.com/news.php?ref=2414> (accessed 10<sup>th</sup> January 2010).



Figure 148. The author doing edgework at *Landschaftepark Duisberg Nord*, Germany, photo by Winch

Many urban explorers, like Downfallen, insist on their right to do their bodies harm, to put their bodies in harm's way. Downfallen died for this belief, becoming a hero among the community and adding himself to the list with Predator, Solomon and Ninjalicious who the community has lost (not all under such tragic circumstances). The desire to do this, while it may be argued is innate in some people, is also a reaction to an urban environment in the neoliberal city which is,

Insulating our bodies from physical stimuli. [Richard] Sennett detects a pervasive fear of touch behind these developments which, by giving us "freedom from resistance," only serve to increase our passivity and diminish our capacities for empathy or meaningful engagement in public life (Howes, 2005: 3, referencing Sennett 1994: 15, also see Scott, 1998).

Subjecting our bodies to circumstances in which we experience extreme and powerful emotions and overwhelming sensory inducements is something we are rarely, if ever, offered by the modern urban environment where there is a constant feeling among many people that the city is built for others and we may look at it but we may not touch it, the spatial equivalent of the artefact in a glass case in the museum. At times that frustration manifests in violent reaction, as in the summer 2011 London riots. Whatever the politics behind the event, there was a clear joy people experienced finally being able to kick in a window and burn cars, taking what they liked from the city, huddled together with friends, sweating and fighting the police for control of their neighbourhood streets. Atrocious as it appeared to some, jubilation was in heavy abundance. There are many ways that type of euphoria can be achieved through different practices, with or without violence, but in many circumstances making the choice to engage it is seen as transgressive, whether or not practitioners themselves view it in that light.

In Saville's work with parkour participants, he writes that "the traceur is ever questing towards new and often fearful movements, many of which are predicated



on the attainment of bodily skill” where “fear can be a highly complex engagement with place, which can in some circumstances be considered more a playmate than paralysing overlord” (Saville, 2008: 893). Whereas in everyday urban life fear can be an ominous and perhaps uncontrollable force, a vague possibility of a mugging or a terrorist attack, during an exploration of a space inherently dangerous “the unfamiliar acquisition of a skilful apprehension of space is necessary for [our] own safety” (Edensor, 2007: 227). Fear, when met with existential resistance, can produce an “internal state of calm in which a person becomes more aware of their immediate embodied experience of the world and less concerned with events occurring ‘out there’” (Conradson, 2007: 33). At times, this can inspire explorers to even contrive fearful experiences in order to create a moment to “overcome”, also challenging other explorers to panic in the face of danger, testing their mettle.

*At the International Drain Meet in 2011, where over 50 explorers gathered in London to celebrate urban exploration and draining, everybody was partying in an overflow chamber under Hyde Park (see cover photo). After everyone had been drinking for some time, a drama unfolded when User Scott came in and said to everyone that he'd seen Thames Water workers walking around in the Westbourne, likely looking for us, given we had, just a few hours earlier, ferried dozens of people into three different sewer lids in Knightsbridge. The music was killed and murmurs began circulating. A forward expedition was organized by Siologen to go “investigate” and/or confront the workers. It was suggested that offering them a beer might help and Siologen was given a few. While he was gone, various theories were fielded on what might happen if workers actually did find us in here, the fear causing a mass adrenaline rush as we imagined flooding out of the drain system all at once to escape arrest. When Siologen returned, finding nothing, the party continued, the small drama dissipated (Field Notes, London, January 2011).*

In this instance at the International Drain Meet, we can't be sure whether there was a genuine concern or whether the entire scenario was fictitious. But it doesn't really matter – fear was located, utilized and transformed into adrenaline, which fed the energy of the gathering. Fear became a tool for existential liberation rather than an impetus for “self-policing”. The hesitancy that manifests

as fear to be overcome is a result not just of encounters with authority, but with the spectral, the uncanny, the unexpected and various hostile forces whilst exploring.



Figure 149. Statler at the International Drain Meet, London, photo by LutEx

Using fear in this way... experiences of fear are both limiting and liberating. Because we live in a cultural climate in which the normative message is to be safe and to minimize fear (O'Malley and Mugford, 1995)... edgeworkers and other social outsiders, find political currency in actively seeking out risks to “overcome their victimhood, and become social agents, agents of cultural production” (Pedrazzi and Desrosiers-Lauzon, 2011). In this, they are developing valued social identities as fearless, heroic and powerful, thereby offering a political critique of the structural limitations of their everyday lives (Olstead, 2011: 7).

The possibility of getting caught is always a great catalyst for heightening the experience of an exploration and is, of course, always connected to the embodied experience of being in places, a testing of the limits of, for instance, how quiet the body can be while jumping over a chain link fence, a type of skill rarely, if ever, cultivated in everyday life. As Marc told me while exploring once at dusk,

You have to think about the trade offs between sight and sound when sneaking around. In the night, you may be less visible, but then you're going to be more likely to step on glass and loud things while sneaking around, or shine your torch through a window and get busted. In the day, you can be quieter but you also have to be more sneaky, if you're seen, it's game over (Marc Explo, September 2010).

The experience of testing the boundaries of the body's capacity for "being sneaky" is an "embodied grounding of affective potential" (Saville 2008: 894) that allows the explorer to play with places and make them personal in the process. Although fear, or any other strong emotion, is something that can be imposed by external forces, and in those moments we may choose to surrender to that fear, we may also take the agency of initiative to invite playful surrender or resistance to fear. In the production of fear, the agency of the human subject is undeniable, especially where the catalyst for feeling is a confrontation over control with those wild unregulated entities. By meeting them, "the impossible recedes, like a horizon, never sets, like a sun. But as it recedes other regions of the world appear" (Massumi, 1997: 761), new sites to hack in our search for the becoming body meld. In confronting that fear, in discovering new worlds, we also begin to unravel the mysteries of the things that connect us all in the city.

### **The meld: urban bodies**

"The city is made and made over into the simulacrum of the body, and the body, in its turn, is transformed, 'citified', urbanized..."

– Elizabeth Grosz (1998: 31)

I have shown that urban exploration is a search for proximal tactile experiences located at the porous, pulsing intersections of bodies and places in (re)discovered locations. In creating relationships of meaning in off-limits locals, urban explorers understand that meaning can't be purely conceptual nor purely spatial, that "meaning is generated not by either subject or object but in the space between

them” (Hetherington, 2003: 1938). And what better place to cultivate those deep in-between meanings than in in-between urban spaces?



Figure 150. The author experiencing the meld; the body in the city and city in the body, the River Westbourne, London, photo by author

While I hope it is now clear that urban exploration is a deeply embodied practice, including those aspects of embodiment that tug on emotions and the non-representational, I would also like to consider the connections between the body, the mind and the city to push forward my notion of the place hack opening the becoming body to create meld moments. As I will demonstrate, the practice complicates the body in place/body out of place binary (Cresswell, 1996) to create moments of dissolved embodiment where the place hacker enters the system and melds into the liminal matrix. Here, “the dominating body is dissolved – consumed by its own capacity for chaos and transformed into a becoming body” (Lyng, 2004: 370) and the city itself “puts the moves on us... The places where we are located inhabit us as subject positions” (Hetherington, 2003: 1943). In this section, I will also return to the use of photographic technology in the practice, again, not as a

mediating device threatening embodied subjectivity, but as a technological bodily appendage that further collapses binary oppositions, following Jean Rouch (2003: 99, 184).

### A case study in draining

“If we take London, for example, there is a great story to be told about the unmapped and untraceable water supply and sewerage networks that dwell underneath the city...”

– Kaika and Swyngedouw (2000: 136)

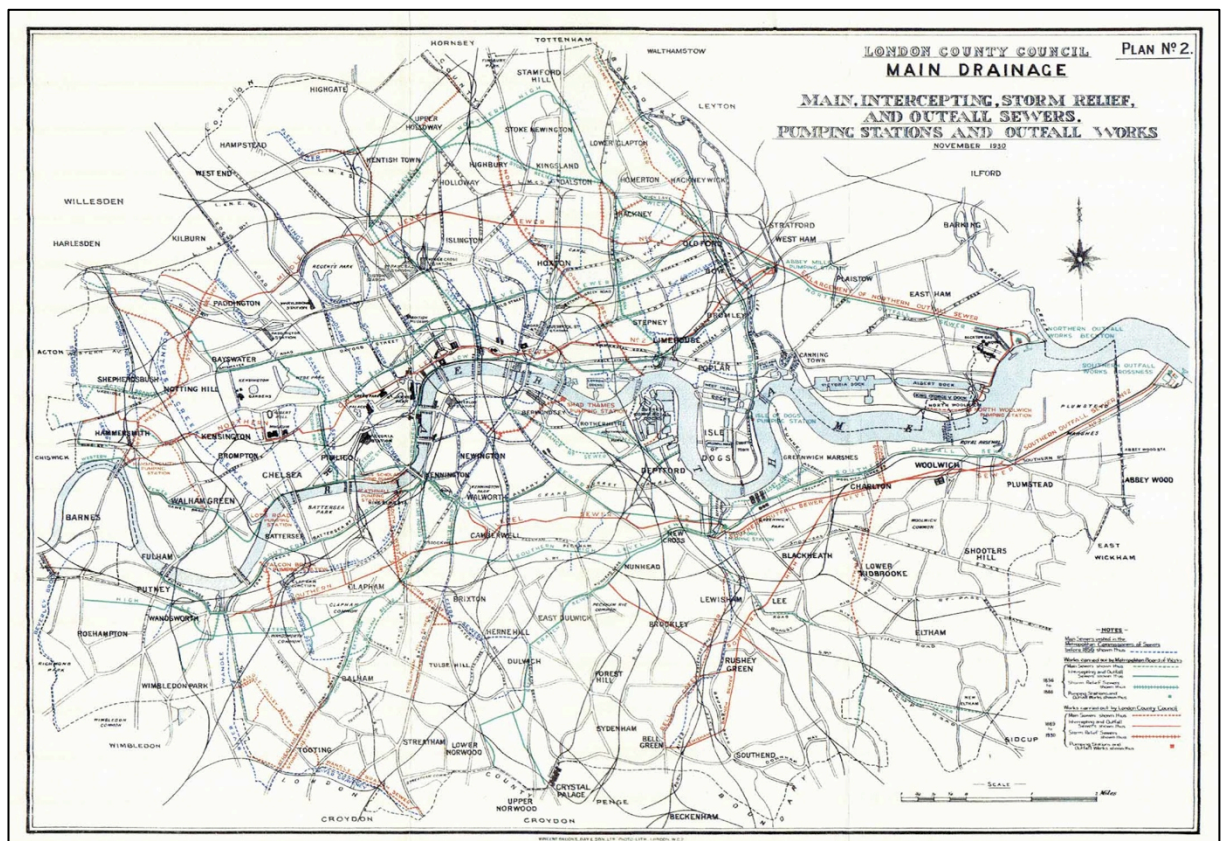

Figure 151. 1930 London drain map used by the LCC, image via <http://www.sewerhistory.org>

As the LCC continued our assault on the urban security of London, we also often travelled internationally to meet with other explorers now that we had gained international recognition for our work. We increasingly found ourselves inside various cities, including Paris. In December 2010, myself, Winch, Otter and Marc delved into the Paris sewer system, chasing the ghost of the Parisian eccentric and urban photographer Félix Nadar, using the work of urban geographer Matthew Gandy as a roadmap for exploration of the system (Gandy, 1999). Félix Nadar was

a photographer who, at the time he was working, sought to make a photographic record of what many saw as modernity's finest achievement – the mechanisation of the urban metabolism in the form of the Paris Sewers.

The radical infrastructural transformations between 1850 and 1870 that Nadar was photographing were provoked by a massive population spike that led to a cholera epidemic, flanked by typhus, requiring a radical infrastructural solution. In Paris, the construction of the sewers that still exist were that solution; a utopic promise to urban dwellers plagued by disease in the 19<sup>th</sup> century. The urban infrastructure that delivered salvation thus became popular tourist destinations, including Abbey Mills and Crossness Pumping Station in London as well as the Paris sewers, where boat rides were offered down the stream of the combined system.

For contemporary urban explorers in London and Paris, the period when Nadar was doing photographic work in subterranean Paris is a crucial one. During that time, both of the drain networks were built to the rough configuration in which they remain, the work of urban planners and engineers like Joseph Bazalgette and Baron Haussmann. Nadar was fascinated by these changes, as well as all things subterranean, and spent a great deal of time photographing the Paris catacombs and sewers, leading many urban explorers to think of Nadar, and his contemporary John Hollingshead in London (Hollingshead, 2009 [1862]), as the first “drainers” (The name Félix Nadar was even a pseudonym!).



Figure 152. Victorians in Abbey Mills Pumping Station, London, 1868, image via <http://ragpickinghistory.co.uk>



Figure 153. Explorers in Abbey Mills pumping station, London, 2011, photo by author

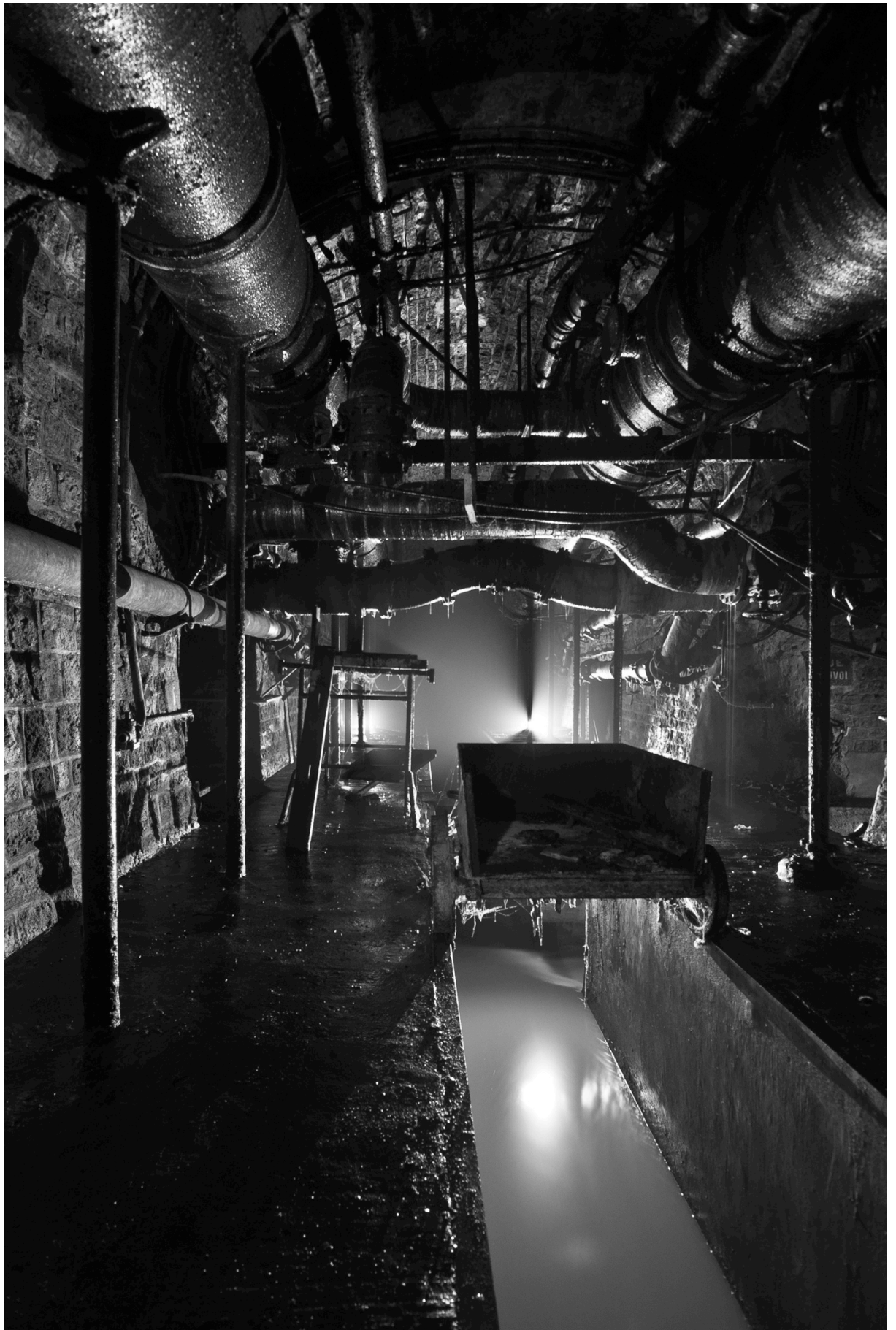

Figure 154. The Paris sewers, photo by Otter, Winch and author



These early construction projects impressed a public who eagerly awaited technological emancipation and Hollingshead and Nadar were there to render those constructions transparent. However, Kaika and Swyngedouw point out that as people found themselves working even longer hours under increasingly monotonous conditions, a realisation dawned that these technologies had not delivered on their promises of liberation from class oppression but rather simply relegated more of their time to work. As a result, “the mess, the dirt, the underbelly of the city, both socially and environmentally, became invisible and banned from everyday consciousness” (Kaika and Swyngedouw, 2000: 135) and “underground sewerage pipes were not revisited” (Kaika and Swyngedouw, 2000: 134) in an effort to promote yet a new promise – the networks were no longer to be revered but ignored. In the language of the “new” promise for freedom from suffering, in the machine-slick language of architects like le Corbusier, “the perfect house became individual, clear, pure, functional and safe for the inhabitant, protected from the anomie and the antinomies of the outside and the underneath, the urban” (Kaika and Swyngedouw, 2000: 134).

It was no coincidence then that these systems were buried and forgotten. Due to long-perceived associations of subterranean space as unhealthy, unclean and evil, citizens held a multitude of beliefs that “engendered an obsession with fissures, interstices and imperfect joinings [for] these are the sites of contact through which mephitic exhalations filter out” (Corbin 1986: 26 referenced in Pyke, 2005: 229). The construction of these systems, as well as the waning interest in seeing them, led to the mysterious mythologisation of urban infrastructures, viewed only occasionally where seams fractured. It wasn’t until the early 21<sup>st</sup> century that urban explorers began systematically re-exposing these hidden urban networks,

showing the world what had been disappeared underground materially and symbolically. This is not an insignificant legacy.



Figure 155. Furtle inside the Colossus of the South, Brighton, photo by author and Furtle

Historically, these imperfect joinings between the city and the subterranean, when cracked open, were seen as analogous to a flesh wound, the broken skin now ripe for bidirectional infection, the urban body as host, the city's innards a ripe contamination zone. John Hollingshead, whilst traversing London's sewer system in 1861, noted that "a piece of ordinary rust or of moist red brick is soon pictured as a trace of blood" (Hollingshead, 2009 [1862]: 4). Entry into subterreanea soon became acceptable only for rats and criminals, those who were already seen as polluted bodies, depicted in countless books and films such as *Les Misérables* (Hugo, 1987) and *The Third Man* (Reed, 1949).

Yet we see the contemporary resurgence in the interest in these pulsing interstitial nodes through the words of Canadian urban explorer Michael Cook, though unlike the Victorians, he sees these cracks as opportunities rather than infection zones.

Cook writes,

The built environment of the city has always been incomplete, by omission and necessity, and will remain so. Despite the visions of futurists, the work of our planners and cement-layers thankfully remains a fractured and discontinuous whole, an urban field riven with internal margins, pockmarked by decay, underlaid with secret waterways. Stepping outside our prearranged traffic patterns and established destinations, we find a city laced with liminality... We find a thousand vanishing points, each unique, each alive... (Cook quoted in Manaugh, 2009: 63).

Cook's writing hints at the possibility that the structure of the city doesn't just "seem" alive, it *is* alive. If architecture and the built environment is a reflection of what we know, then it comes as no surprise that we have constructed our buildings, our cities, as corporal simulacra. Descending into Cook's "vanishing points", we enter the city's bloodstream and begin to witness our effects on the urban metabolism, melding body with machine. Mr. Hollingshead, our Victorian London drainer, had such an encounter while venturing into a drain under a house he once owned in London's West End. He wrote that he "felt as if the power had been granted me of opening a trap-door in my chest, to look upon the long-hidden machinery of my mysterious body" (Hollingshead, 2009 [1862]: 62). The connection between his own body and the drain that contained the contents of his body is no fortuitous correlation. In the Tyburn River we stood underneath Buckingham Palace. Siologen, turning to look at the other drainers on the expedition, said "boys, you may never have tea with the queen of England but you can now say you've stood in her shit" (Siologen, January 2011). Sewers are the great class leveller. As Kaika and Swyngedouw write, these radical urban reconfigurations were packaged with promises by urban planners that an

egalitarian human liberation awaited us behind each public works project, bringing order, health, safety and freedom from excessive labour.

The disempowered were bound to finally enter the paradise of technological freedom if only they would be patient and hardworking enough to serve the god of technology for an undefined and indefinable length of time. Freedom was promised at each turn of the corner, to be relentlessly frustrated again by the next promise (Kaika and Swyngedouw, 2000: 125).



Figure 156. The author and Marc Explo at "Unibrow", London, photo by author and Marc Explo

There are two ironies here in regard to liberating technologies. The first is that where Nadar, at the tail end of the 19<sup>th</sup> century, was taking photographs at 18-minute exposures, technological advancements in photography allow us to now take sharper, more detailed photos in 20-30 seconds of the same sewer network. So it is essentially yet another advancement in technology allowing us to, once again, make those networks visible, along, of course, with the desire to do so. The camera also acts as a prop lending legitimacy to the presence of the explorer, under terms understandable to police, property owners and security guards (oh

me, I'm just an artist) as much as it acts as a recording device. As a strategy, the camera as appendage to the urban body is a "double game which consists [of] acting in conformity with one's interests while giving the appearance of playing by the rules" (Bourdieu and Lamaison, 1986: 113). The camera, whether still or video, is another aspect of the meld taking place, between bodies and space where we enter each other. Where contemporary consumerism continues to offer the same fictitious technological liberation seen in the 19<sup>th</sup> century (life will finally be easy once you buy the new MacBook!), as with the city, we appropriate that technology, hack it, rework it and rebuilt it in our image, democratising through the meld.

Secondly, and maybe slightly more bizarrely, is the fact that, as the engineering wonders of the 19<sup>th</sup> century are slowly being revealed by urban explorers in London, Paris, Moscow, Milan, Minneapolis, New York, Stockholm and Tokyo, a new type of fetishism is emerging within the urban exploration "scene" for those urban planners and engineers who built these systems. In London for instance, the respect for the work of Sir Joseph Bazalgette, who designed the beautiful self-cleaning egg-shaped brick sewer networks, has led to the creation of a Facebook page for him,<sup>51</sup> and multiple explorers adding him as their "father". Before expeditions into the sewers, Bazalgette will many times "bless" the expedition on Facebook and he is often invoked while in the networks, toasted with champagne at each drain party as "J-Bizzle" (Video 9 - *IDM 2011*, 3:25). In both cases, continued technological development allows for a changing urban relationship, though, importantly, those technologies are perhaps being used in way not intended by their developers, they have been hacked.

---

<sup>51</sup> <http://www.facebook.com/#!/sewerfresh> (accessed 3rd February 2011).

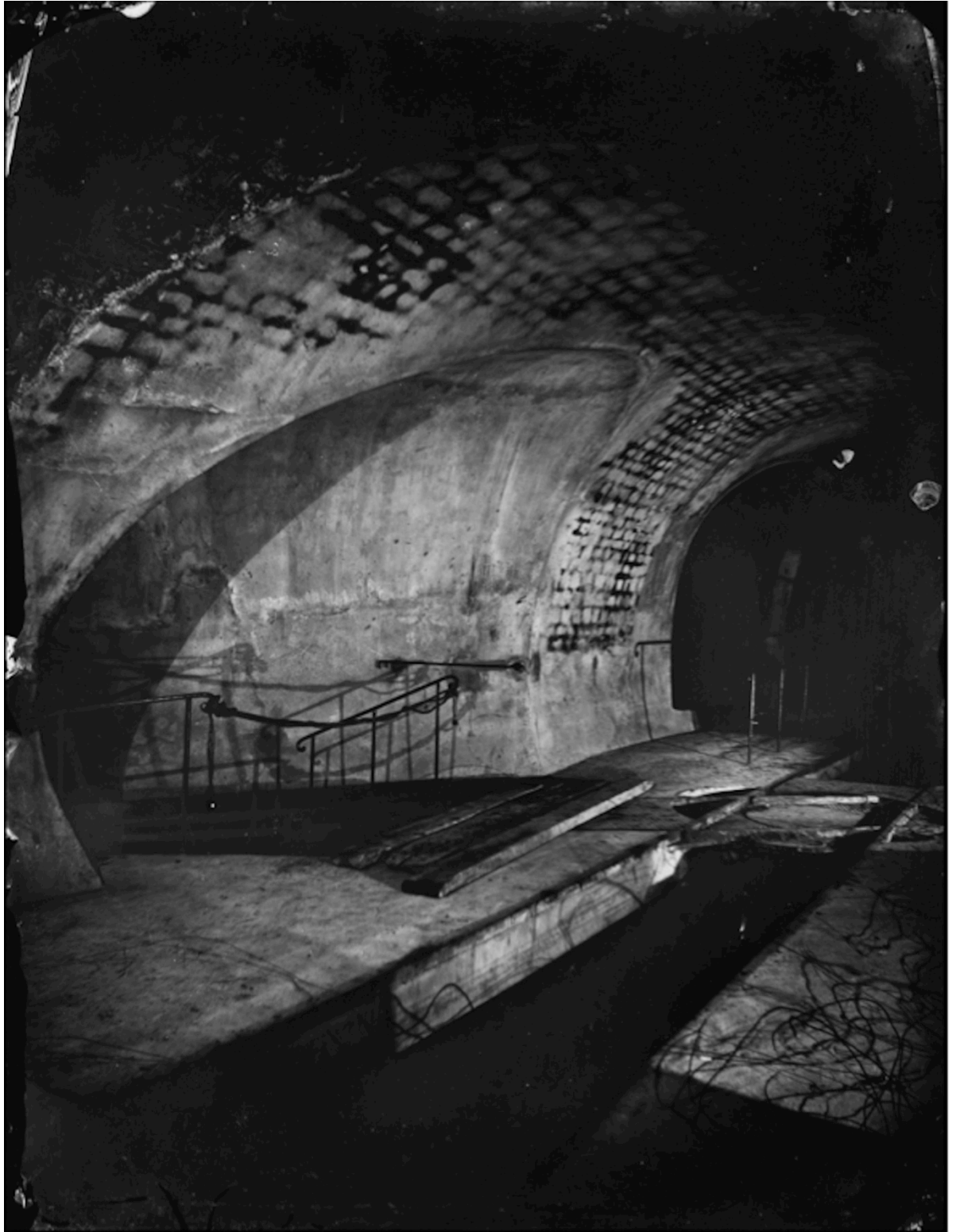

Figure 157. An 1864–65 photo by Félix Nadar of the Paris Sewers, image via (Gandy, 1999)



Figure 158. A 2011 LCC reshoot of Nadar's 1865 photo, Paris, photo by Otter, Marc Explo and the author

If “cybernetics is, as Norbert Wiener declared, the revision of information through the exchange of information” (Sennett, 2008: np) and the moments of encounter between our bodies and the urban infrastructure alter either physical structure or mental conceptions where “...the body (as a cultural product) transforms, reinscribes the urban landscape according to its changing (demographic, economic, and psychological) needs, extending the limits of the city, the suburban” (Grosz, 1998: 35), then Matthew Gandy is right to assert that the “emphasis of the cyborg on the material interface between the body and the city is perhaps most strikingly manifested in the physical infrastructure that links the human body to vast technological networks” (Gandy, 2005: 28).

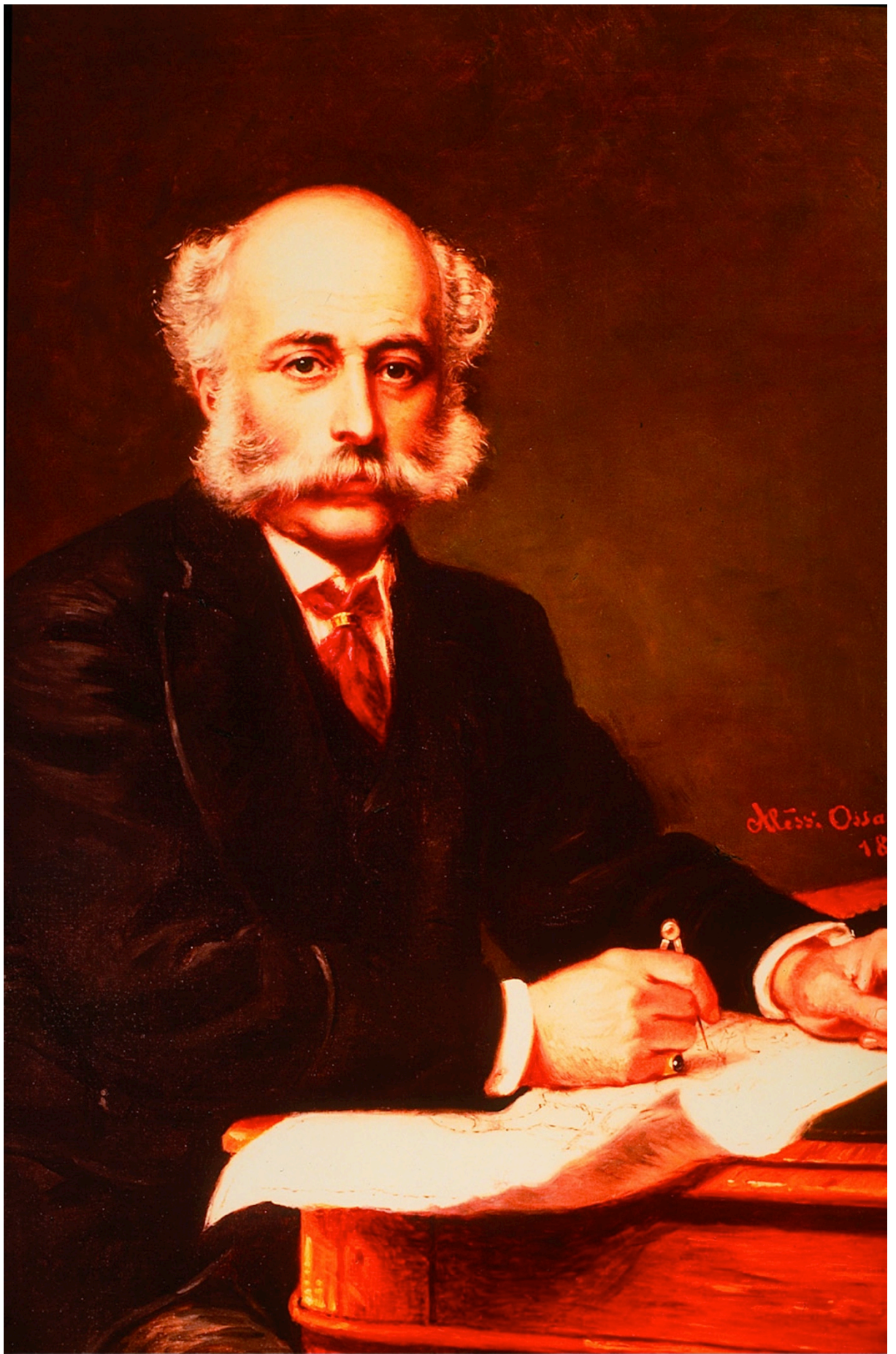

Figure 159. The father of London draining, Sir Joseph Bazalgette, image via [www.thameswater.co.uk](http://www.thameswater.co.uk)





Figure 160. The author hacking Bazalgette's hidden legacy, the River Westbourne, London, photo by author

Returning to chapter 1, where I encouraged a broader conception of the urban, once again here we see that urban exploration melds boundaries between nature and culture where “*wildness* (as opposed to wilderness) can be found anywhere; in the seemingly tame fields and woodlots of Massachusetts, in the cracks of a Manhattan sidewalk, even in the cells of our own bodies” (Cronon, 1995: 89). Again, looking to Bourdieu, this awareness challenges the social conditioning “inscribed in the body of the biological individual” (Cresswell 1999: 177 quoting Bourdieu and Lamaison, 1986). According to the work of Kaika and Swyngedouw, by revealing the hidden infrastructure of the city, we challenge the modern propensity to “fetishise” these hidden infrastructural networks (Kaika and Swyngedouw, 2000). Or maybe, in light of our elevation of particular urban planners as sort of urban exploration deities, we fetishise them in new ways, hopefully more transparently and democratically through the meld that pays reverence to their communal contributions.

Returning to our central notion of place hacking, hacking a system, be it virtual or biological, natural or cultural, will inevitably result in the hack affecting the delivering agent as well as the intended recipient system. This is how cities and systems become living, become animated. As David Pinder writes, “exploring ‘the meaning of living in a city’ at this time *is* crucial politically” (Pinder, 2005a: 399, original emphasis). At the heart of this search for differential place is a call for urban dwellers to become actors rather than spectators, to affect change rather than simply witness it (Dickens, 2008a: 27). This is the point at which urban exploration is undeniably political and the hackers themselves deeply vulnerable when working the edge. The explorer, whilst hacking the system, must also open

themselves to danger, peril and possible confrontation with authority. Exploration is always a complicated exchange, a surefire shakeup.

Sewers contain a steady stream of biological packets, full of data connecting nodes, throbbing veins, arterial chambers. The data bloodstream, like light-driven information packets, connect cyborgs, “hybrid creature[s], composed of organism and machine” (Haraway, 1991: 1). Beyond the designation of the cyborganism, its defining characteristic being a propensity to slip the net of “a world structured by boundaries and enclosures to a world dominated, at every scale, by connections, networks, and flows” (Mitchell, 2003 quoted in Gandy 2005: 32), is a possibility for transplantation, a symbiotic bilateral exchange of potentiality. Here, “the boundaries between the organic and the inorganic, blurred by cybernetic and biotechnologies, seem less sharp; the body, itself invaded and re-shaped by technology, invades and permeates the space outside, even as this space takes on dimensions that themselves confuse the inner and the outer, visually, mentally and physically” (Vidler, 1990: 37, quoted in Gandy 2005: 28) where “‘thought-as-imagination’ departs from the actual, dips into the fractal abyss, then actualizes something new” (Massumi, 1992: 101). What is it that is new here you ask? Well nothing more than an animation of the inanimate, a tangible hauntology, an acknowledgement that building forms spring out of historical contingencies – but, given enough time, they may create their own form of subjectivity (Vanderbilt, 2002), aided by our own technological appendages through the meld urban explorers invoke by opening interstices. Drains are material manifestations of our dreams (including nightmares) but also regulators of our physical potentiality as protectors of modern human existence, the physical flow of our very being.

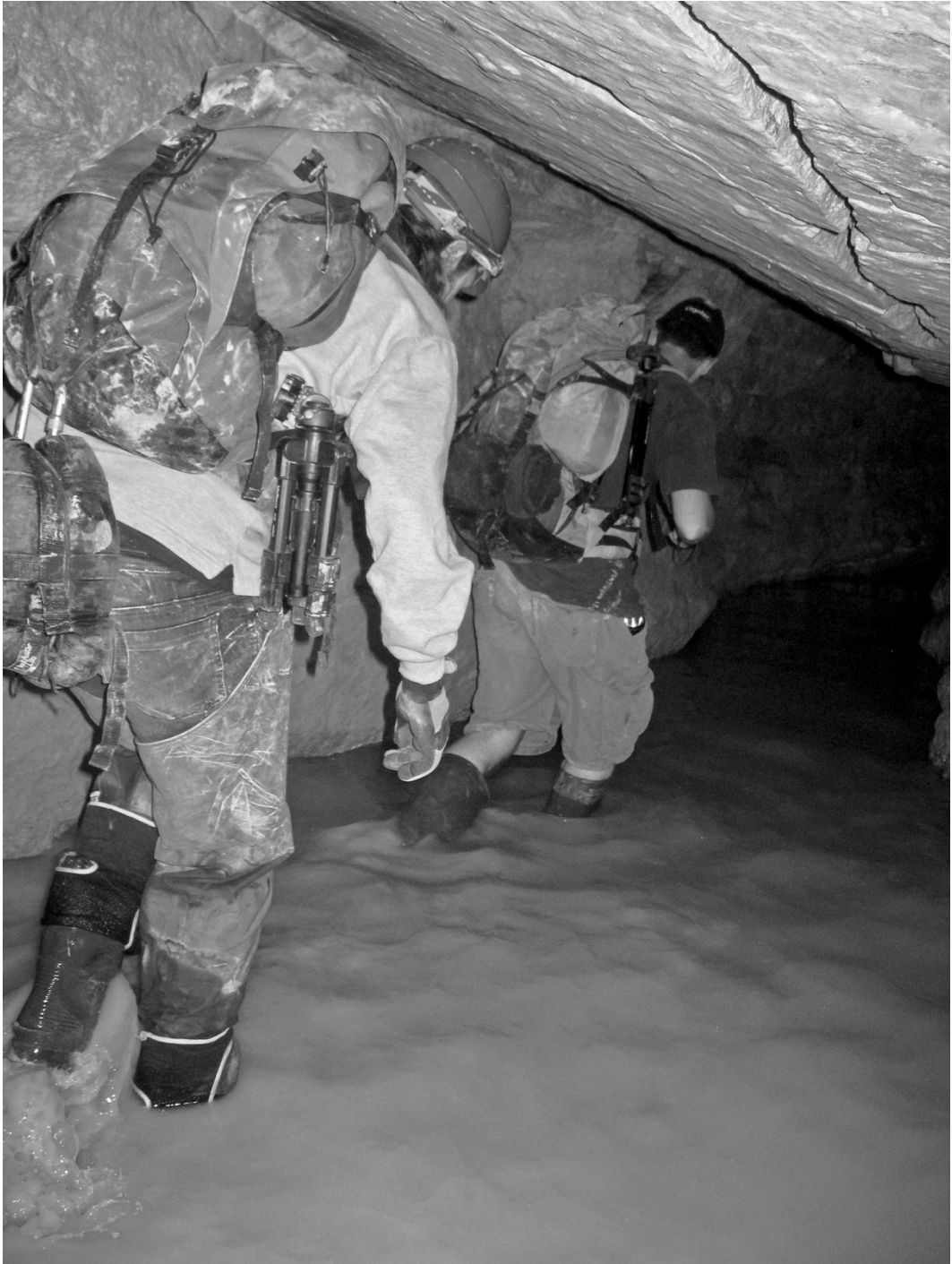

Figure 161. Biological packets, Hydra and Marc Explo, quarries of Paris, photo by author

Let us again reinforce the role of embodiment here, (under)grounding the theory. Referenced in each photo we snap are moments of not just conceptual but actual encounters that take place between urban bodies and urban infrastructures, leading to the designation of urban infrastructure *as* urban body. The result of those bodily encounters is the construction of those webs, flows, and exchanges that create communities, ideas and cyborganisms, new junctions of awareness and

possibility that stir up the whole mess, jumping over the 3<sup>rd</sup> rail after midnight and spending hours trying to get a door open with a putty knife only to find it's an empty closet. The urban explorers Deyo and Leibowitz write that "our cities have become so complex, so overwrought with layer after layer of complexity, that there is really no one person who understands how all the layers work together" (Deyo and Leibowitz 2003: 153) but that while exploring, "in the diamond clarity of fear we find the difference between speculations and experience, between philosophy and science. It's the difference between reading about the George Washington Bridge and climbing it" (Deyo and Leibowitz 2003: 211). The urban explorer, after a deep, long and intimate association with the hidden features of the city, can begin making connections between places, connect whole networks and actually reconfiguring conceptions of connections.



Figure 162. Crowding the edge of fear, Mountrouge, photo by author

Whether through the physical acts of observing and infiltrating a site, considering the lives of people who formerly occupied a space or embracing the physical sensations and emotions that one can experience in urban space, urban explorers' actions seem to counter some of the alienation of contemporary life in which vital infrastructure is hidden and denied (McRae, 2008: 96).

The actual hand-wrought work of constructing and deconstructing that fabric reveals a physicality conjoined with virtuality that is "anarchic [in it's] non-identical proliferation" (Luckhurst, 1997: 128, quoted in Gandy 2005: 30) and infectious in its resonance, where the everyday urban inhabitant can once again enable themselves to embed personal investment into those infrastructural networks and marginalised spaces, inscribing places through place hacking. The city is a reflection then not only of the physical body but of the sprawl and limitations of human consciousness and technical ability, a potential now augmented by the machines we have created, to be ingested and spun into new forms within our lifetimes, some inconceivable to us now. Urban infrastructure, although restricted by capital investment and spatial constraints, is also constrained and fortified by a human imagination of the deepest chaotic order, it's operation and moments of rupture as fragmented as urbanity itself.

Elizabeth Grosz argued, in 1996, that computers would change the way the city was structured as we built infrastructural systems not modelled upon machinery but upon virtual systems. However, were not both mechanical functions (compare the piston and valves of the heart) and cybernetic circuitry (the CPU as brain) both modelled on the body? Does not the evolution of those artificial bodies influence our biological bodies (for instance, consider the effect of indoor plumbing on the body)? Does the conjunction of those bodies and spaces, industrial machines as appendages, computer hardware as corporal augmentation, not create new hybrid bodies which will influence the infrastructure of cities? Will those imperfect

joinings that the Victorians feared infect and augment through their mephetic exhalation as promised? If Grosz is right, then the body's limbs and organs will become interchangeable parts with the computer and with the technologicalization of production (Grosz, 1998: 36). With this optimism, we may "instead of demonizing technologies assess their promise and those of new bodily configurations [afforded] by them in terms of the extent to which they promote and preserve the space of differentiation that makes our corporeal exchanges possible" (Weiss, 1999: 6 quoted in Whatmore 2002).

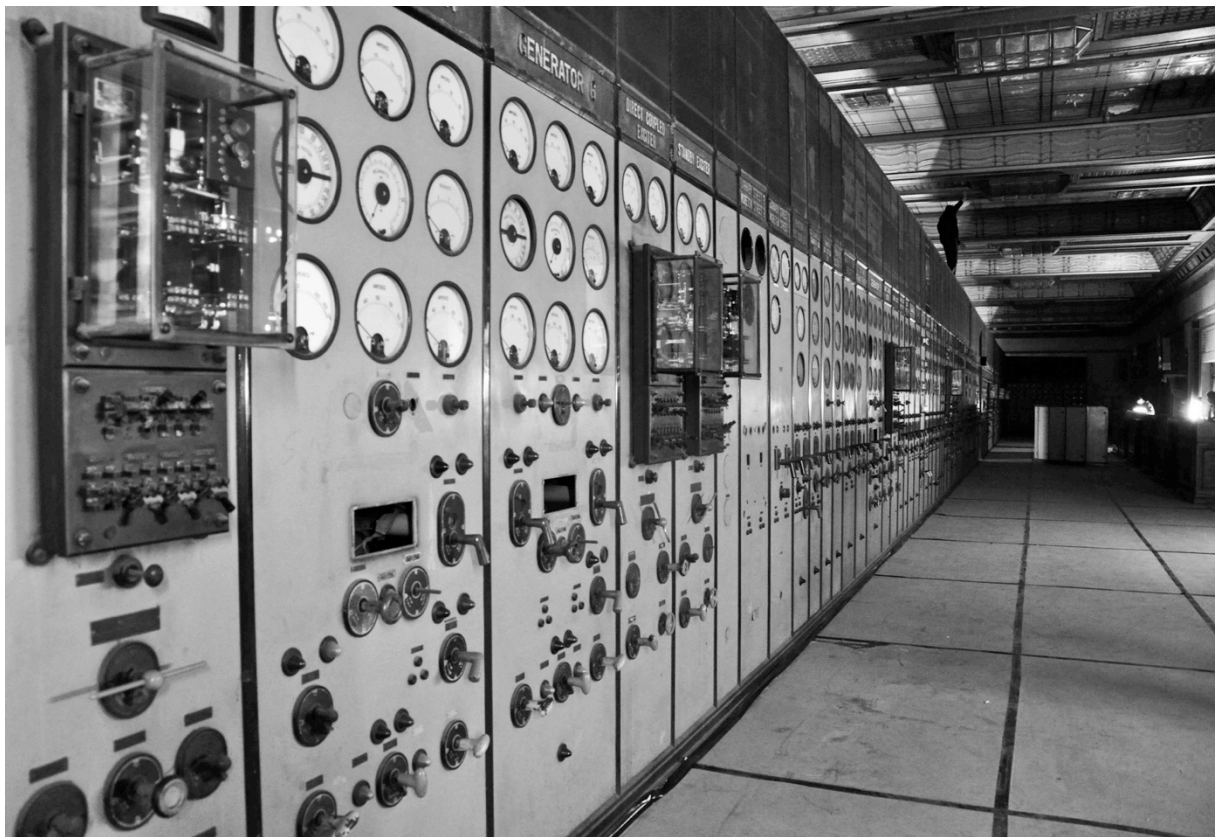

Figure 163. Outmoded infrastructure, useless organ, Control Room A, Battersea Power Station, London, photo by author

Urban explorers operate at the vanguard of the exchange, cracking open the city and exposing the joinings, interstices and points of rupture, killing themselves in the process through the necessary exposure to urban toxicity and celebrating the monstrosities of capital that are accelerating our relationships and potentialities, taking down the earth with us. Again, turning to Edensor,

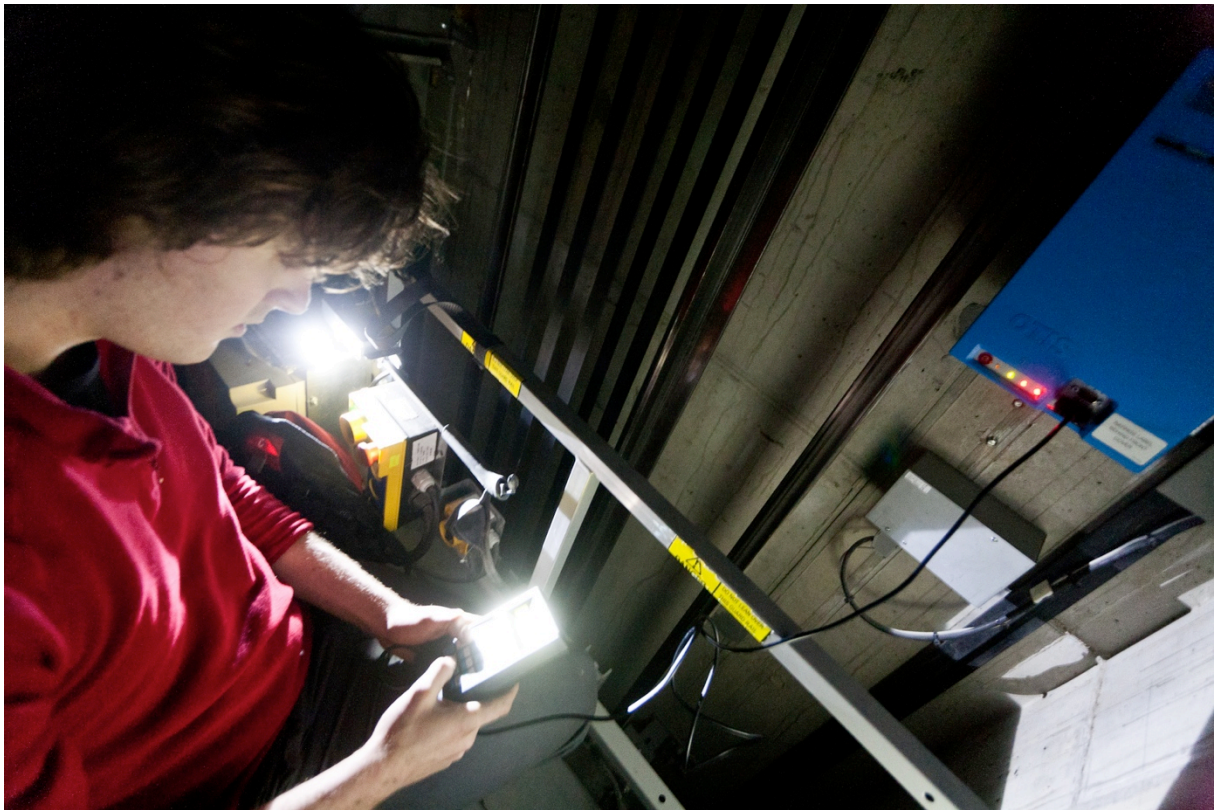

Figure 164. User Scott electronically hacking lift controls, photo by Silent Motion

Unable to insulate itself against these material intrusions, the body is rendered porous, open to the impacts of matter, is a “threshold or passage” characterized by “multiple surfaces open to other surfaces” through which “strange substances” are able “to cross the subject’s own boundaries” (Edensor 2007 referencing Fullagar, 2001: 179)

The quarries of Paris are perhaps the best Western example of the meld to be had if we continue along the path urban explorers are cutting. The quarries (catacombs) are a place where humanity has become intricately interwoven into the informal subterranean urban matrix. Paris culture would suffer a grave setback with loss of access to these spaces (not that such a thing could ever happen, they are far too vast). A co-addictive symbiotic relationship has been built over nine centuries where the populace continually hacked the closed system open again and again, leading to a consistent rediscovery of stratigraphic memorialisation and renewal that is now layered so thick with history and culture you can taste it in the soil; a desire-packed midden that stains the tongue. The catacombs are proof that just as virtual social systems can be maintained by the multitude, so can physical



space (Shea, 2011, Garrett, 2011b). The symbioses is even more profound in places like India where infrastructural space *is* living space (see Gandy, 2008), in Poland where we saw people colonizing abandoned military ruins or in Cambodia where people are living in graves (Kunthea, 2011). These places have lessons to offer the neoliberal city.



Figure 165. Marc Explo meditating, quarries of Paris, photo by Silent Motion and author

The visual, aural, sensual representations created on explorations and temporary urban residencies created in closed places create new emotional caches which can be tapped into for myth-making practices, practical applications such as sabotage in the event of authoritarian lockdown, colonised as temporary free space, including illicit party venues, or utilized as secure shelter. Increasingly, simple imaginative stimuli that reterritorialise those spaces with potential feeds not only physical constructions but imaginations. As a result, the virtual and physical aspects of urban exploration become increasingly inseparable as one network depends on the other. As I have shown throughout this thesis, urban exploration, despite its weavings into the mythologies of the sublime, is not an escape from nor a transcendence of the physical, but a challenge to the very boundaries of deeply embodied substance dualisms (Curti, 2008: 95).



Figure 166. The author lying in the bones of the dead, quarries of Paris, photo by author

Urban exploration stimulates an awareness that the city is more like a sponge than a solid mass of paved streets and architecture, more like a body than a machine. Cities are spikes and sinkholes; the surface is porous. Relocated conductive material urban fabric facilitates emotional and sensory flow, the bloodstream becoming a conduit for sublime affective registers in infinite doses. Overdose always being a possibility, we teeter on the brink, doing our edgework, which pushes the boundaries in impossible directions, creating delicious psychological architecture. We come back again and again to the cities we love, our tolerance for exposure to the pain of the meld growing each time, our possibility for transcendence of what is *offered* growing with each ascent and descent *taken*.

But what of the opposite exchange on the symbiosis? Returning to our colleague Félix Nadar – how did his photographs influence the function, form and representations of that Parisian bloodstream? How do the technological

accelerations that allow myself, Winch, Otter, Marc Explo and countless other explorers to recreate Nadar's work and spin replicative experiential simulacra, in distinct imbricating temporal iterations, begin to mutate those systems? Perhaps this is where the accusations of urban exploration being primarily a spectator sport (High and Lewis, 2007, Bennett, 2011) fall embarrassingly flat. Urban exploration can never be purely representational or apolitical. The work of the London explorers, just like those drainers of 150 years ago, opened closed systems. Urban explorers reveal the framework and recode the urban landscape daily with every scaffolding scaled and every alarm disarmed. Drainers reveal not only the cracks and gaps that exist through the representations they produce but expand those cracks and gaps through repeated exploitation and exploration. Urban exploration, training, craning and draining realises potentials for "cyborgian conceptions of the city to emphasize the continuing political salience of the public realm" (Gandy, 2005: 41).

Predator's call for "public access to public works" (Predator, ND) is a call for open source urban coding through embodied infiltration. Now that explorers have touched that voidspace, felt where it can take them, and published that wonder for others to see, where the environment is written in closed code, new generations of urban explorers will hack it until it's open source again as in the quarries of Paris. Touching, feeling, doing and experiencing, the real bodywork behind urban exploration,

...has the capacity to dissolve boundaries, to make proximate that which was far away, and in doing so not only rearrange our metaphysics of intimacy and distance, but pose a danger to any and all systems of order that rely upon distinction and separation. These bodies 'resist, exaggerate, and destabilize distinctions and categories that mark and maintain bodies'... 'signifying pleasure and desire as sites of insurgency' (Dixon and Straughan 2010: 454, referencing Springgay, 2003)

In our last and final chapter, I will discuss the political turmoil that arose from our increasingly brazen forays into the city and use those reflections as a point of departure to discuss the most pressing, and perhaps exciting, issue facing urban exploration today – what is going to happen next?



Figure 167. The author exploring the Paris Metro, learning the city from the inside out, Paris, photo by author

## Chapter 6 – Pedestals built on crumbling stone

“Exploration is a political act.”  
– Alistair Bonnett (1996a: 7)



Figure 168. Brosa wiggling through a security loophole, Abbey Mills Pumping Station, London, photo by author

As I have shown throughout this thesis, though there is an extensive social history of seeking out off-limits spaces. Like most contemporary urban explorers, “Team B” began as a group through exploring abandoned hospitals and industrial sites. The crew quickly finished what there was to see in greater London and then ventured into Europe to continue discovering new places, eventually pushing ourselves to our existential, embodied and emotional breaking points by sleeping in ruins for weeks on end, overindulging in urban toxicity and searching for more visceral connections to historic places. After exploring the Burlington government bunker in Wiltshire, we joined with London “Team A” at Marc Explo’s 29<sup>th</sup> birthday party on top of King’s Reach Tower, reformed the group as the LCC and began infiltrating utility and transportation tunnels under the city together. Returning to

London, the group explored a vast majority of London's drainage systems including what used to be the Fleet, Westbourne, Effra and Tyburn rivers, now sewer networks harnessed by the beautiful brickwork of the Victorian engineer Joseph Bazalgette and the builders who made his plans a reality, all of whom the group began to feel particularly connected to across four centuries. As a result, the group became increasingly melded into the fabric of the city and, not unproblematically, enraptured and inspired by those Victorian creations and imagery. As we then moved from one component of infrastructure (sewers) to others (bunkers, utility and transportation networks), the group largely failed to interrogate the increasing subversiveness of their activities by vehemently denying any political agenda or dogmatic motivation in favour of a continuing chase for unique photographic opportunities, sensory and emotional indulgences and community projects. However, as I have shown, where I may point to overarching driving imperatives, it is just as problematic to attempt to reify a coordinated explorer ethos, individuals simply followed their own desires, did their own edgework.

By 2011, the group had climbed London's most notable construction developments, cranes and rooftops including Heron Tower, Strata, New Court, Eagle House, Temple Court, 100 Middlesex, Lantern Court and the Shard. As a newly organised urban exploration collective, we together pushed the boundaries of London urban exploration to a point never before seen, sneaking into the London Underground to relocate and photograph every disused underground station in the system. By the summer of 2011, the Consolidation Crew was in full swing, sometimes in the city four or five nights a week, cracking new sites almost every time they went out. The list of places the group wanted to infiltrate

dwindled. However, a few places remained in mid-to-late 2011. First was the London Mail Rail, a disused Post Office underground railway system. Next, the BT deep level tunnels, the central nervous system for British Telecom. Finally, the most daunting challenge: the unmapped and highly secure government bunkers connecting Whitehall, Parliament and Scotland Yard. The group knew that if they relocated those final places, they had the opportunity to earn worldwide respect for the discoveries. Most importantly though, they could feed their increasing addiction to the adrenaline rush of live urban infiltration and novel discovery.



Figure 169. The group cracked Tube stations never previously explored, Brompton Road disused station, London, photo by "Gary"

As a researcher, I negotiated my own edgework, walking a line between being elated that I was a part of such an incredible series of events and terrified we would finally be caught on one of our escapades. Leading up to the secure file storage and my involvement in our London Underground infiltrations, I was becoming progressively paranoid about potentially losing my visa to stay in the country if arrested by the British Transport Police or worse, military police. I was

also beginning to get involved in other movements in London such as squatting, students protests and eventually Occupy and was becoming increasingly frustrated that many in the group continued to want to operate in isolation, acting as if their actions were not beginning to overlap heavily into other critical urban practices. I was also, of course, just as addicted to the adrenaline rush of what we were doing as everyone else and had trouble sidelining it, no matter how logical the rationale.

I was becoming mentally unstable, sleeping all day, running underground all night under high stress and then trying to sit in the library writing all day. I could not find a balance anymore between my life in the LCC and my life as a researcher on a long-term research project. So, I made a very difficult decision to leave London to write this thesis over the summer of 2011. In hindsight, it was surely the best move I could have made. As a crew, we were becoming bolder with each success and it was obvious at some point we would be caught. Days before I left, Winch called and asked if I wanted to go for one more exploration in Clapham, a fitting goodbye given I spent most of my time there. As we walked up to the one of the Clapham bunkers, I was surprised to see the palisade fencing had been disassembled. When we walked down the 30 meters of stairs into the deep shelter, there were dozens of explorers in attendance from all over the UK, in attendance to see me off. It was one of the best nights of my life, reaffirming for me everything we had built together and everything I was walking away from. Getting on the plane to Los Angeles, leaving the LCC, was very difficult for me and in one final gesture to the crew, I left the keys behind to my squat in Clapham and told them to make good use of it. They immediately occupied the building, dubbed it the "Brad:pad/Team B war room" and started planning the last three "epics" without their ethnographer.





Figure 170. The author with Drainpipe at my leaving party, Clapham bunker, London, photo by Cogito

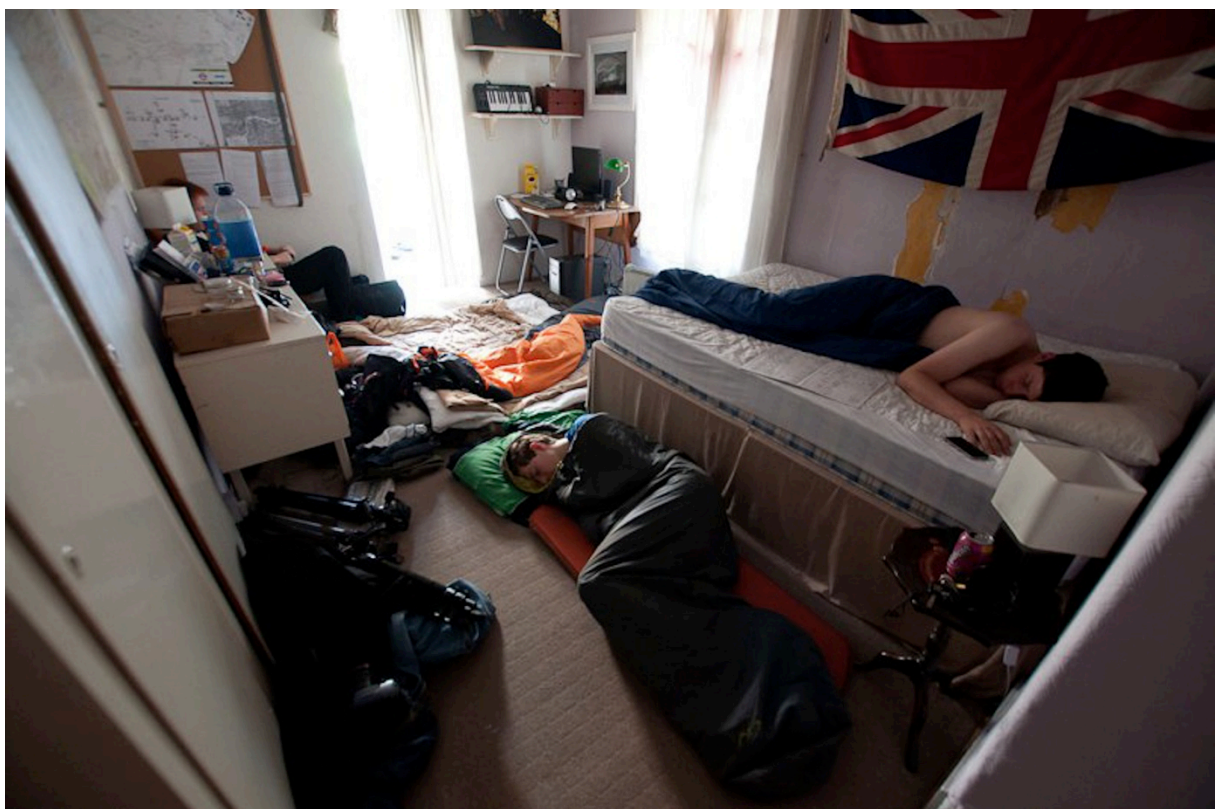

Figure 171. The author's squat in Clapham, converted into the Brad:pad/Team B war room, London, photo by Cogito

## The myth of the Mail Rail decoded

“Revolutionary movements to not spread by contamination but by *resonance*.”  
– The Invisible Committee (Committee, 2009)

As the LCC research and explored one London Underground station after another in 2010 and 2011, we also become aware of a separate system of nine stations far below the city used by the Post Office to transport letters across London. Supposedly, it was now mothballed and could somehow be accessed, though we had no idea how. However, on Halloween 2010, ravers temporarily occupied a massive derelict Post Office building and hosted an illegal party of epic proportions. When pictures from the gathering emerged, we were astonished to find that a few of them looked to be of a miniature rail system somehow accessed from the building.<sup>52</sup>

Silent Motion, Winch, Statler and myself snuck into the building a day later. Statler and Winch kept watch while Silent Motion and I wedged our bodies between two walls and wiggled up to an open window on the first floor. It was absolutely ravaged inside. After hours of snooping, we finally found what we thought might be a freshly bricked-up wall into the mythical Mail Rail the partygoers had inadvertently found. We went back to the car and discussed the possibility of chiselling the brick out. We decided that, given how soon it was after the party, the place was too hot to do that just now and we walked away, vowing to try again in a couple of months.

About a month after I had left London, I got a message from Statler that said, “I think we found it mate” (Statler, via Facebook message, April 2011). A day later,

---

<sup>52</sup> <http://www.guardian.co.uk/society/2010/nov/07/underground-rave-culture-recession-facebook> (accessed 8th November 2010).

pictures were up on the forum. They were beautiful. The crew had found a complete system of nine stations underneath London, full of small trains or “mini yorks” used to move mail around the city. Statler wrote on the forum that “it's unreal how this hadn't been done before, I mean all the access info was online via sub-brit (Subterranea Britannica) and all it involved was a little bit of climbing” (Statler, UIS forum post, April 2011)! It was a clear indication that as much as urban exploration is about skill, it is also about luck and persistence. The stories emerging were like something out of the Royal Geographical Society Archives, miles of tunnels running right underneath central London that almost no one knew about. The crew made multiple trips into Mail Rail in June and I asked them to write about their experiences. “Gary” wrote that himself, Otter, and Site made the journey from Paddington to Whitechapel. Including the journey back, they walked roughly eight miles of tunnel. He continues,

The tunnels become tighter approaching the stations, meaning stooping was required at regular intervals throughout the trip. Towards the eastern end of the line, calcium stalactites were more abundant, hanging from the tunnel ceilings, and gleaming under the fluorescent light. This produced a very real feeling of adventure, like we were in an Indiana Jones movie, in some kind of mine or cave system with wooden carts and the smell of damp throughout. During this first of my two trips, the feeling of surreal adventure was most prominent and the constant reminder that this incredible piece of infrastructure was indeed underneath the centre of London was a bizarre realisation. The stations themselves had an air of secrecy to them. Hearing the distant echoes from some of the live sorting offices above (particularly Rathbone) was exciting yet comforting (though others found it rather unsettling; it's funny how different sounds/situations provoke different reactions when exploring) and emphasised the fact that we really had wiggled our dirty little fingers into one of the myths of subterranean London, peeling it back for all to see (“Gary”, via email, April 2011).

Inside the Mail Rail, Erle wrote that it was almost comical, “it felt like we were inside a model railway (with it bearing a striking resemblance to the full sized tube)” (Erle, via email, April 2011). Statler added,



Figure 172. Accessing a holy grail, London, photo by Silent Motion



Figure 173. Mothballed subterranean industry, London, photo by Statler

It was hot, sweaty, dank, wet.... it smelt like a mouldering hospital in parts and was pretty cramped in the tunnels. The stretch between Liverpool Street to Whitechapel was a real neck breaker in places and a long walk probably around 45 minutes. There were also a lot of calcium stalactites that would snap off in your face and hair it was obvious that people hadn't been in the tunnels for a very long time. The same goes for the stretch between Bird Street and Paddington which was also another long walk of small diameter tunnels (Statler, via email, April 2011).

Although accessing the system was no easy feat, like many places, once inside Ercler writes that "the threat of security felt a very long way off for all but one of the stations" (Ercler, via email, April 2011), even whilst dodging CCTV cameras, reinforcing my comments in chapter 3 that once past the liminal zone of motion sensors, security guards and cameras, explorers are relatively free to do as they please in derelict urban spaces, one of the liberating elements of the practice. Badman described the ways in which,

Unlike the usual stress of Tube exploration, we were all totally relaxed, free to chat and enjoy ourselves as it got later and later into the night. It was a luxurious experience and was reminiscent of the feeling of exploration when I first began; pure admiration of my surroundings (Badman, via email, April 2011).

For four days, the crew went back again and again, running longer down the lines to additional stations, turning down security cameras and occasionally setting off alarms and then scurrying out of the system before anyone arrived. Finally on the fourth night, their luck broke and Statler, Patch and Winch were busted. Winch tells the story:

After enduring a tense period on the street waiting for a period of inactivity both within the large compound and outside, the three of us swiftly made our way over the wall and down the shaft, pleased with ourselves for such a well executed entry. Having continually checked for unwanted attention and seeing nobody, we assumed we were safely in.

"Right lads, stay where you are. The police are on their way. You're fucked". Postman Pat was bellowing down the shaft at us. In a second we froze, before hastily dropping down ladders and finding a bolted door, a ladder that had previously assisted access to other parties now nowhere to be seen.



Figure 174. Tunnel vision in the Mail Rail, London, photo by "Gary"



Figure 175. Mini York trains in the Mail Rail, London, photo by Patch

The door seemed impenetrable, nothing there to assist the 20ft climb. The frame being metal it flexed enough to squeeze a hand through and unbolt the door. We ran to the tunnels. Entering the pitch black we stopped for a second to take stock, aware that going down the wrong tunnels could take us away from our intended destination where we had a car parked, roughly a mile away.

We trod quickly and carefully, finding a pitch black station to exit from maybe 20 minutes later. No time to hang around, just an opportunity to exit through a door onto the street and away from the now screaming alarm, away from the Mailrail that would no doubt be crawling with police soon.

Back at the car, we packed our kit away and headed back to collect our other vehicle. A Police van flew past, sirens blazing, blue lights on. We breathed a sigh of relief. We could have been fucked. Postman Pat could have been right.

By our access point was 3 police cars. We collected the other car and departed, having arranged to meet "Gary" at a nearby station for some other activities in the area.

An hour or so later, the city was crawling. Police cars bolted up and down side streets, combing the area for those they'd assumedly seen on CCTV. We met with Otter and [Siologen] too, and congregated on a non-descript street to arrange ourselves. Sirens blazed. A van buzzed down the street. The siren stopped. The van stopped. The questions started. Postman Pat and Mrs Goggins arrived. "I've seen him on CCTV. And him. And him. Arrest them all, we've got all of them."

The instinct is usually to depart pretty sharp after an 'on top' situation like the one we'd just found ourselves in. The other desire is to stick around to see what happens. We just made bad decisions. They'd seen the CCTV from the last 4 nights and were hiding behind the access, waiting for somebody to come. Getting seen there wasn't the problem, it was sticking around in the same part of the city that we'd just caused problems in.

It was Siolo's smooth talking to the police that ultimately saved us a night in the cells - by the end Postman Pat and Mrs Goggins were annoying the police more than we were and we were told to leave and not come back, having been searched.

Collectively we've achieved a lot in 2010, and even more so far in 2011. It's time to take stock, look at some of the decisions we make and see where we can make better ones. Getting out of the city would have been the best decision to make last night, but it was the desire of the group to see more, do more and ultimately push the boundaries that resulted in the bust. We're not all invincible, we do get caught from time and time and to avoid it, we need to learn how to minimise the likelihood of it (Winch, UIS forum post, April 2011).

The crew was let off with a warning from Met police officers who told them that they knew what the group had been up to and with the royal wedding of Kate Middleton and Prince William taking place in just weeks, advised us to stay out of the underground – divers would be placed in the sewers and lids welded because of the LCC's nightly activities.<sup>53</sup>



Figure 176. Snappel, Urban Fox and Siologen in the Mail Rail, London, photo by Urban Fox

<sup>53</sup> <http://tvnz.co.nz/royal-wedding/robust-security-plan-4143132> (accessed 28th April 2012).



Otter was the first to post the story of the Mail Rail on his blog. It hit a number of major news providers within hours and went viral, pulling in millions of hits across the globe and crashing his website. The LCC was splashed all over the Internet for weeks, leading to another backlash from the wider community and dejection amongst the crew as people realised the list of places left to explore was dwindling and the pressure on authorities to stop us was now increasing. Otter wrote in his post, “in a way, its with a bit of sadness I write this, when your group has conquered the best location a city or country has to offer, those remaining will often seem tame by comparison.”<sup>54</sup> A few explorers made comments to the effect that “London was dead now” and there was “nothing left”, while Patch contended that “there will always be more to explore, this isn’t about places guys, it’s about experiences” (Patch, UIS post, April 2011).

Soon after, the crew also found their way into the Kingsway Telephone Exchange and BT deep level tunnels which Silent Motion, Statler and I had scoped sometime earlier. However, as with the secure file storage, the location was too sensitive to share and after the negative press from Mail Rail, the crew kept those photos internal. It was yet another indication of how the group dynamic had changed over the past few years, becoming increasingly insular. It was clear that the photographic aspects of the practice now had far less to do with group motivations for exploring than the experience of cracking new sites. The list of locations to be done was a list of places no urban explorers had ever even considered breaching, leading Patch to suggest “we are not urban explorers anymore, just participants in recreational criminality” (Patch, October 2011).

---

<sup>54</sup> <http://www.silentuk.com/?p=2792> (accessed 13<sup>th</sup> August 2011).

We got inside information soon after the Kingsway breach that the incident was being investigated by the London Metropolitan Police Criminal Investigation Department (CID). “Gary” then wrote “fuck, if it was cid... guys we're getting into serious UE now” (“Gary, UIS forum posting, June 2011). Despite the Mail Rail bust, everyone was incredibly energized again. The last places on the list were the abandoned British Museum Tube Station and the secret government bunkers. There is no doubt, looking back from the safety of hindsight, that the group had lost our sense of what they could reasonably get away with. At the same time, it was clearly liberating to experience that level of existential freedom, to feel we had that we were confounding multiple police forces, outstripping them at every turn. The group had so intimately fused everyday life with deeper desires to do the impossible that we had completely reformulated our relationship with the city and ourselves.



Figure 177. Recreational criminality, London, photo by Patch

## House of cards

"You might not see things yet on the surface, but underground, it's already on fire"  
– Y.B. Manguwijaya (Klein, 2000: cover)



Figure 178. An error in the code, London, photo by author

By the Spring of 2011, after infiltrating the secure file storage, the London Underground, the BT Tunnels, the Olympic Stadium,<sup>55</sup> St Pauls Cathedral,<sup>56</sup> the British Museum,<sup>57</sup> the Shard, and especially Otter's million-hit post on the Mail Rail, security started tightening up around the London in a severe way. In fact, Patch had found a report online from a consulting firm for Transport for London, advising them of the need for a £240,000 overhaul of security "following a review of vulnerable access points across the network by London Underground Ltd", where "the review identified a number of locations where works were required to prevent individuals from gaining unauthorized access through surreptitious

<sup>55</sup> <http://www.adventureworldwide.net/stories/olympic-sized-ambitions> (accessed 2nd January 2012).

<sup>56</sup> <http://www.partoftheplan.org/2011/06/st-pauls-cathedral.html> (accessed 2nd June 2011).

<sup>57</sup> <http://eofd.co.uk/512/night-at-the-museum-rooftopping-the-british-museum> (accessed 2nd June 2011).

means".<sup>58</sup> I verified what the Met Police had told the crew at the Mail Rail bust, not only had we gained access to all these places, but the Met and British Transport Police knew we were seeing them. We imagined they were probably angry, stumped and interested in what we were doing given, unlike graffiti writers, we left little evidence we had been there and were not even posting photos online anymore. The group would soon find out the authorities were more interested than we knew.

Holidays were a good time for the crew to infiltrate especially difficult sites, given most workers took time off then, including security. On Easter day, weeks before the royal wedding, two separate groups went out to explore two locations. We still needed access to the British Museum abandoned station, the last on our list of Tube locations to complete the set. A few of the explorers had found that by squeezing through a vent shaft into a utility closet, access could be gained to Russell Square station (which was live). By then running down the escalator and across the platforms, through the station after closing, down the Piccadilly Line, on to Holborn and then switching through the tickets halls to the Central Line tracks (past dozens of CCTV cameras), they could make it to British Museum. They went for it. Unfortunately, someone at central control was actually watching the cameras and saw the group of four running across the platform at Russell Square masked up and dressed in black. The police, including an anti-terrorism unit, showed up, arrested everyone and did a bomb sweep of the station, shutting down first service from Russell Square the next morning.<sup>59</sup> Patch wrote me later saying,

---

<sup>58</sup> <http://www.theclancygroup.co.uk/casestudies/52/> (accessed 11th May 2011).

<sup>59</sup> See <http://www.bbc.co.uk/news/uk-england-london-13409831> (accessed 30th May 2011) and <http://www.thisislondon.co.uk/news/terror-alert-at-77-tube-station-blamed-on-four-urban-explorers-6397538.html> (accessed 29th May 2011).

The most hilarious bit though was when we were initially arrested and the guy asked us what we were doing, I said just looking around and taking photos and he was like "bollocks mate you're activists, people don't take photos in tunnels" (Patch, via email, April 2011).

At the same time, Silent Motion was at Adelaide house, an excellent rooftop for photos over the Thames near London Bridge, when he was spotted by a security guard, who rushed and grabbed him as he tried to climb the hoarding to get out of the site. When the police showed up, the security guard claimed that Silent Motion had "assaulted" him. On the back on the Mail Rail bust, as well as a few other detentions, the police connected Silent Motion with CCTV footage in the Kingsway Telephone Exchange and the whole story started to unravel. It was now clear that authorities in London knew who we were, what we were doing, and were determined to put an end to it. Within 48 hours, multiple explorers had their houses raided. Laptops, cameras, keys, maps, tools and costumes were seized and CCTV footage matched to specific individuals. All at once, blog posts were linked, aliases unravelled and the whole thing came toppling down. It was incredible actually how fast it happened – it was clear we all had files before the busts.

As we tried to quickly change the passwords on our web forum before the police arrived at the squat, Ercle joked that "I find it ironic that for a group dedicated to finding holes in security, we are struggling so much with our own" (Ercle, via email, May 2011). In the end, the crew took down the domain as the police were kicking in the door of the Brad:pad/War room in Clapham. Patch wrote about his end of the experience in an email to all of us from a public computer,

As you may know myself and some of our friends spent a day at her majesty's pleasure in relation to being caught in the tube trying to get to the final abandoned station on the list. As a result we've had our homes and our parent's homes turned over and phones, computers, cameras, photographs, negatives, memory cards and various other bits seized by the Major Investigations Team, including photos of MR [Mail Rail] and KTE [Kingsway Telephone Exchange]. We've been bailed and are to surrender

at various times on Friday to either be re-arrested/re-bailed in light of new evidence or charged on the spot. Luckily [LutEx] was not with us at the time but witnessed the Brutish Transport Pigs arriving and managed to report what had happened back to you via the forum. Its also my understanding that [Silent Motion] was also detained on the same day for something different initially but was later further arrested for something that affects many of us including 3 quarters of the party I was arrested with. Fortunately [Statler] realised that with the BTP and City having seized 5 phones and at least 5 computers they could easily access the forum if any of us had autologin ticked so he managed to pull the domain name. This wouldn't have happened instantly but the site was unreachable by 11am yesterday when I checked on a friend's computer. As a secondary measure I have made an offsite backup of the server and database then completely wiped both from the hosting account as my FTP is set to autologin on my laptop. I've also changed my passwords for emails, msn, flickr (and removed relevant images) etc so the only evidence of the places we've been they'll have from me at least is the photos on my computer and the prints they seized. Unfortunately despite removing most of the incriminating material I fear this won't be totally sufficient to avoid involving more of you in the investigation(s), as every phone seized on Monday probably has texts on it that will at least hint at some of your involvement in the tube/KTE explorations. There are also chat logs from IM conversations as well as group photos in locations on our computers.

I don't really know what to suggest you guys do next if anything or if you should even be worrying as much as I am (some of you clearly have nothing at all to worry about), but I thought I should keep you updated about what I know to at least give you some chance to prepare for a knock at the door, as well as to notify you of the forum's situation. I'm hoping to go and see [Silent Motion] tonight to find out what happened to him - I haven't had an answer from his phone so assume it has been seized. Our bail conditions include a 2300-0600 curfew and a ban from being in non-public parts of the tube network so I'll be at the [squat] every night at least until Friday if anyone wants to come up and chat more about it (Patch, April 2011).

Weeks later, Patch (who was now on bail), Hydra, the Badman and Uselesspsychic went back into the Mail Rail and started one of the electric trains. In what Patch described as "one of the most exhilarating moments of my life" (Patch, May 2011), they rode it four miles down the tracks where they ran into a track not set properly and derailed the train. The damage was minor but by then, the police had surrounded the building and all four explorers were arrested. In the police interview, Badman and Patch informed me the police investigators pulled out 91 pages of writing from my blog.



Figure 179. Infiltration paraphernalia, Team B War Room, London, photo by author



Figure 180. Some keys open more doors than others, London, photo by author

I later verified this in October 2011 when I returned to London and saw Patch's indictment in a 2-inch binder. The evidence log read:

"MG6C ITEM 7. 91 pages of the website <http://www.placehacking.co.uk>, describing the acts of photography in abandoned buildings and Tube stations including the mail rail."

All four explorers from the Mail Rail arrest ended up in Crown Court by November 2011, facing quite serious charges of damage to government property and aggravated vehicle taking, which I attended, having returned to London. Looking back to Marc's comments in chapter 4 about the fact he did not feel a need to be offered "a say" by the state, he would simply do what he wanted with or without consent, it was clear that our actions had now been significant enough that the LCC was on the "state" radar, our subversive methods turning transgressive. In fact, the investigating officer complimented us on our tactics, telling us we were "incredibly difficult to catch in the act" (Officer's name withheld, May 2011). The same investigator later told Patch, "I normally deal with deaths, muggings and suicides – looking through your photos is delightful in comparison" (Officer's name withheld, May 2011)! By this time the squat was also falling through. It had lasted the summer but the owners were finally figuring out which papers to file to get the crew out of the property. After eviction, the group cracked two more squats including one worth £1.2 million in Pimlico, but they did not have the numbers anymore to hold places properly. Eventually everybody moved home.





Figure 181. The boarded up Brad:pad/War room in Clapham, London, photo by author

At the same time, the newspaper articles about the bust, in combination with our steady stream of blog postings and our release of *Crack the Surface* (video 10) had turned into a media frenzy. I got a cold call from the BBC World Service wanting to do a story about the Mail Rail postings.<sup>60</sup> We were busier than ever but not exploring as we used to. Winch wrote on his blog in May 2011,

The last month has been a drag. Various arrests and police crackdowns has nulled the wonderful spike of accomplishment we've had in the London scene and with the Brad:pad gone, there's an 'end of an era' vibe with most that I've spent time with lately.

The subterranea hasn't been ventured into by myself in recent weeks. Stories of terrorist alerts in the tube and the sewers, in both London and New York [from another crew we were connected to], have concerned me enough to give the city sub structure a wider berth than usual. Many places that we'd previously have waltzed into have been neglected, the love of these spaces tempered by what might happen in the event of authoritative intervention.

We've hit so many places but again, we've missed so many too, through demolition, completion, concreting up of access. This drying up of aspiration within this section of the community must surely be the point upon which we step back and look at the alternatives to traditional 'urban exploration'. Turning our playground into our living room has been an aspiration for so long and taking hold of this mass of brick, glass and steel and turning it into a space we can utilise for everything we could need must surely be the next step in this wonderful urban adventure.<sup>61</sup>

By the time I had returned to London with my draft thesis in hand, the crew was not venturing into the Tube network much anymore. In fact, Silent Motion was the only one still living in London. The group was still getting together often and one of the first things we did (after they threw me a homecoming party in the Holborn Viaduct) was to get on top of one of the Barbican towers. The crew was exploring, having barbeques, draining and climbing buildings, but it was obvious that the Golden Age of The LCC was over. 2008-2011 would always be thought of as the

---

<sup>60</sup> <http://bbc.in/iz9eYL> (accessed 12th Feb 2012).

<sup>61</sup> <http://www.thewinch.net/?p=2949> (accessed 12th Feb 2012).

years urban exploration blossomed in the city and I was proud (and lucky!) I was there for it. But our work had also left behind a lot of wreckage.

When the news of the court cases hit the streets and the London Evening Standard wrote an incredibly negative article about us, implying we had “broken into” everything we explored (which was not even remotely the case),<sup>62</sup> there was another huge fallout in the wider UK community, similar to the Burlington incident. Other explorers started calling us the “London Criminal Collective” which Patch quite liked. Their main point of contention was that it appeared we had broken into some locations and then by labelling ourselves as a “crew”, we painted the wider “community” with a similar brush to graffiti artists which would bring urban exploration more to the fore for police interventions. The explorer Speed wrote on *28 Days Later* that “theres no doubt [about what] they have achieved but what they have also done is build themselves a pedestal, a pedestal that way too high and built of crumbling stone.”<sup>63</sup> However, Siologen then replied to the post, saying,

As for the activities of LCC... lol, bottom line is they did what no group of explorers, in the 10 odd years UE has been going on in the UK has ever done. They fucking rinsed the city of Greater London. Tube, Sewer, Pipesub, MailRail, the lot. The reason its taken 10 years, is because its by far the hardest. In 16 years of exploring, in a variety of different countries, ive never encountered a city as hard to crack as London. But LCC did it... as a 'crew'... because one person alone couldnt have done it (Siologen, November 2011).<sup>64</sup>

---

<sup>62</sup> <http://www.thisislondon.co.uk/news/urban-explorers-enter-londons-landmarks-6366652.html> (accessed 12th Feb 2012).

<sup>63</sup> <http://www.28dayslater.co.uk/forums/showthread.php?t=66190> (accessed November 2011, thread removed as of January 2012).

<sup>64</sup> *ibid*

## The alternative

Throughout this thesis, I have tried to sketch out a rich picture of what urban exploration is, why people get involved and why it might be important. It is clear we are part of a community. However, given the level this group was operating on and our disconnection from the rest of the UK communities, whether we were urban explorers anymore or just a group of friends “getting up” in various ways was under question. Patch wrote on his blog in November 2011,

We are not “Urban Explorers”.

Don’t go crying to whoever will read your 40+ pages of digital diarrhoea about how our relentless assault on all things untouched above and below London has “ruined it for everyone” – if the media and the law want to confuse us, that’s unfortunate for you but of little interest to us. Yes, we’re cunts. All we care about is ourselves. We don’t care if places get “locked down”, if the heat is on you for something we did, or if you think its selfish that we only told our friends that we’d opened somewhere up.

In short – its our doorstep, we’ll shit on it if we want to. We make no apologies if you get splashed, you were probably standing too close.<sup>65</sup>

As I have shown throughout this thesis, this community, as much as there is one, does operate by loose consensus but there are drastically different views as to how and why urban explorers undertake their practice. “Team B” and the LCC had discovered more than any group in London history, but by the end of 2011 we spent as much time throwing parties and working on larger projects like the *Crack the Surface* film (video 10) as climbing cranes and going in drains. When I asked Winch about it, he suggested we had reached a point that people needed to move onto “urban exploration alternatives” (Winch, December 2011) including illegal parties and film screenings, street art, graffiti, urban camping and squatting, all of which felt like exploration as well on some level after what we had been through - it was, as Winch said, “just friends getting together to do exceptional things” (Winch, December 2011). The scene was fragmenting in different directions,

---

<sup>65</sup> <http://not-legit.net/423> (accessed 12th December 2011).

partially because we had rinsed the city but also because we had found our edge and realised that the edge was, as Statler had said earlier, “up to the individual”. The urban exploration “scene” in the UK had become a battleground for control over how that practice would be perceived and remembered. Of course, my blog, journal publications and this thesis also became points of contentions and will likely remain so.

With these things in mind, it is worth revisiting these tales of urban exploration to again consider the rise and fall of the LCC and the London Golden Age of urban exploration, both what it meant at the time and why, in hindsight, it may also appear significant.



Figure 182. The author hiding from drivers in the Metro, Paris, photo by author



Figure 183. The author lying on the tracks in the Arsenal disused station, Paris, photo by author

**Future fragmentation**

“Well, if it were easy kid, everybody would do it.”  
–James Coughlin, *The Town* (2010)



Figure 184. Watching the Bonfire Night fireworks from a chimney of Battersea Power Station, photo by author

The urban infiltration scene was so enticing to everyone during the London Golden Age because no one really knew what was happening, it was a period of accumulated frustration unleashed on the city, fuelled by a collective of close friends who put an amazing amount of effort into their work over those years. Questions about what urban exploration was and would become, who would get involved, why it was happening, what its boundaries were and when and where it would end were still being probed. No one knew how to make money out of it, the crew did it for the love of doing it (with the exception of myself who arguably was the only one making a living from our exploits). The feeling that it was for us and that we were writing the rules as we went along was incredibly empowering. Many in the group expressed a growing deep admiration for the city as they explored it.

Over the period of the Golden Age, urban exploration became the subject of countless pop-cultural speculations and attempts at co-option, ranging from a new model of Converse shoes<sup>66</sup> to amateur documentaries<sup>67</sup> to an iPhone app<sup>68</sup> (hundreds of abandoned locations just \$2.99!). Most attempted to capitalise, perversely, on the 2008 financial crisis by dressing up dereliction as something marketable and hip, especially where it can be transmuted into “art”, with urban explorers as the artists in residence; but it was just another face of gentrification (Butler, 2003, Harris, 2011). The tropes of urban exploration became multitudinous and infuriating – endless Flickr photos of guys in their mid-twenties venturing from their gentrified suburb to “explore” something dangerous (usually in Detroit), some husk of a building left behind in the wake of economic devastation where they were going to “get in touch with its history”.

However, what I experienced with the London explorers indicates more than a bizarre subcultural group hobby or passing fad. What the group built together was a deeply bonded community of people committed to a very specific set of goals, importantly, built not on the desire to reap wealth or fame but to actually see places that very few people had ever seen – places that were right under our feet in the city. The amount of research and effort required to access many of these places rivals the great explorations of the 20<sup>th</sup> century. In this way, urban exploration is connected to those earlier forms of exploration that have been taking place since pre-historic times, perhaps feeding a neural desire for discovery, but it also spoke in a unique way to this specific period of time, as I have shown. While we, as a crew, clearly pushed some boundaries past their breaking points, explorers of all

---

<sup>66</sup> <http://www.youtube.com/watch?v=xoj7WEgzY7k> (accessed 2nd June 2011).

<sup>67</sup> <http://www.urbanexplorersfilm.com> (accessed 2nd June 2011).

<sup>68</sup> <http://itunes.apple.com/us/app/abandoned/id328934720?mt=8> (accessed 2nd June 2011).



calibres raise an interesting challenge regarding the right to venture into public architecture such as sewer networks in the cities they reside. Where late modernity has buried these systems in an attempt to present a frictionless interface that is to remain unseen, unquestioned and taken for granted, urban explorers, as active participatory citizens, are asserting the right to know how these things work, where they exist and what they connect to. They are then publicising that illegally obtained, localized expert knowledge - leaking it into the public realm, so to speak.

It is an interesting question, given we purportedly live in an open, free and transparent democracy, why these activities should be seen to be “transgressive” or even “subversive”. While exploration of the “wilderness” is seen as noble and even a “productive” use of time, exploration of the “urban” is found to be threatening. It is yet another example of a weary modernist binary of in place/out of place (Cresswell, 1996). Whether the effort of the group reworked that binary at all by showing people that the urban environment could and should be explored, that it was worth the effort invested, remains to be seen. What urban explorers do may be seen as challenging to authority but I have shown here the goal here isn't revolutionary. The kind of knowledge and experiences that urban explorers seek and find, hidden in plain sight, is exciting, empowering and, as I hope I have demonstrated, ultimately has less to do with fetishising the aesthetics of decay as popularly perceived and more to do with creating a new type of relationship with place, one not offered but taken. It's a project of enthusiasm (Geoghegan, 2012), an effort to connect in a meaningful way to a world rendered increasingly mundane by commercial interests and an endless state of “heightened” security. As Patch says, if others choose to interpret the actions of explorers as something else

entirely, participants ultimately have little control over that. But the recent civil unrest and global occupation movements in cities all over the world clearly bely a deep societal dissatisfaction I think urban explorers are also a product of and that the actions of urban explorers speak to.



Figure 185. "Gary" just having a look, Belgium, photo by author

As I outlined in Chapter 1, what explorers are doing is certainly now “new” in many ways, but perhaps these explorations have different political implications in this age. Perhaps those fluctuating inferences say less about urban explorers and more about the state of purportedly representative democratic societies where civil liberties appears to be rapidly constricting. It is interesting that as far back as 2003, Liz and Ninjalicious (2003: 2) wrote the following:

Allowing the darkening threat of future terrorist attack or indeed of our increasingly scarce civil rights to deter our curiosity or intimidate us away from expressing our deep appreciation for the hidden and neglected bits of our urban landscapes would be the greatest crime of all. Continuing to support considerate exploration and questioning authority in productive, benevolent, and visible ways will allow us to represent ourselves as what we really are: people who love our cities, not those who wish to destroy them.



Figure 186. The Tribe, King's Reach Tower, London, photo by author

The urban exploration community perhaps deserves to be problematised for its lack of socio-political contextualisation and self-reflection or for the failure on the part of individual participants to interrogate their own desires to capture, collect, protect and control information. There are also obvious openings for critique in regard to urban exploration's historical precedents, fetishism for dereliction, group smugness that can lead to exclusionary practices and powerful but contentious use of imagery discussed in chapter 2. However, urban exploration is also an important grounded process that renders the city legible, transparent and within reach for a wide range of people who feel excluded from its productions and maintenance. It is a practice which costs nothing but produces a great deal. Urban exploration reveals a potential to expose latent possibilities locked behind smooth glass, metal and stone. It reveals new worlds above and below us, portals to other worlds, feeling and modalities, alternative landscapes and hidden places behind doors, fences and under manhole covers we pass everyday.

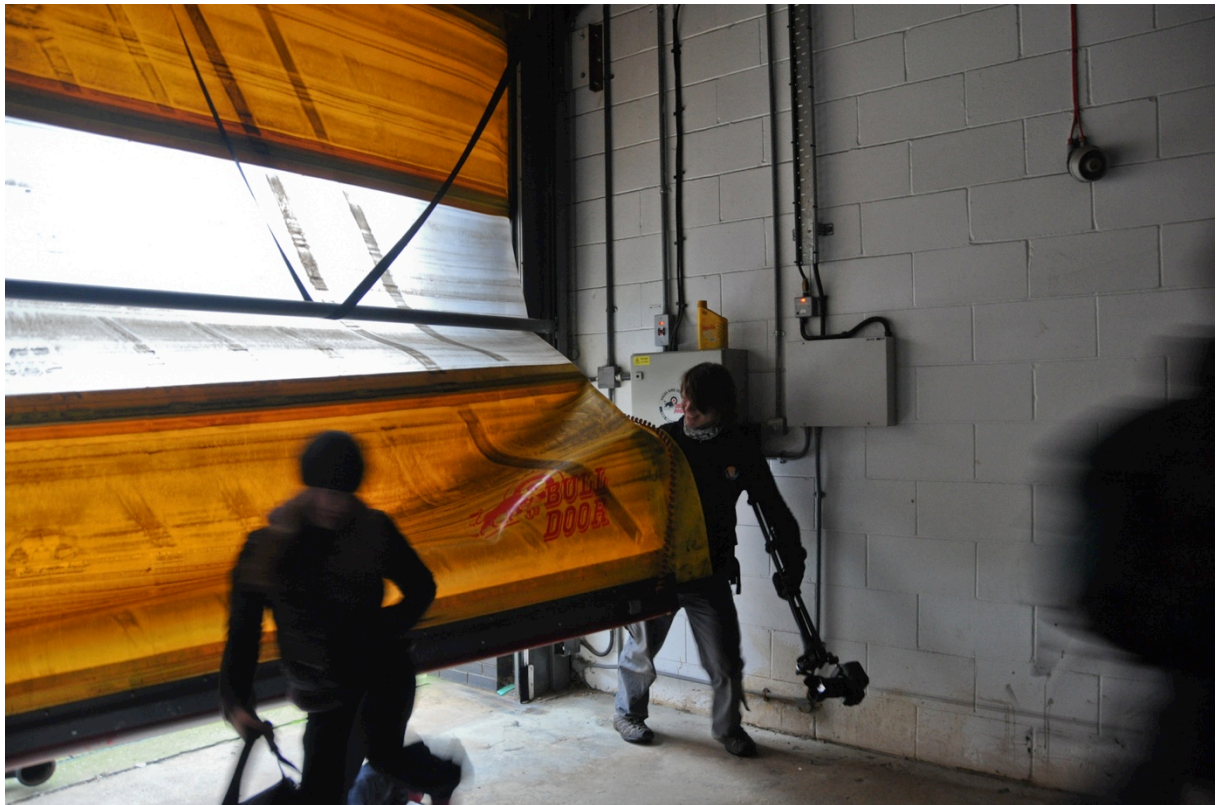

Figure 187. It took a crew, London, photo by author



Figure 188. Explorers exhibit deep care for the city, derelict barge, London, photo by Marc Explo



Figure 189. Silent Motion climbing the impossible, London, photo by author



Figure 190. A portal to our city, London, photo by author

While I am cautious about overemphasising the social and cultural impact of urban exploration as a spatial practice, given the relatively small size of the movement, and insularity, I hope to have demonstrated throughout this thesis that urban explorers are doing important work that goes beyond the production of slick media spectacles. While it can be argued that the relatively esoteric comic book-esque multimedia documentation explorers create often do little to “document” places, the movement has coalesced not because of advancing camera technology or Internet facilitation but because people feel a need for these experiences right now. Explorers do the work of opening closed systems, propriety systems, corporate and government (one and the same) systems, poking holes in the urban security fabric, levelling and democratising place wherever it is smoothed over by neoliberal forces assuring safe banality. But that process of opening up is not limited to place, for as I have shown places are also constituted socially. So, by looking back to the kinds of urban explorations I discussed in chapter 3, urban exploration also works to continually pick at, unpack, unwrap, unfold and complicate clean historical narratives by searching for the stories not told, national and political ambitions never realised, left behind in rotting buildings and decaying architecture.

In chapter 4, we turned those stories around to address the perhaps more narcissistic or selfish components of the practice that began to come to the fore as our urban exploration crew morphed into an urban infiltration crew. I argued that this was a natural, organic progression, for as we continued to play in the city, constantly reconfiguring the boundaries of possibility, new edges of desire manifested themselves in a powerful way, within us as individuals experiencing an ever increasing amount of freedom in the urban environment and skill at

interacting with it, and as a group where our sense of community gelled in a powerful way, giving us confidence to push boundaries harder. With each exploration, the confines we escaped whilst chasing our edge also often collapsed those boundaries, shifting the dirty, the off-limits and the taboo into the realm of everyday experience, losing ourselves to the experience and to places, melding our bodies into the city and the city into our bodies, collapsing self, other, body and architecture. Others followed. Perhaps in the process we also began to lose control of ourselves, of our faculties, but that madness was also liberating, the seduction of being overwhelmed by desire in a way that people outside of the group may have found startling.

In chapter 5 we then literally moved into urban infrastructure, once places of public interest and fascination in the Victorian West, sites for a potential urban social liberation never realised, now closed systems built to be ignored. Modern urban explorers have done the work of rendering those spaces once again transparent and visible through bodywork in the city. By opening those systems, and opening their own bodies to the risk of being inside those systems, explorers take important steps toward reawakening those historical imaginations and conceptions of what is and isn't possible or available for experience, in the context today of an increasing, and we have proven largely fabricated, concern over terrorism and urban security and the spectre of global economic and infrastructural collapse. While our activities looked increasingly deviant as the years passed, that is of course a view from the outside in (Cresswell, 1996). What we succeeded in doing from the inside out was to rewrite our social conditioning, or to put it in terms of the hack, we rewrote the underlying code for our entire mental operating system.





Figure 191. Patch and Otter backcabbng a Metro train, Paris, photo by author



Figure 192. A view we can never see again, London, photo by author

In other ways, as a group we failed to rewrite social codes, falling victim to exclusionary practices, elitism, internet fame and ultimately ending up on the wrong side of the law after making some unfortunate decisions based on overconfidence. This process was not a binary switch from impossible to possible but a meld of those things into a new form of experience which defied our expectations of what could be done and should be done. It shifted our entire notion of what was important in life, changing the emphasis from work, careers and the pursuit of stable family life to an existence filled with exceptional events that challenged and provoked us day after day, with a community of close friends. And this is the most important point to take away from what you are reading. As urban explorers, and as a researcher studying urban exploration, the group did not *talk* about what could or should be done or theorise new possibilities, the group created those possibilities. We undertook the research to find out what had been lost to time and then went out and found it in the world, real work that took place with our hands, bodies and minds as a community we built together. As “Gary” said to me “if you’re in, you’re in, you can’t fake this” (“Gary”, July 2011).

To summarise what I have attempted to demonstrate in this thesis under the broad banner of place hacking, a term that eventually came to encompass the full range of alternative urban project the group undertook, including urban exploration, infiltration, illegal parties, squatting and generally accomplishing whatever the group had the desire to pursue regardless of social expectation or legal constraint, it is worth revisiting the notion of

...hacking as a constant arms race between those with the knowledge and power to erect barriers and those with the equal power, knowledge and especially desire, to disarm them (Coleman and Golub, 2008: 263).



Figure 193. Straddling the edge of the forbidden, photo by author

Through infiltrating the city, urban explorers and infiltrators assert that equal right to power, to space, to history, to investment, development and knowledge. Despite the fact that this age ended with arrests, police raids and seemingly endless court battles, regret is rarely expressed, for as Patch told me,

Brad, I have lived a life few people dream of and even fewer would aspire to. So what if people think I'm a cunt? So what if I end up with a criminal record? So what if it costs me my driver's license, job or court fees? Do you think for a minute that when I'm 70 and in a wheelchair I'm going to look back and think "damn, I really wish I hadn't driven the Mail Rail train or seen Brompton Road station?" Not for an instant, I have loved every second of this, even the busts (Patch, January 2012).

The attentiveness to time and space is evident in everything urban explorers do, from the appreciation of sites of time slippage in ruin space to the awareness of the fact that everything they undertake, be it an exploration of a bunker or spending the summer in a squat, is temporary. The photography of these temporary spatial reappropriations is an attempt to capture and share that experience with others, to create a visual mark of this time and this place, with reference to what came

before, what will come after, and how it is all connected through us. The life of the urban explorer is flavoured by the awareness of the past and future but is always, first and foremost, about the here and now. Again, turning to the work of Coleman and Golub (2008: 264), we can make another important connection to the modern hacker community where,

The morality encoded in this form of hacker practice thus values the process of piercing through locks, disarming security, accessing the inaccessible, eliminating barriers, and reaching the pot of gold behind the locked door – knowing full well that barriers will always come back in some form.

Flipping through my completed thesis, I asked Urban Fox why she got involved with the practice. She gave me one simple answer: “mental and physical barriers are there to be pushed” (Urban Fox, January 2012). While I feel an obvious compulsion to unpack the background, theory and motivation behind this practice, most explorers are content to do urban exploration because they can.



Figure 194. Probing the limits of the urban, London, photo by Silent Motion



Figure 195. A community that must be built, Patch, LutEx, “Gary”, Silent Motion, London, photo by author



Figure 196. Doing exceptional things that aren't on offer, “Gary”, Winch, Gigi and the author, London, photo by author

Explorers of all creeds have been doing so long before a researcher, filmmaker or photographer was there to document it. The desire to explore is inside all of us to some degree, perhaps some just can't, or refuse to, suppress it at the whim of social expectation.

With this all in mind, it may be worth returning to my comments in chapter 2 about my role as a researcher. In January 2012, I met with Marc Expo as I was rewriting the conclusion to this thesis. I told him that, as I wrote earlier, I felt I was quite lucky that I met "Team B" when I did and that I was able to integrate myself into the culture as I had done. He responded, "Brad, you didn't integrate yourself into the culture, you created the culture so that you would have something to study" (Marc Expo, January 2012). Marc's comments haunted me for weeks. Although I think most of what happened would have happened with or without me (as evidenced by what I missed over the summer of 2011 while I was away writing), there is no doubt it would have happened in a different way. Perhaps if I had not started this research, there would be no LCC. Whatever my involvement triggered, I do believe it's a vital component of my ethnographic work to acknowledge that role in the rise and fall of the "Team B" and the LCC. It was the most incredible thing I have ever been a part of, this alternative urban project.

Although the end of these tales of urban exploration are not exactly cheerful, this research remains a celebration of urban exploration as a single plateau of community creation and populist practice, echoed by hundreds of other community-building processes taking place all over the world right now. I believe that when we look back on this period, we will realise we were involved in nothing less than a cultural renaissance, when local people began to take control of their

rights to the city, many times, as with urban exploration, not through force but in more playfully subversive ways in the midst of failing economies, governments and the erosion of democratic ideals.



Figure 197. There are always new adventures to be had, Berlin, photo by author

These movements, seemingly isolated from one another, indeed even at times hostile to one another, nonetheless are working to undermine singular authoritative narratives over space through the creation of new relationships to places, open coded for the world to see. Urban exploration, as one of these activist practices, reconfigures places in ways that can be shocking, beautiful, confusing and bizarre but ultimately bear a particular rare authenticity. The spaces explorers find, open and create spring from something profoundly human and social, a process of creation seeded from a visceral right to define places on our own terms, not in opposition to but regardless of social expectation.



Figure 198. Another side of what you know, revealed by urban exploration, pre-metro, Antwerp, photo by author

Given I could barely comprehend what was happening while I was a part of it, I wouldn't dare predict where urban exploration will go from here, but there certainly seems to be a growing interest in it, which could be promising or foreboding. We, of course, contributed to that and will receive part of the blame if there is a significant crackdown on or co-option of the practice. However, nothing can erase what the LCC accomplished from 2008-2011. This Golden Age of London urban exploration will always be the legacy of our crew and I still feel privileged to have experienced it. What other legacies we may have left behind, what accomplishments we may never speak of, I will leave to your imagination, and what tales of urban exploration future generations will tell, we leave to them.



## Epilogue

In 2012, Transport for London issued an antisocial-behaviour order (ASBO) against the “Aldwych Four”, as the press came to call them.<sup>69</sup> Incredibly, the ASBO stipulates that the explorers, who already accepted cautions from the British Transport Police, will not be able to speak to each other, speak to anyone else about urban exploration (never defined in the ASBO), undertaking exploration or carry any equipment that could be used for exploration after dark. The order would last for 10 years. In February 2012, “Gary” made a deal with TfL to take a 2-year ASBO on those conditions. The other cases are ongoing. Separately, Patch was prosecuted in February for derailing the Mail Rail train. He received a 4-month custodial sentence suspended for 2 years, 60 hours of unpaid work, and £1000 in compensation to Royal Mail for property damage. In the midst of the various court proceedings, British Museum station was explored and the list completed.



Figure 199. The growth of an idea, London 2012, photo by author

<sup>69</sup> <http://www.guardian.co.uk/uk/2012/feb/24/london-underground-explorers-security-services> (accessed 24th February 2012).



Figure 200. Simplicity, photo by Silent Motion

### Work Cited

- Adey, P. (2009) Facing Airport Security: Affect, Biopolitics, and the Preemptive Securitisation of the Mobile Body. *Environment and Planning D: Society and Space*, 27, 274-295.
- Affleck, B. (2010) *The Town*. Los Angeles, California: Warner Bros.
- Agar, M. (1973) *Ripping and Running: A Formal Ethnography of the Urban Heroin Addict*, London, Seminar Press.
- Aitken, S. C. (1994) *Putting Children in Their Place*, Washington, DC, Association of American Geographers.
- Alighieri, D. (1920) *The Inferno of Dante*, Boston, Massachusetts Harvard College Library.
- Amin, A. & Thrift, N. (2002) *Cities: Reimagining the Urban*, Cambridge, United Kingdom, Polity Press.
- Anderson, E. (1976) *Our Place on the Corner*, Chicago, Illinois, University of Chicago Press.
- Anderson, E. (2009a) Urban Ethnography: Its Traditions and Its Future. *Ethnography (special double issue)*, 10, 371-568.
- Anderson, E. (2009b) Urban Ethnography: Its Traditions and Its Future (Introduction). *Ethnography*, 10, 371-417.
- Anton, M., Garrett, B. L., Hess, A., Miles, E. & Moreau, T. (2011) London's Olympic Waterscape: Capturing Transition. *International Journal of Heritage Studies*.
- Applebaum, H. A. (1981) *Royal Blue: The Culture of Construction Workers*, New York, Holt, Rinehart and Winston.
- Arthur, C. & Halliday, J. (2011) Lulzsec Leak: Is This the Beginning of the End for the Hackers? *The Guardian*.
- Barbash, I. & Taylor, L. (1997) *Cross Cultural Filmmaking: A Handbook for Making Documentaries and Ethnographic Films and Video*, Berkeley, California, University of California Press.
- Barnard, A. (2004) The Legacy of the Situationist International: The Production of Situations of Creative Resistance. *Capital & Class*, 28, 103-124.
- Basso, K. (1996) Wisdom Sits in Places: Notes on a Western Apache Landscape. In: Feld, S. & Basso, K. (eds.) *Senses of Place*. Sante Fe: School of American Research Press.
- Baudrillard, J. (1998) *The Consumer Society: Myths and Structures*, Thousand Oaks, California, Sage Publications.
- Behar, R. (1997) *The Vulnerable Observer: Anthropology That Breaks Your Heart*, Boston, Massachusetts, Beacon Press.
- Bender, B. (1998) *Stonehenge: Making Space*, Oxford, Berg.
- Benjamin, W. (1998) *The Origin of German Tragic Drama*, London, Verso.
- Benjamin, W. (1999) *The Arcades Project*, Cambridge, Massachusetts, Harvard University Press.
- Bennett, J. (2004) The Force of Things: Steps toward an Ecology of Matter. *Political Theory*, 32, 347-372.
- Bennett, J. (2010) *Vibrant Matter: A Political Ecology of Things*, Duke University Press.
- Bennett, K. & Shurmer-Smith, P. (2001) Writing Conversation. In: Limb, M. & Dwyer, C. (eds.) *Qualitative Methodologies for Geographers: Issues and Debates*. London: Arnold.
- Bennett, L. (2011) Bunkerology—a Case Study in the Theory and Practice of Urban Exploration. *Environment and Planning D: Society and Space*, 29, 421-434.

- Berg, L. (2011) Geographies of Identity I: Geography - (Neo)Liberalism - White Supremacy. *Progress in Human Geography*, Online First.
- Bey, H. (1985) *T.A.Z.: The Temporary Autonomous Zone*, Williamsburg, Brooklyn, Autonomedia.
- Binnie, J. (1992) Fucking among the Ruins: Postmodern Sex in Postindustrial Places. *Sexuality and space network conference on lesbian and gay geographies?* University College London.
- Bonnett, A. (1989) Situationism, Geography, and Poststructuralism. *Environment and Planning D: Society and Space*, 7, 131-146.
- Bonnett, A. (1993) *Radicalism, Anti-Racism, and Representation*, London ; New York, Routledge.
- Bonnett, A. (1996a) Editorial. *Transgressions: a journal of urban exploration*, 2/3, 7-10.
- Bonnett, A. (1996b) The Transgressive Geographies of Daily Life. *Transgressions*, 2/3, 20-37.
- Bonnett, A. (2009) The Dilemmas of Radical Nostalgia in British Psychogeography. *Theory, Culture and Society*, 26, 45-70.
- Borden, I. (2001) *Skateboarding, Space and the City: Architecture and the Body*, Oxford, United Kingdom, Berg.
- Borges, J. L. (1971) *The Adelp and Other Stories: 1933-1969*, New York, Bantam.
- Bourdieu, P. & Lamaison, P. (1986) From Rules to Strategies: An Interview with Pierre Bourdieu. *Cultural Anthropology*, 1, 110-120.
- Breton, A. (1978) *What Is Surrealism? Selected Writings.*, New York, NY, Pathfinder press.
- Brick, G. (2009) *Subterranean Twin Cities*, Minneapolis, Minnesota, University of Minnesota Press.
- Buchanan, I. (1997) The Problem of the Body in Deleuze and Guattari, or, What Can a Body Do? *Body & Society*, 3, 73-91.
- Buchanan, I. & Lambert, G. (2011) *Deleuze and Space*, Edinburgh, UK, Edinburgh University Press.
- Buck-Morris, S. (1991) *The Dialectics of Seeing: Walter Benjamin and the Arcades Project*, Cambridge, Massachusetts, MIT Press.
- Bunge, W. (1969) The First Years of the Detroit Geographical Expedition: A Personal Report Detroit, Michigan: Society for human exploration.
- Burton, J. F., Farrell, M. M., Lord, F. B. & Lord, R. W. (1999) Confinement and Ethnicity: An Overview of World War II Japanese American Relocation Sites. National Park Service, US Department of the Interior.
- Butler, T. (2003) Living in the Bubble: Gentrification and Its Others in North London. *Urban Studies*, 40, 2469-2486.
- Cahill, L. & Mcgaugh, J. (1998) Mechanisms of Emotional Arousal and Lasting Declarative Memory *Trends Neurosci*, 21, 294-299.
- Caillois, R. (1961) *Man, Play and Games*, New York, Free Press.
- Calame, J. & Charlesworth, E. R. (2009) *Divided Cities: Belfast, Beirut, Jerusalem, Mostar, and Nicosia*, Philadelphia, University of Pennsylvania Press.
- Camus, A. (1991) *The Plague*, New York, Vintage.
- Cant, S. (2003) 'The Tug of Danger with the Magnetism of Mystery' Descents into 'the Comprehensive Poetic-Sensuous Appeal of Caves'. *Tourist Studies*, 3, 67-81.
- Cant, S. & Sharma, U. (1998) Reflexive Ethnography. *The Sociological Review*, 244-263.

- Cassell, J. (1988) The Relationship of the Observer and Observed When Studying Up. *Studies in Qualitative Methodology*, 1, 89-108.
- Christie, A. (1992) *By the Pricking of My Thumbs*, New York, Harper Prism.
- Cloke, P. & Perkins, H. J. (1998) Cracking the Cannon with the Awesome Foursome: Representations of Adventure Tourism in New Zealand. *Environment and Planning D: Society and Space*, 185-218.
- Coleman, E. G. & Golub, A. (2008) Hacker Practice: Moral Genres and the Cultural Articulation of Liberalism. *Anthropological Theory*, 8, 255-277.
- Committee, I. (2009) *The Coming Insurrection*, Los Angeles, California, Semiotext(e).
- Conradson, D. (2007) Experiential Economies of Stillness: The Place of Retreat in Contemporary Britain. In: Allison, W. (ed.) *Therapeutic Landscapes: Geographies of Health*. Aldershot: Ashgate.
- Cooley, C. H. (1909) *Social Organization*, New York, Scribner's.
- Corbin, A. (1986) *Le Miasme Et La Jonquille*, Paris, Flammarion.
- Corbusier, L. (1987) *The City of to-Morrow and Its Planning*, Mineola, New York, Dover Publications.
- Cosgrove, D. (2005) Contested Global Visions: One-World, Whole-Earth, and the Apollo Space Photographs. *Annals of the Association of American Geographers*, 84, 270-294.
- Costo, R. & Costo, J. H. (1987) *Missions of California: A Legacy of Genocide*, Riverside, California, Indian History Press.
- Cowie, J. & Heathcott, J. (2003) *Beyond the Ruins: The Meanings of Deindustrialization*, Ithaca, Cornell University Press.
- Crang, M. (1996) Magic Kingdom or a Quixotic Quest for Authenticity? *Annals of Tourism Research*, 23, 415-431.
- Crang, M. (1998) *Cultural Geography (Routledge Contemporary Human Geography)*, New York, NY, Routledge.
- Crang, M. & Cook, I. (2007) *Doing Ethnographies*, London, Sage Publications.
- Crang, M. & Travlou, P. S. (2001) The City and Topologies of Memory. *Environment and Planning D: Society and Space*, 19, 161-177.
- Cresswell, T. (1993) Mobility as Resistance: A Geographical Reading of Kerouac's 'on the Road'. *Transactions of the Institute of British Geographers*, 18, 249-262.
- Cresswell, T. (1996) *In Place/out of Place: Geography, Ideology, and Transgression*, Minneapolis, University of Minnesota Press.
- Cresswell, T. (1999) Embodiment, Power and the Politics of Mobility: The Case of Female Tramps and Hobos. *Transactions of the Institute of British Geographers*, 24, 175-192.
- Cresswell, T. (2004) *Place: A Short Introduction*, Oxford, Blackwell.
- Cresswell, T. (2010) Towards a Politics of Mobility. *Environment and Planning D: Society and Space*, 28, 17-31.
- Crick, M. (1976) *Explorations in Language and Meaning*, London, Malaby Press.
- Cronon, W. (1995) The Trouble with Wilderness or, Getting Back to the Wrong Nature. In: Cronon, W. (ed.) *Uncommon Ground: Toward Reinventing Nature*. New York: W.W. Norton & Co.
- Crouch, D. (2003) Spacing, Performing, and Becoming: Tangles in the Mundane. *Environment and Planning A* 35, 1945-1960.
- Csikszentmihalyi, M. (1981) Leisure and Socialization. *Social Forces*, 60, 332-340.

- Curti, G. H. (2008) The Ghost in the City and a Landscape of Life: A Reading of Difference in Shirow and Oshii's Ghost in the Shell. *Environment and Planning D: Society and Space*, 26, 87-106.
- Davidson, J., Bondi, L. & Smith, M. (2005) *Emotional Geographies*, Aldershot, Ashgate.
- Davidson, J. & Milligan, C. (2004) Embodying Emotion Sensing Space: Introducing Emotional Geographies. *Social & Cultural Geography*, 5, 523-532.
- Davis, M. (2002) *Dead Cities and Other Tales*, New York, The New Press.
- De Certeau, M. (1984) *The Practice of Everyday Life*, Berkeley, California, University of California Press.
- Debord, G. (1981) Report on the Construction of Situations and on the International Situationsit Tedancy's Conditions of Orginzation and Action. In: Knabb, K. (ed.) *Situationist Internation Anthology*. Berkeley: Bureau of Public Secrets.
- Debord, G. (2006a) Introduction to a Critique of Urban Geography. In: Knabb, K. (ed.) *Situationis International Anthology*. Paris: Bureau of Public Secrets.
- Debord, G. (2006b) *The Society of the Spectacle*, London, Rebel Press.
- Debord, G. (2006c) Théorie De La Dérive. In: Knabb, K. (ed.) *Situationist International Anthology*. Paris: Bureau of Public Secrets.
- Degen, M. & Desilvey, C. (2008) Experiencing Visualities in Designed Urban Environments: Learning from Milton Keynes. *Environment and Planning A*, 40, 1901-1920.
- Deleuze, G. (1990) Society of Control. *L'autre journal*, 1.
- Deleuze, G. & Guattari, F. (1988) *A Thousand Plateaus: Capitalism and Schizophrenia*, London, Athlone Press.
- Delyser, D. (1999) Authenticity on the Ground: Engaging the Past in a California Ghost Town. *Annals of the Association of American Geographers*, 89, 602-632.
- Delyser, D. (2004) Recovering Social Memories from the Past: The 1884 Novel *Ramona* and Tourist Practices in Turn-of-the-Century Southern California. *Social & Cultural Geography*, 5, 483-496.
- Derrida, J. (1981) *Writing and Difference*, Oxford, Routledge & Kegan Paul PLC.
- Derrida, J. (1994) *Spectres of Marx*, London, Routledge.
- Desilvey, C. (2006) Observed Decay: Telling Stories with Mutable Things. *Journal of Material Culture*, 11, 318-338.
- Desilvey, C. (2007a) Art and Archive: Memory-Work on a Montana Homestead. *Journal of Historical Geography*, 33, 878-900.
- Desilvey, C. (2007b) Salvage Memory: Constellating Material Histories on a Hardscrabble Homestead. *Cultural Geographies*, 14, 401-424.
- Desilvey, C. (2011) Making Sense of Transience: An Anticipatory History. *Cultural Geographies*, Online First.
- Devereaux, L. & Hillman, R. (1995) *Fields of Vision: Essays in Film Studies, Visual Anthropology, and Photography*, Berkeley, University of California Press.
- Deyo, L. B. & Leibowitz, D. (2003) *Invisible Frontier: Exploring the Tunnels, Ruins, and Rooftops of Hidden New York*, New York, Three Rivers Press.
- Dickens, C. (1861) All the Year Round. *All the year round*. London.
- Dickens, L. (2008a) "Finders Keepers": Performing the Street, the Gallery and the Spaces in-Between *Liminalities: A Journal of Performance Studies*, 4, 1-30.
- Dickens, L. (2008b) Placing Post-Graffiti: The Journey of the Peckham Rock. *Cultural Geographies*, 15, 471-496.

- Dickens, L. (2010) Pictures on Walls? Producing, Pricing and Collecting the Street Art Screen Print. *City: analysis of urban trends, culture, theory, policy, action*, 14, 63-81.
- Dixon, D. P. & Straughan, E. R. (2010) Geographies of Touch/Touched by Geography. *Geography Compass*, 4, 449-459.
- Dobraszczyk, P. (2005) Sewers, Wood Engraving and the Sublime: Picturing London's Main Drainage System in the Illustrated London News, 1859–62. *Victorian Periodicals Review*, 38, 349-378.
- Dobraszczyk, P. (2010) Petrified Ruin: Chernobyl, Pripjat and the Death of the City. *City: analysis of urban trends, culture, theory, policy, action*, 14, 370-389.
- Doel, M. A. (2009) Just Excess. The Joy of Waste. *Environment and Planning D: Society and Space*, 27, 956-965.
- Douglas-Jones, I. (2009) *Urban Exploration and the Search for the Sublime*. B.A., Royal College of Art.
- Driver, F. (2003) On Geography as a Visual Discipline. *Antipode*, 35, 227-231.
- Driver, F. & Jones, L. (2009) *Hidden Histories of Exploration*, London, Royal Geographical Society (with IBG).
- Edensor, T. (1998) The Culture of the Indian Street. In: Fyfe, N. R. (ed.) *Images of the Street: Planning, Identity, and Control in Public Space*. London: Routledge.
- Edensor, T. (1999) Staging Tourism Tourists as Performers. *Annals of Tourism Research*, 27, 322-344.
- Edensor, T. (2002) *National Identity, Popular Culture and Everyday Life*, New York, NY ; Oxford, England, Berg Publishers.
- Edensor, T. (2005a) The Ghosts of Industrial Ruins: Ordering and Disordering Memory in Excessive Space. *Environment and Planning D: Society and Space*, 23, 829-849.
- Edensor, T. (2005b) *Industrial Ruins: Space, Aesthetics, and Materiality*, Oxford, United Kingdom, Berg Publishers.
- Edensor, T. (2005c) Waste Matter - the Debris of Industrial Ruins and the Disordering of the Material World. *Journal of Material Culture*, 10, 311-332.
- Edensor, T. (2007) Sensing the Ruin *Senses and Society*, 2, 217–232.
- Edensor, T. (2008) Mundane Hauntings: Commuting through the Phantasmagoric Working-Class Spaces of Manchester, England. *Cultural Geographies*, 15, 313-333.
- Edensor, T., Christie, C. & Lloyd, B. (2008) Obliterating Informal Space: The London Olympics and the Lea Valley: A Photo Essay. *Space and Culture*, 11, 285-293.
- El Guindi, F. (2004) *Visual Anthropology: Essential Method and Theory*, Walnut Creek, California, AltaMira Press.
- Elliot, C. W. (1937) *Edmund Burke: On Taste, on the Sublime and Beautiful, Reflections on the French Revolution, a Letter to a Noble Lord, with Introduction and Notes*, New York, P. F. Collier
- Ellis, C. & Bochner, A. (2005) Autoethnography, Personal Narrative, Reflexivity: Researcher as Subject. In: Denzin, N. & Lincoln, Y. (eds.) *The Handbook of Qualitative Research (2nd Ed.)*. Newbury Park: Sage.
- Erikson, K. T. (1976) *Everything in Its Path: Destruction of Community in the Buffalo Creek Flood*, New York, Simon & Schuster.
- Fantz, A. & Shubert, A. (2010) Wikileaks 'Anonymous' Hackers: 'We Will Fight'. CNN.

- Feld, S. & Basso, K. (1996) *Senses of Place*, Santa Fe, New Mexico, School of American Research Press (Distributed by the University of Washington Press).
- Fenton, J. (2005) Space, Chance, Time: Walking Backwards through the Hours on the Left and Right Banks of Paris. *cult geogr*, 12, 412-428.
- Fletcher, R. (2008) Living on the Edge. The Appeal of Risk Sports for the Professional Middle Class. *Sociology of Sport Journal*, 25, 310-330.
- Foucault, M. & Rabinow, P. (1984) *The Foucault Reader*, London, Vintage.
- Fox, N. J. (2002) Refracting 'Health': Deleuze, Guattari and Body-Self. *Health: An Interdisciplinary Journal for the Social Study of Health, Illness and Medicine*, 6, 347-363.
- Frantz, J. (2007) Using Participatory Video to Enrich Planning Process. *Planning Theory & Practice*, 8, 103-107.
- Frers, L. & Meier, L. (2007) *Encountering Urban Places: Visual and Material Performances in the City*, Aldershot, England ; Burlington, VT, Ashgate.
- Frykman, J. (1994) On the Move: The Struggle for the Body in Sweden. In: Seremetakis, C. N. (ed.) *The Senses Still: Perception and Memory as Material Culture in Modernity*. Chicago: University of Chicago Press.
- Fuchs, P. (1988) Ethnographic Film in Germany: An Introduction. *Visual Anthropology*, 1, 217-223.
- Fukuyama, F. (1992) *The End of History and the Last Man* London, Penguin.
- Fullagar, S. (2001) Encountering Otherness: Embodied Affect in Alphonso Lingis's Travel Writing. *Tourist Studies*, 1, 171-183.
- Game, A. (1991) *Undoing the Social: Towards a Deconstructive Sociology*, Maidenhead, Berkshire, Open University Press.
- Gandy, M. (1999) The Paris Sewers and the Rationalization of Urban Space *Transactions of the Institute of British Geographers*, 24, 23-44.
- Gandy, M. (2004) Rethinking Urban Metabolism: Water, Space and the Modern City. *City: analysis of urban trends, culture, theory, policy, action*, 8, 363-379.
- Gandy, M. (2005) Cyborg Urbanization: Complexity and Monstrosity in the Contemporary City *International Journal of Urban and Regional Research*, 29, 26-49.
- Gandy, M. (2008) Landscapes of Disaster: Water, Modernity, and Urban Fragmentation in Mumbai. *Environment and Planning A*, 40, 108-130.
- Garrett, B. L. (2009) Drowned Memories: The Submerged Places of the Winnemem Wintu. *Archaeologies: Journal of the World Archaeological Congress*, 6, 346-371.
- Garrett, B. L. (2010a) Urban Explorers: Quests for Myth, Mystery and Meaning. *Geography Compass*, 4, 1448-1461.
- Garrett, B. L. (2010b) Videographic Geographies: Using Digital Video for Geographic Research. *Progress in Human Geography*, 35, 521-541.
- Garrett, B. L. (2011a) Assaying History: Creating Temporal Junctions through Urban Exploration. *Environment and Planning D: Society and Space*, 29, 1048-1067.
- Garrett, B. L. (2011b) Cracking the Paris Carrières: Corporal Terror and Illicit Encounter under the City of Light. *Acme: An International E-Journal for Critical Geographies*, 10, 269-277.
- Garrett, B. L. (2011c) Undertaking Recreational Trespass: An Ethnography of Urban Exploration. *Transactions of the Institute of British Geographers*.
- Geertz, C. (1983) *Local Knowledge : Further Essays in Interpretive Anthropology*, New York, Basic Books.



- Geoghegan, H. (2012) In the Company of Kindred Spirits: Collective Enthusiasm in Groups and Societies. *Area*, (In press).
- Godwin, R. (2010) Secrets of an Urbex Mission. *Evening Standard*, 15th March 2010.
- Goethe, J. W. V. (1909) *Goethe's Faust*, London, Cassell and Company Ltd
- Graham, S. (2000) City a-Z. In: Thrift, N. & Pile, S. (eds.). London: Routledge.
- Graham, S. & Marvin, S. (2001) *Splintering Urbanism: Networked Infrastructures, Technological Mobilities and the Urban Condition*, London, Routledge.
- Graham, S. & Thrift, N. (2007) Out of Order: Understanding Repair and Maintenance. *Theory, Culture & Society*, 24, 1-25.
- Gross, D. (2000) *Lost Time: On Remembering and Forgetting in Late Modern Culture*, Amherst, MA, University of Massachusetts Press.
- Grosz, E. (1998) Bodies-Cities. In: Pile, S. & Nast, H. (eds.) *Places through the Body*. London: Routledge.
- Gurstelle, W. (2009) Take Smart Risks. *Wired*. New York, New York: Conde Nast.
- Handler, R. & Saxton, W. (2009) Dyssimulation: Reflexivity, Narrative, and the Quest for Authenticity in "Living History". *Cultural Anthropology*, 3, 242-260.
- Haraway, D. J. (1991) *Simians, Cyborgs and Women : The Reinvention of Nature*, London, Routledge.
- Harris, A. (2011) Art and Gentrification: Pursuing the Urban Pastoral in Hoxton, London. *Transactions of the Institute of British Geographers*, no-no.
- Harris, J. (2010) *Urban Exploration: The Search for Memory in Forgotten Place*. B.A., University of Manchester.
- Harris, M. (1976) History and Significance of the Emic/Etic Distinction. *Annual Review of Anthropology*, 5, 329-350.
- Harrison, P. (2000) Making Sense: Embodiment and the Sensibilities of the Everyday. *Environment and Planning D: Society and Space*, 18, 497-517.
- Hastrup, K. (1992) Anthropological Visions: Some Notes on Visual and Textual Authority. In: Crawford, P. I. & Turton, D. (eds.) *Film as Ethnography*. Manchester: Manchester University Press in association with the Granada Centre for Visual Anthropology.
- Haushofer, K. (1934) *Weltpolitik Von Heute*, Berlin, Zeitgeschichte.
- Hawkins, G. & Muecke, S. (2003) *Culture and Waste*, Devon, United Kingdom, Rowman & Littlefield Publishers.
- Hayles, N. K. (1999) *How We Became Posthuman : Virtual Bodies in Cybernetics, Literature, and Informatics*, Chicago, Ill., University of Chicago Press.
- Heider, K. G. (1976) *Ethnographic Film*, Austin, Texas, University of Texas Press.
- Hell, J. & Schönle, A. (2010) *Ruins of Modernity*, London, Duke University Press.
- Herbert, S. (2000) For Ethnography. *Progress in Human Geography*, 24, 550-568.
- Hetherington, K. (2003) Spatial Textures: Place, Touch, and Praesentia. *Environment and Planning A*, 35, 1933-1944.
- High, S. & Lewis, D. W. (2007) *Corporate Wasteland*, Ithica, New York, Cornell University Press.
- Hill, D., Panetta, F. & Levene, D. (2009) Olympic Stories: Hackney Wick *The Guardian*, 23rd November 2009.
- Høeg, P. (2005) *Miss Smilla's Feeling for Snow*, London, Vintage Books.
- Hollingshead, J. (2009 [1862]) *Underground London*, London, Kessinger Publishing.
- Holloway, J. & Kneale, J. (2008) Locating Haunting: A Ghost-Hunter's Guide. *Cultural Geographies*, 15, 297-312.

- Holtorf, C. (2005) *From Stonehenge to Las Vegas*, Walnut Creek, California, Altamira Press.
- Howes, D. (2005) Architecture of the Senses. *Sense of the City Exhibition Catalogue*. Montreal: Canadian Centre for Architecture.
- Hubbard, P. (2005) The Geographies of 'Going Out': Emotion and Embodiment in the Evening Economy. In: Davidson, J., Bondi, L. & Smith, M. (eds.) *Emotional Geographies*. Aldershot: Ashgate.
- Hudson, J. (2010) Urban Subversions: Creative (Re)Appropriations within the Marginal Spaces of the City *RGS-IBG Annual Conference*. London, England.
- Hugo, V. (1987) *Les Misérables*, New York, Signet Classics.
- Huizinga, J. (1950) *Homoludens: A Study of the Play Element in Culture*, Boston, Beacon.
- Huysen, A. (2003) *Present Pasts: Urban Palimpsests and the Politics of Memory*, Stanford, California, Stanford University Press.
- Huysen, A. (2010) Authentic Ruins. In: Hell, J. & Schönle, A. (eds.) *Ruins of Modernity*. London: Duke University Press.
- Ingham, J., Purvis, M. & Clark, D. B. (2007) Hearing Places, Making Spaces: Sonorous Geographies, Ephemeral Rhythms, and the Blackburn Warehouse Parties. *Environment and Planning D: Society and Space*, 17, 283-305.
- Jackson, J. B. (1980) *The Necessity for Ruins, and Other Topics*, Amherst, Massachusetts, University of Massachusetts Press.
- James, H. (1968 [1909]) *Italian Hours*, New York, Horizon Press.
- Jay, M. (1993) Ideology and Ocularcentrism: Is There Anything Behind the Mirror's Tain? In: Jay, M. (ed.) *Force Fields: Between Intellectual History and Cultural Critique*. London: Routledge.
- Jefferies, R. (2010 [1885]) *After London*, London, Forgotten Books.
- Johansson, L., Knippel, V., De Waal, D. & Nyamachumbe, F. (1999) Questions and Answers About Participatory Video. *Forests, Trees and People Newsletter*, 40/41, 35-40.
- Johnston, R. J. (2000) *The Dictionary of Human Geography*, Oxford, United Kingdom, Blackwell Publishers.
- Jones, O. (2001) Before the Dark of Reason': Some Ethical and Epistemological Considerations on the Otherness of Children. *Ethics, Place and Environment*, 4.
- Jonker, J. & Till, K. E. (2009) Mapping and Excavating Spectral Traces in Post-Apartheid Cape Town. *Memory Studies*, 2, 303-335.
- Josephides, L. (1997) Representing the Anthropologist's Predicament. In: James, W., Hockney, J. & Dawson, A. (eds.) *After Writing Culture: Epistemology and Praxis in Contemporary Anthropology*. London: Routledge.
- Joyce, J. (1990) *Ulysses*, London, Vintage.
- Juris, J. (2010) Practicing Militant Ethnography within Movements against Corporate Globalization. 1-7.
- Kaika, M. & Swyngedouw, E. (2000) Fetishizing the Modern City: The Phantasmagoria of Urban Technological Networks. *International Journal of Urban and Regional Research*, 24, 120-138.
- Katz, C. (2004) *Growing up Global: Economic Restructuring and Children's Everyday Lives*, Minneapolis, Minnesota, University of Minnesota Press.
- Katz, J. (1988) *Seductions of Crime: Moral and Sensual Attractions in Doing Evil*, New York, Basic Books.
- Kindon, S. (2003) Participatory Video in Geographic Research: A Feminist Practice of Looking? *Area*, 35, 142-153.

- King, S. (1986) *The Stand*, New York, Signet.
- Klausner, S. Z. (1968) The Intermingling of Pain and Pleasure: The Stress Seeking Personality in Its Social Context. In: Klausner, S. Z. (ed.) *Why Men Take Chances*. Garden City, N.Y: Anchor.
- Klein, N. (2000) *No Logo: Taking Aim at the Brand Bullies*, London, HarperCollins.
- Knabb, K. (1981) *Situationist International: Anthology*, California, Bureau of Public Secrets.
- Kristeva, J. (1982) *The Powers of Horror: An Essay on Abjection*, New York, Columbia University Press.
- Kunstler, J. H. (2008) *World Made by Hand*, New York, Atlantic Monthly Press.
- Kunthear, M. (2011) Families Face Grave Situation *Phnom Pehn Post*.
- Lasch, C. (1978) *The Culture of Narcissism*, New York, Norton.
- Laurier, E. (2009) Editing Experience: Sharing Adventures through Home Movies. *Assembling the Line*, 1-19.
- Laurier, E. (2010) An Ethnography of a Neighbourhood Café: Informality, Table Arrangements and Background Noise. *Journal of Mundane Behaviour*, 2, 195-323.
- Laurier, E. & Brown, B. (2011) The Reservations of the Editor: The Routine Work of Showing and Knowing the Film in the Edit Suite. *Journal of Social Semiotics*, 21, 239-257.
- Laurier, E., Lorimer, H., Brown, B., Jones, O., Juhlin, O., Noble, A., Perry, M., Pica, D., Sormani, P., Strebel, I., Swan, L., Taylor, A. S., Watts, L. & Weilenmann, A. (2008) Driving and Passengering: Notes on the Ordinary Organisation of Car Travel. *Mobilities*, 3, 1-23.
- Leary, J. P. (2011) Detroitism. *Guernica*. Delaware: Guernica Magazine.
- Lees, C. A. & Overing, G. R. (2006) *A Place to Believe In: Locating Medieval Landscapes*, University Park, Pennsylvania, Pennsylvania State University Press.
- Lefebvre, H. (1991) *The Production of Space*, London, Wiley-Blackwell.
- Lefebvre, H. (2004) *Rhythmanalysis: Space, Time, and Everyday Life*, London, Continuum.
- Legg, S. (2004) Memory and Nostalgia. *Cultural Geographies*, 11, 99-107.
- Legg, S. (2007) Reviewing Geographies of Memory/Forgetting. *Environment and Planning A*, 39, 456-466.
- Lewis, N. (2000) The Climbing Body, Nature and the Experience of Modernity. *Body & Society*, 6, 58-80.
- Ley, D. (1974) *The Black Inner City as Frontier Outpost: Images and Behavior of a Philadelphia Neighborhood*, Washington D.C., Association of American Geographers.
- Lipman, C. (2004) *Trespassing in the Ruins: Urban Exploration at the Crx*. M.A., Royal Holloway, University of London.
- Lipman, C. (2009) The Domestic Uncanny: Co-Habiting with Ghosts. *London Group of Historical Geographers Seminar Series*. University of London.
- Lippard, L. R. (1997) *The Lure of the Local: Senses of Place in a Multicentered Society*, New York, New Press.
- Liz & Ninjalicious (2003) Suspicious Behaviour. *Infiltration: The Zine About Going Places You're Not Supposed To Go*. Toronto, Canada: Infilpress.
- Loftus, A. (2009) Intervening in the Environment of the Everyday. *Geoforum*, 40, 326-334.
- Lorimer, H. (2003) Telling Small Stories: Spaces of Knowledge and the Practice of Geography *Transactions of the Institute of British Geographers*, 28, 197-217.

- Lorimer, H. (2005) Cultural Geography: The Busyness of Being 'More-Than-Representational'. *Progress in Human Geography*, 29, 83-94.
- Lorimer, H. (2007) Cultural Geography: Worldly Shapes, Differently Arranged. *Progress in Human Geography*, 31, 89-100.
- Lorimer, H. (2008) Cultural Geography: Non-Representational Conditions and Concerns. *Progress in Human Geography*, 32, 551-559.
- Lowenthal, D. (1985) *The Past Is a Foreign Country*, Cambridge, United Kingdom, Cambridge University Press.
- Lowenthal, D. (1998) *The Heritage Crusade and the Spoils of History*, Cambridge, United Kingdom, Cambridge University Press.
- Löwgren, J. (2000) Origins of Hacker Culture(S). *Hacker culture(s)* [Online].
- Luckhurst, R. (1997) *The Angle between Two Walls: The Fiction of J.G. Ballard*, Liverpool, Liverpool University Press.
- Lusito, E. & Conte, F. (2009) *After the Wall: Traces of the Soviet Empire*, Stockport, England, Dewey Lewis.
- Lynden, J. (2011) Into the Tunnels: Exploring the Underside of Nyc. United States of America: National Public Radio (NPR).
- Lyng, S. (1990a) Edgework: A Social Psychological Analysis of Voluntary Risk Taking. *The American Journal of Sociology*, 95, 851-886.
- Lyng, S. (1990b) *A Social Psychological Analysis of Voluntary Risk Taking*, London, Routledge.
- Lyng, S. (2004) Crime, Edgework and Corporeal Transaction. *Political Theory*, 8, 359-375.
- Macaulay, R. D. (1966) *Pleasure of Ruins*, New York, NY, Walker and Company.
- Macpherson, H. (2005) Landscape's Ocular-Centrism - and Beyond? In: Tress, B., Tress, G., Fry, G. & Opdam, P. (eds.) *From Landscape Research to Landscape Planning: Aspects of Integration, Education and Application (Wageningen Ur Frontis Series)*. New York, New York: Springer.
- Maddern, J. F. (2008) Spectres of Migration and the Ghosts of Ellis Island. *Cultural Geographies*, 15, 359-381.
- Maddern, J. F. & Adey, P. (2008) Editorial: Spectro-Geographies. *Cultural Geographies*, 15, 291-295.
- Manauh, G. (2009) *The Bldg Blog Book*, San Francisco, Chronicle Books.
- Marcus, G. (2001) *Lipstick Traces: A Secret History of the Twentieth Century*, London, Faber and Faber.
- Martha, C. & Griffet, J. (2006) Le Base-Jump, Le Jeu Le Plus SéRieux Du Monde. *Ethnologie Francaise*, 36, 635-642.
- Maruani, T. & Amit-Cohen, I. (2007) Open Space Planning Models: A Review of Approaches and Methods. *Landscape and Urban Planning*, 81, 1-13.
- Massey, D. (1994) Global Sense of Place. *Space, Place and Gender*. Minneapolis: University of Minnesota Press.
- Massumi, B. (1992) *A User's Guide to Capitalism and Schizophrenia: Deviations from Deleuze and Guattari*, MIT Press, Cambridge, Mass.
- Massumi, B. (1997) Involutionary Afterword. *The Canadian Review of Comparative Literature* 24, 745 - 782.
- Massumi, B. (1996) The Evolutionary Alchemy of Reason. *Stelarc: The Evolutionary*. 5CYBERCONF.
- Mccarthy, C. (2006) *The Road*, New York, Knopf.
- Mcdowell, L. (1997) *Capital Culture: Gender at Work in the City*, London, Blackwell
- Mcdowell, L. (1998) Elites in the City of London: Some Methodological Considerations. *Environment and Planning A*.

- Mcrae, J. D. (2008) *Play City Life: Henri Lefebvre, Urban Exploration and Re-Imagined Possibilities for Urban Life* M.A., Queen's University, Canada.
- Mead, G. H. (1934) *Mind, Self, and Society*, Chicago, Illinois, University of Chicago Press.
- Merleau-Ponty, M. (1962) *Phenomenology of Perception*, London, Routledge.
- Meskill, L. (2002) Negative Heritage and Past Mastering in Archaeology. *Anthropological Quarterly*, 75, 557-574.
- Milkman, R. (1997) *Farwell to the Factory*, Berkeley, University of California Press.
- Miller, H. (1960) *The Wisdom of the Heart*, New York, New Directions
- Millington, N. (2010) *Post-Industrial Imaginaries: Nature, Representation, and Ruin in Detroit, Michigan*. M.A., University of Wisconsin - Madison.
- Mitchell, D. (2000) The Annihilation of Space by Law: The Roots and Implications of Anti-Homeless Laws in the United States. *Antipode*, 29, 303-335.
- Mitchell, W. J. (2003) *Me++: The Cyborg Self and the Networked City*, Cambridge, Massachusetts, MIT Press.
- Montesquieu, C. D. S. (1901) *Persian and Chinese Letters*, Washington D.C., M. Walter Dunne.
- Moss, P. & Dyck, I. (2003) Embodying Social Geography. In: Anderson, K., Domosh, M., Pile, S. & Thrift, N. (eds.) *Handbook of Cultural Geography*. Sage: London.
- Mould, O. (2009) Parkour, the City, the Event. *Environment and Planning D: Society and Space*, 27, 738-750.
- Mould, O. & Garrett, B. L. (Year) Published. Urban Subversions: Comptemporary Pasttimes in Global Cities. RGS-IBG Annual Conference, 2011 London, England.
- Nestor, J. (2007) The Art of Urban Exploration. *The San Fransisco Gate* 19th August 2007.
- Neumann, M. (2002) Making the Scene: The Poetics and Performances of Displacement at the Grand Canyon. In: Coleman, S. & Crang, M. (eds.) *Tourism: Between Place and Performance*. Oxford: Berghahn Books.
- Nietzsche, F. W. (2006) *The Use and Abuse of History*, New York, New York, Cosimo Classics.
- Ninjalicious (1997) The End Is Nigh, but I'm Probing On. *Infiltration: The Zine About Going Places You're Not Supposed To Go*. Toronto: Infilpress.
- Ninjalicious (1999) On Viewing Holes. *Infiltration: The Zine About Going Places You're Not Supposed To Go*. Toronto: Infilpress.
- Ninjalicious (2005) *Access All Areas: A User's Guide to the Art of Urban Exploration*, Canada, Infilpress.
- Nissenbaum, H. (2004) Hackers and the Contested Ontology of Cyberspace. *Political Theory*, 6, 195-217.
- O'brien, M. (2007) *Beneath the Neon: Life and Death in the Tunnels of Las Vegas* Las Vegas, Nevada, Huntington Press.
- O'malley, P. & Mugford, S. (1995) Crime, Excitement and Modernity. In: Barak, G. (ed.) *Varieties of Criminology*. Westport, CT: Praeger.
- Olstead, R. (2011) Gender, Space and Fear: A Study of Women's Edgework. *Emotion, Space and Society*, 1-9.
- Osborn, L. (2011) Urban Explorers Enter London Landmarks. *Evening Standard*, 11 November.
- Paglen, T. (2006) Late September at an Undisclosed Location in the Nevada Desert. *Cultural Geographies*, 13, 293-300.
- Pain, R. & Smith, S. (2008) *Fear : Critical Geopolitics and Everyday Life*, Aldershot, Hants, England ; Burlington, VT, Ashgate.

- Paiva, T. & Manaugh, G. (2008) *Night Visions: The Art of Urban Exploration*, San Francisco, California, Chronicle Books.
- Parr, H. (2000) Interpreting the 'Hidden Social Geographies' of Mental Health: Ethnographies of Inclusion and Exclusion in Semi-Institutional Places. *Health & Place*, 6, 225-237.
- Payne, C. (2009) *Asylum: Inside the Closed World of State Mental Hospitals*, Cambridge, Massachusetts, MIT Press.
- Pearson, K. A. (2009) Life Becoming Body: On the 'Meaning' of Post Human Evolution. *Cultural Values*, 1, 219-240.
- Pearson, M. & Shanks, M. (2001) *Theatre/Archaeology*, London, Routledge.
- Peck, J. & Tickell, A. (2002) Neoliberalisation of the City. *Antipode*, 34, 380-404.
- Pedrazzi & Desrosiers-Lauzon (2011) Asphalt Bandits. Fear, Insecurity, and Uncertainty in the Latin American City. *Emotion, Space and Society*.
- Pensky, M. (2005) Memory, Catastrophe, Destruction. *City: analysis of urban trends, culture, theory, policy, action*, 9, 205-214.
- Pile, S. (2005) *Real Cities: Modernity, Space, and the Phantasmagorias of City Life*, London; Thousand Oaks, Calif., SAGE.
- Pile, S. & Thrift, N. (1995) Mapping the Subject. In: Pile, S. & Thrift, N. (eds.) *Mapping the Subject: Geographies of Cultural Transformation*. London: Routledge.
- Pinder, D. (2000) "Old Paris No More": Geographies of Spectacle and Anti-Spectacle. *Antipode*, 357-386.
- Pinder, D. (2005a) Arts of Urban Exploration. *Cultural Geographies*, 12, 383-411.
- Pinder, D. (2005b) *Visions of the City : Utopianism, Power and Politics in Twentieth-Century Urbanism*, Edinburgh, Edinburgh University Press.
- Pinder, D. (2008) Urban Interventions: Art, Politics and Pedagogy. *International Journal of Urban and Regional Research*, 32, 730-736.
- Pink, S. (2007) *Doing Visual Ethnography: Images, Media and Representation in Research*, Manchester, Manchester University Press in association with the Granada Centre for Visual Anthropology.
- Pink, S. (2008) An Urban Tour: The Sensory Sociality of Ethnographic Place-Making. *Ethnography*, 9, 175-196.
- Predator (ND) *Approach: A Sprawling Manifesto on the Art of Drain Exploring*.
- Pyke, D. L. (2005) *Subterranean Cities: The World beneath Paris and London, 1800-1945*, Ithica, Cornell University Press.
- Rapp, A. (2010) *The Esoteric City: Urban Exploration and the Reclamation of the Built Environment*. Master of Fine Arts in Design Criticism, New York School of Visual Arts.
- Raymond, E. S. (1996) *The New Hacker's Dictionary*, Cambridge, Massachusetts, MIT Press.
- Reed, C. (1949) *The Third Man*. United Kingdom: British Lion Film.
- Rendell, J. (2010) Space, Place, Site: Critical Spatial Practice. In: Cartiere, C. & Willis, S. (eds.) *Re/Placing Public Art*. Saarbrücken , Germany: VDM Verlag Dr. Müller.
- Reyes, P. (2008) Bleak Houses: Digging through the Ruins of the Mortgage Crisis. *Harper's Magazine*. New York, New York: The Harper's Magazine Foundation.
- Reynolds, A. (2002) *Robert Smithson: Learning from New Jersey and Elsewhere*, Cambridge, MA, MIT Press.
- Richmond, T. (1973) Sites and Soundings. *Guardian*, 28th August.
- Rogoff, I. (2000) *Terra Infirma: Geography's Visual Culture*, London, Routledge.

- Romanywg (2010) *Beauty in Decay*, Durham, United Kingdom, Carpet Bombing Culture.
- Roppo, E. (ND) *Interior Wilderness*, San Francisco, California Blurb.
- Rose, G. (2001) *Visual Methodologies: An Introduction to the Interpretation of Visual Materials*, Thousand Oaks, California, Sage.
- Rose, G. (2003) On the Need to Ask How, Exactly, Is Geography "Visual"? *Antipode*, 35, 212-221.
- Rosenberg, H. (1970) *Criticism-Action. Act and the Actor*. Chicago, Illinois: University of Chicago Press.
- Roth, M. (1997) Irresistible Decay: Ruins Reclaimed. In: Roth, M., Lyons, C. & Merewether, C. (eds.) *Irresistible Decay: Ruins Reclaimed*. Los Angeles: Getty Research Institute for the History of Art and the Humanities.
- Rouch, J. & Feld, S. (2003) *Cine-Ethnography (Visible Evidence)*, Minneapolis, University of Minnesota Press.
- Routledge, P. (2002) Travelling East as Walter Kurtz: Identity, Performance, and Collaboration in Goa, India. *Environment and Planning D: Society and Space*, 20, 477-498.
- Rowles, G. D. & Watkins, J. F. (1993) Elderly Migration and Development in Small Communities. *Growth and Change*, 24, 509-538.
- Sadler, S. (1998) *The Situationist City*, Cambridge, MA, Cambridge, MA.
- Salganik, M. J. & Heckathorn, D. D. (2004) Sampling and Estimation in Hidden Populations Using Respondant-Driven Sampling *Sociological Methodology*, 34, 1-48.
- Samuel, R. (1994) *Theatres of Memory*, London, Verso.
- Sandercock, L. (2003) Towards Cosmopolis: Utopia as Construction Site. In: Cambell, S. & Fainstein, S. F. (eds.) *Readings in Planning Theory*. London: Wiley-Blackwell.
- Sandercock, L. & Attili, G. (2010) Digital Ethnography as Planning Praxis: An Experiment with Film as Social Research, Community Engagement and Policy Dialogue. *Planning Theory & Practice*, 11, 23-45.
- Sartre, J. P. & Baldick, R. (2000) *Nausea*, London, Penguin.
- Sartre, J. P. & Baskin, W. (1967) *Of Human Freedom*, New York, Philosophical Library.
- Sartre, J. P. & Turner, C. (2009) A Fine Display of Capuchins. *Harper's Magazine*.
- Saville, S. J. (2008) Playing with Fear: Parkour and the Mobility of Emotion. *Social & Cultural Geography*, 9, 891-914.
- Schneider, D. M. (1980) *American Kinship: A Cultural Account*, Chicago, Illinois, University of Chicago Press.
- Scott, J. (1998) *Seeing Like a State: How Certain Schemes to Improve the Human Condition Have Failed*, London and New Haven, Yale University Press.
- Scott, M. (1993) Hacking the Material World. *Wired*. New York, New York: Condé Nast
- Sebald, W. G. & Hulse, M. (1998) *The Rings of Saturn*, New York, New Directions.
- Sennett, R. (1994) *Flesh and Stone*, London, Faber.
- Sennett, R. (2008) *Qaunt: The Public Realm*. *Richardsennett.com* [Online].
- Shatz, A. (2010) Desire Was Everywhere. *London Review of Books*, 32, 9-12.
- Shaw, J. & Robertson, C. (1997) *Participatory Video: A Practical Guide to Using Video Creatively in Group Development Work*, London, Routledge.
- Shea, N. (2011) Under Paris. *National Geographic*. Washington DC: National Geographic Magazine.

- Shields, R. (1999) *Lefebvre, Love, and Struggle: Spatial Dialectics*, London, Routledge.
- Sibley, D. (1981) *Outsiders in an Urban Society*, Hampshire, UK, Palgrave Macmillan.
- Simmel, G. (1995) The Metropolis and Mental Life. In: Kasinitz, P. (ed.) *Metropolis: Centre and Symbol of Our Times*. London: Macmillan.
- Smith, M. & Davidson, J. (2005) 'It Makes My Skin Crawl...': The Embodiment of Disgust in Phobias of 'Nature'. *Body and Society*, 12, 43-67.
- Smith, P. (2010) The Contemporary Dérive: A Partial Reviw of Issues Concerning the Contemporary Practice of Psychogeography. *Cultural Geographies*, 17.
- Sobchack, V. (2004) *Carnal Thoughts, Embodiment and Moving Image Culture*, Berkeley, California, University of California Press.
- Söderström, O. (2010) Redefining the Field: Auto-Ethnographic Field Notes. *Cultural Geographies*, 18, 115-118.
- Solis, J. (2007) *New York Underground: The Anatomy of a City*, New York, Routledge.
- Solnit, R. (2001) *Wanderlust: A History of Walking*, London, Verso.
- Sontag, S. (1965) The Imagination of Disaster. *Liquid Metal: The Science Fiction Film Reader*, October, 42-48.
- Sontag, S. (1977) Unguided Tour. *New Yorker*. New York, New York.
- Speer, A. (1970) *Inside the Third Reich*, London, United Kingdom, Simon & Schuster.
- Spinney, J. (2008) *Cycling the City: Movement, Meaning and Practice*. PhD, Royal Holloway, University of London.
- Spinney, J. (2010) Performing Resistance: Re-Reading Practices of Urban Cycling on London's South Bank. *RGS-IBG Annual International Conference*. London, England.
- Springgay, S. (2003) Cloth as Intercorporeality: Touch, Fantasy, and Performance and the Construction of Body Knowledge. *International Journal of Education & the Arts*, 4.
- Stanley, C. (1995) Teenage Kicks: Urban Narratives of Dissent Not Deviance. *Crime, Law & Social Change*, 23, 91-119.
- Stead, N. (2007) The Value of Ruins: Allegories of Destruction in Benjamin and Speer. *Form/Work: An Interdisciplinary Journal of the Built Environment*, 6, 51-64.
- Steinbeck, J. (1997) *Travels with Charley in Search of America*, New York, NY, Penguin Twentieth-Century Classics.
- Steinmetz, G. (2010) Colonial Meloncholy and Fordist Nostalgia: The Ruinscapes of Namibia and Detroit. In: Hell, J. & Schönle, A. (eds.) *Ruins of Modernity*. London: Duke University Press.
- Stevens, Q. (2007) *The Ludic City*, London, Routledge.
- Stewart, G. R. (2006 [1949]) *Eath Abides*, New York, Del Rey.
- Stewart, K. (2007) *Ordinary Affects*, Durham and London, Duke University Press.
- Stewart, K. (2011) Atmospheric Attunements. *Environment and Planning D: Society and Space*, Advanced Online Copy, 1-10.
- Stone, P. G. & Planel, P. G. (1999) *The Constructed Past : Experimental Archaeology, Education, and the Public*, London ; New York, Routledge.
- Strange, C. & Kempa, M. (2003) Shades of Dark Tourism: Alcatraz and Robben Island. *Annals of Tourism Research*, 30, 386-405.
- Straughan, E. R. (2011) Touched by Water: The Body in Scuba Diving. *Emotion, Space and Society*, Online First, 1-8.



- Svt (2010) Wikileaks Editor Julian Assange Interviewed on Censorship Sweden: Sveriges Television.
- Taylor, D. (2003) *The Archive and the Repertoire: Performing Cultural Memory in the Americas*, Durham, North Carolina, Duke University Press.
- Thompson, H. S. (1998) *Fear and Loathing in Las Vegas: A Savage Journey to the Heart of the American Dream*, London, Flamingo Modern Classics.
- Thompson, H. S. (2003) *The Great Shark Hunt: Strange Tales from a Strange Time*, New York, Simon & Schuster.
- Thrift, N. (2004) Envisioning Human Geography. In: Cloke, P., Crang, P. & Goodwin, M. (eds.). London: Arnold.
- Thrift, N. (2008) *Non-Representational Theory: Space, Politics, Affect*, New York, Routledge.
- Till, K. E. (1999) Staging the Past: Landscape Designs, Cultural Identity and Erinnerungspolitik at Berlin's Neue Wache. *Cultural Geographies*, 6, 251-283.
- Toth, J. (1993) *The Mole People: Life in the Tunnels beneath New York City*, Chicago, Illinois, Chicago Review Press.
- Townsend, M. (2010) Return of Underground Rave Culture Is Fuelled by the Recession and Facebook. *The Guardian*, 7th November.
- Trevelyan, G. M. (1949) An Autobiography of an Historian. *An Autobiography & Other Essays*. London: Longmans, Green & Co.
- Trigg, D. (2005) Ninjalicious 1973-2005 *Side Effects* [Online].
- Trigg, D. (2006) *The Aesthetics of Decay: Nothingness, Nostalgia and the Absence of Reason*, New York, Peter Lang.
- Tuan, Y.-F. (1979) *Landscapes of Fear*, New York, Pantheon Books.
- Urry, J. (2005) The Place of Emotions within Place. In: Davidson, J., Bondi, L. & Smith, M. (eds.) *Emotional Geographies*. Aldershot: Ashgate.
- Vanderbilt, T. (2002) *Survival City: Adventures among the Ruins of Atomic America*, New York, New York, Princeton Architectural Press.
- Vaneigem, R. (2010) *The Revolution of Everyday Life*, Wellington, New Zealand, Rebel Press.
- Veitch, J. (2010) Dr. Strangelove's Cabinet of Wonder: Sifting through the Atomic Ruins at the Nevada Test Site. In: Hell, J. & Schönle, A. (eds.) *Ruins of Modernity*. London: Duke University Press.
- Vidler, A. (1990) Case Per Cyborg: Protesti Domestiche Da Salvador Dali a Diller E Scofidio [Homes for Cyborgs: Domestic Prostheses from Salvador Dali to Diller and Scofidio]. *Ottagono*, 96, 36-55.
- Waite, G. & Cook, L. (2007) Leaving Nothing but Ripples on the Water: Performing Ecotourism Natures. *Social & Cultural Geography*, 8, 535-550.
- Wasik, B. (2006) My Crowd: Or, Phase 5. *Harper's Magazine*. New York: The Harper's Magazine Foundation.
- Weber, E. (2009) *The Solitary Life of Cranes*. United Kingdom: Channel 4.
- Weisman, A. (2007) *The World without Us*, New York, NY, Thomas Dunne Books.
- Weiss, G. (1999) *Body Images : Embodiment as Intercorporeality*, New York, Routledge.
- Wershler-Henry, D. (2005) Urban Life: Usufruct in the City. *Globe and Mail*, 12/31/05.
- Western, J. (1997) *Outcast Cape Town*, Los Angeles, California, University of California Press.
- Whatmore, S. (2002) *Hybrid Geographies: Natures, Cultures, Spaces*, Thousand Oaks, California, SAGE.

- Whipplesnaith (2007) *The Night Climbers of Cambridge*, Cambridge, United Kingdom, Oleander Press.
- White, S. A. (2003) *Participatory Video: Images That Transform and Empower*, London, Sage Publications.
- Wilde, O. (1998) *Collected Works of Oscar Wilde*, Hertfordshire, Wordsworth Editions Ltd.
- Williams, R. H. (1990) *Notes on the Underground: An Essay on Technology, Society and the Imagination*, Cambridge, MA, MIT Press.
- Willis, P. & Jefferson, T. (1990) The Cultural Meaning of Drug Use. In: Hall, S. (ed.) *Resistance through Rituals: Youth Subcultures in Post-War Britain*. London: Routledge.
- Wilson, R. N. (1981) The Courage to Be Leisured. *Social Forces*, 60, 208-303.
- Witmore, C. L. (2005) Four Archaeological Engagements with Place: Mediating Bodily Experience through Peripatetic Video. *Visual Anthropology Review*, 20, 51-71.
- Worth, S. (1981) *Studying Visual Communication: Selected Writings*, Philadelphia, University of Pennsylvania Press.
- Worth, S. & Adair, J. (1972) *Through Navajo Eyes; an Exploration in Film Communication and Anthropology* Bloomington, Indiana, Indiana University Press.
- Wright, R. B. (2008) *Dreams and Shadows: The Future of the Middle East*, New York, New York, Penguin.
- Wylie, J. (2005) A Single Day's Walking: Narrating Self and Landscape on the South West Coast Path. *Transactions of the Institute of British Geographers*, 30, 234-247.
- Wylie, J. (2007) The Spectral Geographies of W.G. Sebald. *Cultural Geographies*, 14, 171-188.
- Wylie, J. (2009) Landscape, Absence and the Geographies of Love. *Transactions of the Institute of British Geographers*, 34, 275-289.
- Youngs, M. J. (1980) *Cultural Geography: And Introduction and Guide to the Use of Films in Research*, London, The London School of Economics and Political Science, Graduate School of Geography.
- Zero (2009) The Anger Tunnel. *Drainor Magazine*. London, United Kingdom.
- Zylinska, J. (2009) *Bioethics in the Age of New Media*, Cambridge, MIT Press.

### Appendix A – Snowball sample spreadsheet

This chart is not an exhaustive list of people I have met on this project. I have chosen to include only people who I have explored with and who have contributed thoughts, comments or actions to this work.

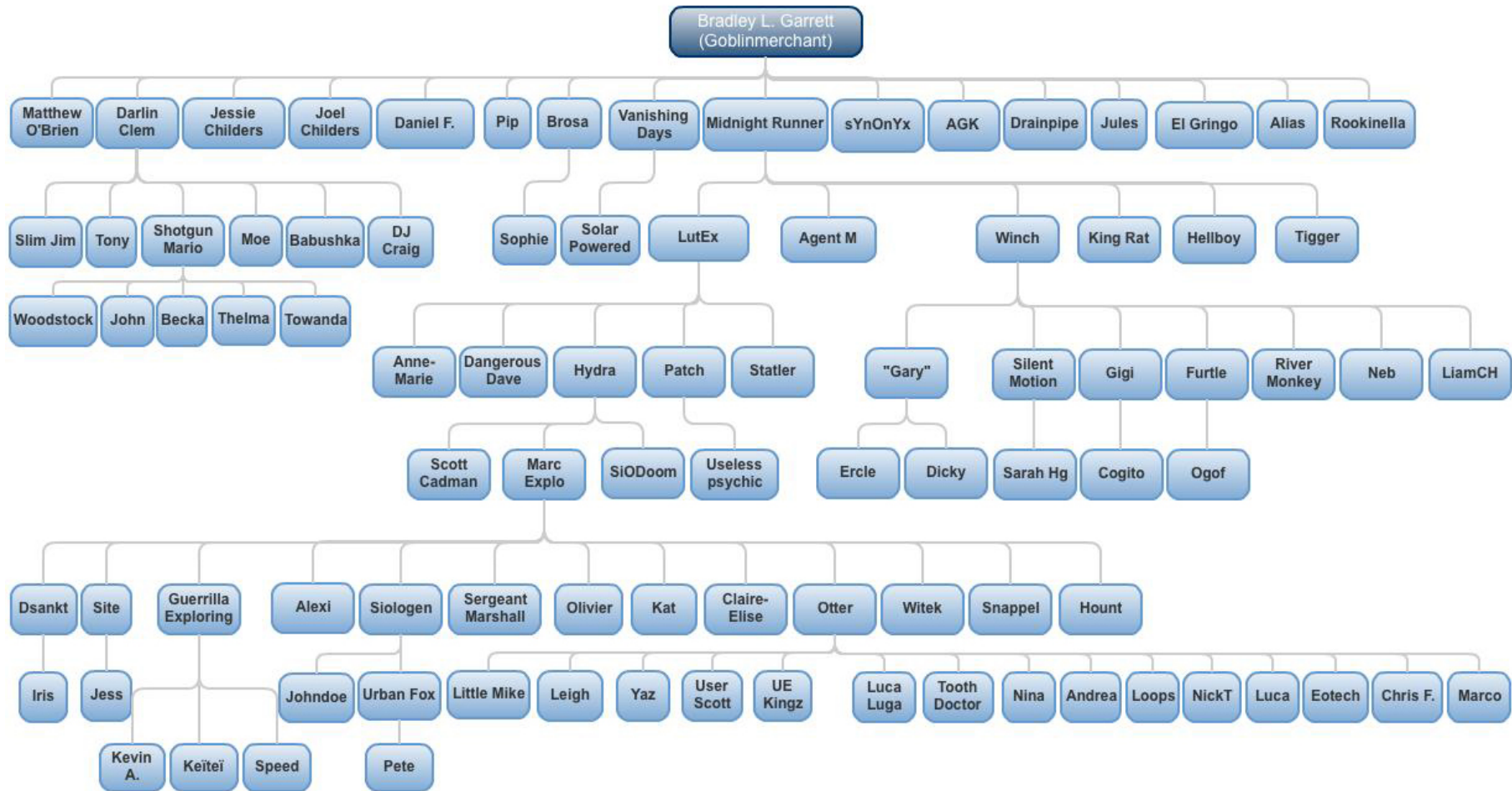

### Appendix B – Exploration fieldwork database

This list of locations explored, as with the sampling chart, is not exhaustive. Some sites have been excluded due to their sensitive nature or at the request of project participants. Other locations have been listed in vague terms for similar reasons.

Site	Site Name	Date	Location	Crew
1	Grain Fort	January 2009	Gillingham, Kent, UK	Vanishing Days, Solar Powered
2	Gun emplacements	January 2009	Gillingham, Kent, UK	Vanishing Days, Solar Powered
3	Bastion	January 2009	Dover, Kent, UK	Vanishing Days, Solar Powered
4	Mathew's Equestrain Centre	January 2009	Gillingham, Kent, UK	Vanishing Days, Solar Powered
5	West Park Asylum	January 2009	Epsom, Surrey, UK	Midnight Runner, Agent M, LutEx
6	St. Ebbas Asylum	January 2009	Epsom, Surrey, UK	Midnight Runner, Agent M, LutEx, King Rat, Winch, Hellboy
7	Wandsworth Kops Brewery	February 2009	Fulham, London, UK	Alone
8	The Golden Hinde	March 2009	London Bridge, UK	Hydra, LutEx
9	Luton WWII Bunkers	March 2009	Luton, UK	LutEx, Hydra
10	Calico Borax Mines	March 2009	Calico, California, USA	Pip
11	Rock-a-hoola Water Park	April 2009	Yermo, California, USA	sYnoNyx
12	The Mission Inn	April 2009	Riverside, California, USA	Daniel F.
13	Severalls Asylum	April 2009	Colchester, UK	Patch, Dangerous Dave, Statler, LutEx
14	Zed Rocket	May 2009	Dover, UK	Vanishing Days, Solar Powered
15	The Bastion	May 2009	Dover, UK	Vanishing Days, Solar Powered
16	Bastion side tunnels	May 2009	Dover, UK	Vanishing Days, Solar Powered
17	Shorts Tunnels	May 2009	Dover, UK	Vanishing Days, Solar Powered
18	Battersea Power Station	May 2009	Battersea, London, UK	Hydra
19	Black Widow Russian Submarine	June 2009	Rochester, UK	Hydra
20	Camden Catacombs	June 2009	Camden, London, UK	Hydra
21	Paris Catacombs	July 2009	Paris, France	Hydra, Marc Explo
22	Zepplin Hanger	July 2009	Paris, France	Hydra, Marc Explo, Olivier, Kat
23	Military Training Fortress	July 2009	Paris, France	Hydra, Marc Explo, Olivier, Kat
24	Royal Holloway Steam Tunnels	September 2009	Egham, Surrey, UK	Marc Explo
25	West Park Asylum	September 2009	Epsom, Surrey, UK	Marc Explo
26	The Great Shaft	October 2009	Dover, UK	Marc, Hount
27	The Bastion	October 2009	Dover, UK	LutEx, Hydra, Vanishing Days
28	Bastion side bunkers	October 2009	Dover, UK	LutEx, Hydra, Vanishing Days
29	Zed Rocket	October 2009	Dover, UK	LutEx, Hydra, Vanishing Days
30	Old Street Construction Site	October 2009	London	Helen

Site	Site Name	Date	Location	Crew
31	Cane Hill Asylum	October 2009	Coulsdon, UK	Winch
32	Mesen Castle	October 2009	Belgium	Furtle, River Monkey, Tigger, Winch, Statler
33	Bloso Hofstade	October 2009	Belgium	Furtle, River Monkey, Tigger, Winch, Statler
34	Stella Artois Brewery	October 2009	Belgium	Furtle, River Monkey, Tigger, Winch, Statler
35	Salve Mater Sanitorium	October 2009	Belgium	Furtle, River Monkey, Tigger, Winch, Statler
36	Chateau de Noisy	October 2009	Belgium	Furtle, River Monkey, Tigger, Winch, Statler
37	Asylum	October 2009	Belgium	Furtle, River Monkey, Tigger, Winch, Statler
38	Val St Lambert	October 2009	Belgium	Furtle, River Monkey, Tigger, Winch, Statler
39	The Horror Lab	October 2009	Belgium	Furtle, River Monkey, Tigger, Winch, Statler
40	Shorts tunnels	October 2009	Dover, UK	Marc Explo, Vanishing Days, Solar Powered
41	Lillesden Estate Mansion	October 2009	Hawkhurst, Kent, UK	Marc Explo, Vanishing Days
42	Abandoned School	October 2009	Kent, UK	Marc Explo, Vanishing Days
43	Pyestock National Gas Turbine Establishment	October 2009	Farnborough, UK	Marc Explo
44	Clapham North Bunker	November 2009	Clapham, London, UK	LutEx, Anne-Marie, Marc, Jules, Hydra
45	Kosmos Hotel	December 2009	Belgium	Silent Motion, Statler, Winch
46	Home RTT Oostdunkirke	December 2009	Belgium	Silent Motion, Statler, Winch
47	Zweveyem Power Station Transfo	December 2009	Belgium	Silent Motion, Statler, Winch
48	Varia Cinema	December 2009	Belgium	Silent Motion, Statler, Winch
49	Fort De La Chartreuse	December 2009	Belgium	Silent Motion, Statler, Winch
50	Montzen Gare	December 2009	Belgium	Silent Motion, Statler, Winch
51	St Josefsheim Missionary	December 2009	Germany	Silent Motion, Statler, Winch
52	Sinteranlage	December 2009	Germany	Silent Motion, Statler, Winch
53	Kokerie Zollverein	December 2009	Germany	Silent Motion, Statler, Winch
54	Beelitz	December 2009	Germany	Silent Motion, Statler, Winch
55	Lungenheilstätte am Grabowsee	December 2009	Germany	Silent Motion, Statler, Winch
56	Buchallee Weißensee Sauglings und Kinder Krankenhaus	December 2009	Berlin, Germany	Silent Motion, Statler, Winch
57	Großen runden raum zug plattenspieler	December 2009	Berlin, Germany	Silent Motion, Statler, Winch
58	Vogelsang Soviet Military Base	December 2009	Havel, Germany	Silent Motion, Statler, Winch
59	World Fair 2000 Dutch Pavillion	December 2009	Hanover, Germany	Silent Motion, Statler, Winch
60	Textilfabrik NTS	December 2009	Germany	Silent Motion, Statler, Winch
61	Wageningse Berg	December 2009	Netherlands	Silent Motion, Statler, Winch
62	Battersea Power Station	December 2009	Wandsworth, London, UK	Winch, "Gary", Silent Motion, Hydra, Ercle, Statler

Site	Site Name	Date	Location	Crew
63	Gillette Factory	January 2010	Hounslow, London	Silent Motion, Hydra, "Gary"
64	Battersea Power Station	January 2010	Wandsworth, London, UK	Silent Motion, Hydra
65	Springfield Hospital	January 2010	Tooting, London, UK	Silent Motion
66	St. Mary's roof	January 2010	Clapham, London, UK	Alone
67	St. Josephs Missionary	January 2010	Mill Hill, London, UK	"Gary", Hydra
68	Temple Court	January 2010	City of London, UK	"Gary", Hydra, LutEx, Tigger, Patch, Vanishing Days, Neb
69	New Court	February 2010	City of London, UK	"Gary", Gigi, Winch
70	Paris Catacombs	February 2010	Paris, France	Marc, Statler, LutEx, Silent Motion
71	Montrouge Tower	February 2010	Paris, France	Marc, Statler, Winch LutEx, Silent Motion
72	Paris Underground Cinema	February 2010	Paris, France	Marc, Statler, Witek, Winch, LutEx, Silent Motion, Kat, Olivier
73	Wolfsschlucht II	February 2010	North of Paris, France	Marc, Winch, Statler, Silent Motion
74	NATO Command Bunker	February 2010	Paris, France	Marc, Winch, Statler, Silent Motion
75	Roosevelt Island F Train Metro Tunnel	March 2010	New York City, USA	Alone
76	New York City Hotel Rooftop Near ESB	March 2010	New York City, USA	Ellie Miles
77	Boron Federal Prison Camp	April 2010	Boron, California, USA	Alone
78	March Air Reserve Base Abandoned Hospital	April 2010	Riverside, California, USA	Pip et al
79	LA County Courthouse	April 2010	Riverside, California, USA	Joel and Jesse Childers
80	Linda Vista Hospital	April 2010	Riverside, California, USA	Joel and Jesse Childers
81	BF Cable Runs	May 2010	London, UK	"Gary", hydra
82	Westbourne Sewer	May 2010	London, UK	Marc, Statler, Winch
83	Brixton Ruin	May 2010	South London, UK	Anja
84	River Lea Ruin	May 2010	London, UK	Dave
85	Temple Court	June 2010	London, UK	Alone
86	New Cavendish House	June 2010	London, UK	Silent Motion
87	Westbourne Sewer	June 2010	London, UK	Winch, Silent Motion, Statler
88	Medieval Castle wall	July 2010	Budapest	Alone
89	West Ham Storm Relief	July 2010	East London	Silent Motion, Statler, Tigger
90	Reading Rope Play / Mecca Bingo	July 2010	Reading, UK	Neb, Patch, Statler, "Gary", Silent Motion, Winch, Erika
91	Bastion	July 2010	UK	"Gary", Winch, Statler
92	Zed Rocket	July 2010	UK	"Gary", Winch, Statler
93	St. Margaret Bunker	July 2010	UK	"Gary", Winch, Statler
94	Palais de Justice	July 2010	Belgium	"Gary", Winch, Statler
95	Train Depot	July 2010	Belgium	"Gary", Winch, Statler

Site	Site Name	Date	Location	Crew
96	Cokerie d'Aderleus	July 2010	Belgium	"Gary", Winch, Statler
97	Charleroi Metro	July 2010	Belgium	"Gary", Winch, Statler
98	Chateau Noisy	July 2010	Belgium	"Gary", Winch, Statler
99	Central Thermique	July 2010	Luxembourg	"Gary", Winch, Statler
100	Terre Rouge	July 2010	Luxembourg	"Gary", Winch, Statler
101	Belval Blast Furnace	July 2010	Luxembourg	"Gary", Winch, Statler
102	Liege Blast Furnace	July 2010	Belgium	"Gary", Winch, Statler
103	University of Liege	July 2010	Belgium	"Gary", Winch, Statler
104	Stradtbad Duisberg	July 2010	Germany	"Gary", Winch, Statler
105	Landschaftepark Duisberg Nord	July 2010	Germany	"Gary", Winch, Statler
106	Zeche Hugo	July 2010	Germany	"Gary", Winch, Statler
107	Gotha Base	July 2010	Germany	"Gary", Winch, Statler
108	Krankenhaus Gotha	July 2010	Germany	"Gary", Winch, Statler
109	Nohra Base	July 2010	Germany	"Gary", Winch, Statler
110	Gera-Milbitz Hospital	July 2010	Germany	"Gary", Winch, Statler
111	Jena Base	July 2010	Germany	"Gary", Winch, Statler
112	Grossenheim (MIG)	July 2010	Germany	"Gary", Winch, Statler
113	Kraftwerk Plessa	July 2010	Germany	"Gary", Winch, Statler
114	Szpratowa Base Selvain	July 2010	Poland	"Gary", Winch, Statler
115	Keznya Lesna	July 2010	Poland	"Gary", Winch, Statler
116	Klomino/ Grodek	July 2010	Poland	"Gary", Winch, Statler
117	Borne Sulinowo	July 2010	Poland	"Gary", Winch, Statler
118	Kluczewo	July 2010	Poland	"Gary", Winch, Statler
119	Ravensbruck	July 2010	Germany	"Gary", Winch, Statler
120	Estate thing	July 2010	Germany	"Gary", Winch, Statler
121	Havel/Vogelsang	July 2010	Germany	"Gary", Winch, Statler
122	Eberswald papermill	July 2010	Germany	"Gary", Winch, Statler
123	Karlshorst KGB Headquarters	July 2010	Germany	"Gary", Winch, Statler
124	Falkenhagen	July 2010	Germany	"Gary", Winch, Statler
125	Barenquell Brewery	July 2010	Germany	"Gary", Winch, Statler
126	Olympisches Dorf	July 2010	Germany	"Gary", Winch, Statler
127	Kaserne Krampnitz	July 2010	Germany	"Gary", Winch, Statler
128	Kraftwerk Vockerode	July 2010	Germany	"Gary", Winch, Statler
129	Schwermaschinenbau	July 2010	Germany	"Gary", Winch, Statler
130	Marienborn DDR Border Crossing	July 2010	Germany	"Gary", Winch, Statler

Site	Site Name	Date	Location	Crew
131	HH3 Hospital	July 2010	Germany	"Gary", Winch, Statler
132	2000 Expo	July 2010	Germany	"Gary", Winch, Statler
133	Headstocks	July 2010	Germany	"Gary", Winch, Statler
134	Pre Metro	July 2010	Antwerp, Belgium	"Gary", Winch, Statler
135	HDR Hospital	July 2010	Belgium	"Gary", Winch, Statler
136	Mark Lane disused station	August 2010	London, UK	Tigger, Winch, Statler
137	Eagle House	August 2010	London, UK	Neb, Winch, Statler
138	Battersea Power Station (by boat)	August 2010	London, UK	Statler, LutEx, Patch
139	Rosebury Cable Runs	August 2010	London, UK	"Gary", Statler
140	Kingsway Tram Tunnel	August 2010	London, UK	Winch, Silent Motion, Statler
141	Cathedrale Saint Pierre	September 2010	Beauvais, France	Marc, Claire-Elise
142	FD Roosevelt Metro Station	September 2010	Paris, France	Marc
143	Metro Workshop	September 2010	Paris, France	Marc
144	Metro Bridge	September 2010	Paris, France	Marc
145	Croix Rouge	September 2010	Paris, France	Marc
146	St. Sulpice Cathedral	September 2010	Paris, France	Marc
147	EDF Tunnels	September 2010	Paris, France	Marc
148	Shoreditch Church	September 2010	London, UK	Katherine
149	Embankment Runs	September 2010	London, UK	User_Scott, Snappel, Silent Motion, Marc
150	Embankment Runs	September 2010	London, UK	Marc, "Gary"
151	St. Clements Hospital	September 2010	East London, UK	Neb, Marc, "Gary"
152	Ravenscourt Hospital	September 2010	London, UK	Neb, Marc, Winch, "Gary"
153	Lantern Court	September 2010	London, UK	Otter, Marc
154	Burlington	September 2010	London, UK	Hydra, Neb, Brickman, Statler, Silent Motion, Patch
155	Rubix Drain Junction	October 2010	London, UK	Silent Motion, Statler
156	River Fleet	October 2010	London, UK	Winch, Neb
157	Lord's Disused Tube Station	October 2010	London, UK	Otter, Marc, Neb, Winch
158	Lucky Charms Drain Junction	October 2010	London, UK	Yaz, Otter
159	King's Reach tower (Marc Explo's bday)	October 2010	London, UK	Hydra, LutEx, "Gary", Patch, Silent Motion
160	Millennium Mills	November 2010	London, UK	"Gary"
161	Highbury & Islington	November 2010	London, UK	Alone
162	Battersea Power Station (Bonfire Night)	November 2010	London, UK	Neb, Silent Motion, Hydra, Erclé,
163	King's Reach Tower	November 2010	London, UK	Siologen, Patch, "Gary", Silent Motion, Marc, Otter, El Gringo, Speed,



Site	Site Name	Date	Location	Crew
				Guerrilla Exploring, Yaz, Loops, Sophie, Luke, Brosa, Sergeant Marshall, Claire-Elise, Cogito, Sean, Rupert
164	Castle Wall	November 2010	Istanbul, Turkey	Alone
165	Jute Ruin	November 2010	Dundee, Scotland	Brosa, J Prior, Ines A.
166	Burton Brewed Bitter	December 2010	East London, UK	Silent Motion
167	Abbey Mills Pumping Station	December 2010	East London, UK	Silent Motion, Brosa, Sophie, Sarah Hg, Maria
168	Lockheed Martin Rocket Testing Facility	December 2010	Lake Elsinore, California, USA	Alone
169	Barstow Dead Mall	December 2010	Barstow, California, USA	Alone
170	International Drain Meet 2011	January 2011	London, UK	Site, Jess, Otter, Luca, Marc Explo, Witek, Siologen, Leigh, User Scott, Eotech, John Doe, Yaz, NickT, Frainy, Neb, Tooth Doctor, Silent Motion, Mike Rippon, Statler, Winch, Marco, Luca, UE Kingz, Vivo, Pete, Andrea, Urban Fox, Joseph Bazallgete
171	Westbourne (filming with Otter)	January 2011	London, UK	Site, Jes, Otter
172	Paris Crane	January 2011	Paris, France	Winch, Marc, Otter
173	Metro line 4 extension	January 2011	Montrouge, France	Winch, Marc, Otter
174	RER "A" and "D"	January 2011	Paris, France	Winch, Marc, Otter, Dsankt
175	Arsenal Station	January 2011	Paris, France	Winch, Marc, Otter, Dsankt, Iris, Kat, Olivier
176	Paris water supply to bridge	January 2011	Paris, France	Winch, Marc, Otter
177	Paris Sewers (Nadar's Dungeon)	January 2011	Paris, France	Winch, Marc, Otter
178	The Shard	January 2011	London, UK	Marc, "Gary"
179	Lucky Charms Drain	February 2011	London, UK	Patch, Otter, Marc, Silent Motion, Statler
180	Down Street disused Tube station	February 2011	London, UK	Siologen, Statler, Neb, Winch
181	Secure File Storage	*****	South London, UK	Statler, "Gary", Otter, Marc Explo, Silent Motion, Patch
182	Kops Brewery	February 2011	Wandsworth, UK	Drainpipe, Andy, Nida
183	Aldgate East Crane	February 2011	London, UK	Alone
184	Clapham North Bunker Party	February 2011	South London, UK	LiamCH, Siologen, Gigi, Drainpipe, Alias, Cogito, Guerrilla Exploring, Winch, Statler, Silent Motion, Neb, LutEx, Urban Fox, El Gringo, Loops, the Badman, NickT, Matt Wootton, Jess, Site, Otter.

1<sup>st</sup> March 2011 marks the end of my "fieldwork period". Though no locations after this date are included, the total list of locations explored over the course of the entire PhD is around 220.

### Appendix C - Exploration location maps



